



I.Mak®
REDÜKTÖR & VARYATÖR A.Ş.

Ağır Hizmet Tipi Redüktörler

Horizontal Helical Gear Unit
Motoréducteurs hélicoïdaux à usage industriel

A02



SERIES
A

2022
TR | EN | FR

Gearboxes and Drives / Moto Réducteurs

	Tip Tanımları	Type Designations	Typenbezeichnungen
A / 2A / 3A / 4A ...	Ağır Hizmet Tipi, Helisel Dişlili Motorsuz Redüktör	Horizontal Type Helical Geared Units	<i>Stirnradgetriebe, Horizontal Typ</i>
2AE / 3AE ...	Ağır Hizmet Extruder Tip, Helisel Dişlili Motorsuz Redüktör	Horizontal Type Helical Geared Units, Extruder Type	<i>Stirnradgetriebe, Horizontal-Extruder Typ</i>
İRSAM ...	Ayaklı, Sonsuz Vidalı Motorlu Redüktör	Worm Geared Motors, Foot Mounted	<i>Schneckengetriebemotoren, Fußausführung</i>
İRSFM ...	Flanşlı, Sonsuz Vidalı Motorlu Redüktör	Worm Geared Motors, Flange Mounted	<i>Schneckengetriebemotoren, Flanschausführung</i>
İRSA ...	Ayaklı, Sonsuz Vidalı Motorsuz Redüktör	Worm Geared Units, Foot Mounted	<i>Schneckengetriebe, Fußausführung</i>
İRSF ...	Flanşlı, Sonsuz Vidalı Motorsuz Redüktör	Worm Gear Units, Foot Mounted	<i>Schneckengetriebe, Flanschausführung</i>
İRSAP ... (IEC)	Ayaklı, Sonsuz Vidalı, Pam Flanşlı (IEC), Motorsuz Redüktör	Worm Geared Units, Foot Mounted, with IEC Flange	<i>Schneckengetriebe, Fußausführung, IEC Flansch</i>
İRSFP ... (IEC)	Flanşlı, Sonsuz Vidalı, Pam Flanşlı (IEC), Motorsuz Redüktör	Worm Gear Units, Foot Mounted, with IEC Flange	<i>Schneckengetriebe, Flanschausführung, IEC Flansch</i>
İRSDM ...	Ayaklı, Sonsuz Vidalı, Helisel Dişlili Motorlu Redüktör	Helical-Worm Geared Motors, Foot Mounted	<i>Stirnrad-Schneckengetriebemotoren, Fußausführung</i>
İRSDFM ...	Flanşlı, Sonsuz Vidalı, Helisel Dişlili Motorlu Redüktör	Helical-Worm Geared Motors, Flange Mounted	<i>Stirnrad-Schneckengetriebemotoren, Flanschausführung</i>
İRSD ...	Ayaklı, Sonsuz Vidalı, Helisel Dişlili Motorsuz Redüktör	Helical-Worm Gear Units, Foot Mounted	<i>Stirnrad-Schneckengetriebe, Fußausführung</i>
İRSDF ...	Flanşlı, Sonsuz Vidalı, Helisel Dişlili Motorsuz Redüktör	Helical-Worm Gear Units, Flange Mounted	<i>Stirnrad-Schneckengetriebe, Flanschausführung</i>

Redüktörlerin Çıkış Momentleri ve Makinayı Çalıştırmak için Gerekli Güç Hesabı

Genel olarak redüktör kataloglarındaki çıkış milindeki momentler tablo halinde verilir.

Redüktör çıkış milindeki moment aşağıdaki gibi hesaplanabilir:

$$M_2 = 9550 \frac{P \cdot \eta}{n_2} \dots (1)$$

M_2 = Döndürme Momenti (Nm)

N = Motor Gücü (kW)

η = Redüktör Verimi

n_2 = Redüktör Çıkış Devri

Örnek 1:

1,5 kW gücünde bir elektrik motoru direkt akuple edilmiş, çıkış 30 d/d ve verimi %94 olan redüktörün çıkış milinden moment formül (1)'den

$$M_2 = 9550 \cdot 1,5 \cdot 0,94 / 30$$

$$M_2 = 448 \text{ Nm}$$

Örnek 2:

G= 700 kg ağırlığındaki bir yük, $\alpha = 20^\circ$ eğik duran bir konveyör üzerinden bir kamyonu yükleme yapmaktadır. Bantın hızı $v = 0,4$ m/sn olduğuna göre bu yükü taşımak için kaç kW gücünde motor-redüktör grubuna ihtiyaç vardır? Konveyörün verimi $\eta_k = 0,85$ ve redüktörün verimini $\eta_r = 0,94$ olduğunu kabul edersek problemin çözümü için;

$$P(kW) = \frac{(1/8 \cdot \cos \alpha + \sin \alpha) \cdot G(kg) \cdot v(m/sn)}{102 \cdot \eta_r \cdot \eta_k} \dots (2)$$

formülü kullanılır.

Burada belirtilmesi gereken önemli bir nokta, sistemin rulmanlı yataklarla yataklanmış olmasıdır. Bu durumda formüldeki 1/8 değerini kullanabiliriz. Eğer yük sürtünmeli taşınsaydı, 1/8 değeri yerine sürtünme katsayısı bilinmesi gereken değeri kullanılmalı ve 1/8 yerine bu değer alınmalıdır.

Sürtünmesiz kabul edilebilecek şartlardaki kuvvet ihtiyacı, açıya göre hiçbir zaman G değerinin üstüne çıkamaz.

$$P_h = \frac{(1/8 \cdot \cos 20^\circ + \sin 20^\circ) \cdot 700 \cdot 0,4}{102 \cdot 0,94 \cdot 0,85} = 1,57 \text{ kW}$$

$$P = 1,15 \cdot P_h = 1,15 \cdot 1,57 = 1,80 \text{ kW}$$

Standart motor gücünü seçersek 2,2 kW alınır.

Calculation of Gearbox Output Torque and Required Power to Operate Machine

Output torques of gearbox are generally given as table in the catalogues.

Torque of gearbox output shaft should be calculated as follows:

$$M_2 = 9550 \frac{P \cdot \eta}{n_2} \dots (1)$$

M_2 = Output Torque (Nm)

N = Motor Power (kW)

η = Gearbox Efficiency

n_2 = Gearbox Output Speed

Example 1:

A 1,5 kW electric motor is directly coupled to a gearbox, output speed is 30 r.p.m and gearbox efficiency is 94% from the equation (1)

$$M_2 = 9550 \cdot 1,5 \cdot 0,94 / 30$$

$$M_2 = 448 \text{ Nm}$$

Example 2:

G=700 kg load are to be carried on a conveyor belt, that is inclined at $\alpha = 20^\circ$ from the horizontal, to a lorry. Conveyor speed is $v = 0,4$ m/sec. What is the required power of geared motor? Belt Conveyor efficiency is $\eta_k = 0,85$ and gearbox efficiency is $\eta_r = 0,94$

$$P(kW) = \frac{(1/8 \cdot \cos \alpha + \sin \alpha) \cdot G(kg) \cdot v(m/sn)}{102 \cdot \eta_r \cdot \eta_k} \dots (2)$$

Equation(2) is used for the solution of the problem. It is important to mention that belt conveyor system is working on the ball bearings. If the load is carried without using bearings, that is sliding under friction, real friction coefficient must be used instead of 1/8 value.

Power requirement for frictionless conditions, never exceeds G value according to angle. When the values are put in their places in the equation (2).

$$P_h = \frac{(1/8 \cdot \cos 20^\circ + \sin 20^\circ) \cdot 700 \cdot 0,4}{102 \cdot 0,94 \cdot 0,85} = 1,57 \text{ kW}$$

$$P = 1,15 \cdot P_h = 1,15 \cdot 1,57 = 1,80 \text{ kW}$$

Standard motor power of 2 kW should be taken.

Die Berechnung Der Abtriebsdrehmomente Des Getriebemotors und Die Berechnung Der Leistung, Die für Den Betrieb Des Motors Nötig Ist.

Im Allgemeinen werden die Abtriebsdrehmomente des Getriebemotors im Motorkatalog tabellarisch aufgezeigt.

Der Moment der Getriebemotor Abtriebswelle wird wie folgt berechnet:

$$M_2 = 9550 \frac{P \cdot \eta}{n_2} \dots (1)$$

M_2 = Drehmoment (Nm)

N = Motorleistung (kW)

η = Effizienz des Getriebemotors

n_2 = Abtriebsdrehzahl des Getriebemotors

Beispiel 1:

Ein Elektromotor mit 1,5 kW Leistung ist direkt gekoppelt. Der Abtriebsdrehmoment des Getriebemotors, dessen Abtriebsdrehzahl 30 U/min. und Effizienz 94% beträgt, wird nach der Formel (1) wie folgt berechnet:

$$M_2 = 9550 \cdot 1,5 \cdot 0,94 / 30$$

$$M_2 = 448 \text{ Nm}$$

Beispiel 2:

Eine Ladung mit einem Gewicht von G= 700 kg wird durch ein Förderband mit einer Neigung von $\alpha = 20^\circ$ in einen Lastwagen geladen. Wie groß ist die benötigte Leistung der Getriebemotorgruppe, wenn die Geschwindigkeit des Förderbandes $v = 0,4$ m/s beträgt? Wenn davon ausgegangen wird, dass die Leistung des Förderbandes $\eta_k = 0,85$ und die Leistung des Getriebemotors $\eta_r = 0,94$ beträgt, wird für die Lösung dieser Frage folgende Formel angewendet:

$$P(kW) = \frac{(1/8 \cdot \cos \alpha + \sin \alpha) \cdot G(kg) \cdot v(m/sn)}{102 \cdot \eta_r \cdot \eta_k} \dots (2)$$

Der wichtigste Punkt, der hierzu angegeben werden muss, ist, dass das System mit Kugellagern eingebettet ist. In diesem Fall können wir den Wert 1/8 in der Formel anwenden. Falls die Ladung nicht mit Kugellagern sondern Gleitlagern befördert wäre, sollte anstelle des Wertes 1/8 der Wert mit Reibungskoeffizient angewendet werden

Örnek 3:

Konveyör yere tam paralel taşınıyorsa, bu durumda $\alpha = 0^\circ$ olacağından formül (2)'den;

$$P_h = \frac{(1/8) \cdot 700 \cdot 0,4}{102 \cdot 0,94 \cdot 0,85} = 0,43 \text{ kW}$$

$$P = 1,15 \cdot P_h = 1,15 \cdot 0,43 = 0,49 \text{ kW}$$

Standart motor gücünü seçersek 0,55 kW alınır.

Örnek 4:

Yük Asansörde dik olarak taşınıyorsa, bu durumda $\alpha = 90^\circ$ olacağından formül (2)'den;

$$P_h = \frac{700 \cdot 0,4}{102 \cdot 0,94 \cdot 0,85} = 3,43 \text{ kW}$$

$$P = 1,15 \cdot P_h = 1,15 \cdot 3,43 = 3,95 \text{ kW}$$

Standart motor gücünü seçersek 4 kW alınır.

Redüktör Devir Sayısının Hesabı

Redüktör devir sayısının bulunabilmesi için konveyörün redüktör tarafından çevrilen tamburun veya asansör halat tamburunun çapı bilinmelidir. Bu takdirde aşağıdaki formül yardımıyla redüktör devir sayısı hesap edilebilir.

$$n_2(d/d) = \frac{V(m/sn) \cdot 6 \cdot 10^4}{d_1(mm) \cdot \pi} = \dots(3)$$

V = Bant veya Halatın hızı (m/sn)
d₁ = Tamburun Çapı (mm)
Mesela sistemdeki Bantın hızı 0,4 m/sn ve tamburun çapı Ø200 mm olsaydı redüktör devri: Formül (3)'ten.

$$n_2(d/d) = \frac{0,4 \cdot 6 \cdot 10^4}{200 \cdot \pi} = 38,2 d/d$$

Example 3:

The conveyor is at horizontal position. In this case $\alpha = 0^\circ$ From the equation (2)

$$P_h = \frac{(1/8) \cdot 700 \cdot 0,4}{102 \cdot 0,94 \cdot 0,85} = 0,43 \text{ kW}$$

$$P = 1,15 \cdot P_h = 1,15 \cdot 0,43 = 0,49 \text{ kW}$$

Standard motor power of 0,55 kW should be taken.

Example 4:

If the load carried at a vertical position $\alpha = 90^\circ$ From the equation (2)

$$P_h = \frac{700 \cdot 0,4}{102 \cdot 0,94 \cdot 0,85} = 3,43 \text{ kW}$$

$$P = 1,15 \cdot P_h = 1,15 \cdot 3,43 = 3,95 \text{ kW}$$

Standard motor power of 4 kW should be taken.

Calculation of Gearbox Speed

To be able to calculate gearbox output speed, head pulley diameter of conveyor or lift must be known. In this case, gearbox output speed is calculated by the following equation:

$$n_2(d/d) = \frac{V(m/sec) \cdot 6 \cdot 10^4}{d_1(mm) \cdot \pi} = \dots(3)$$

V = Conveyor Belt or Rope Speed(m/sec)
d₁ = Head Pulley Diameter (mm)

For instance, conveyor belt speed is 0,4 m/sec head pulley diameter is 200 mm Gearbox output speed is:

$$n_2(r.p.m) = \frac{0,4 \cdot 6 \cdot 10^4}{200 \cdot \pi} = 38,2 r.p.m$$

Die benötigte Leistung unter reibungslosen Konditionen, übersteigt entsprechend des Winkels niemals den Wert G. Wenn nun die Angaben in die Formel eingesetzt werden:

$$P_h = \frac{(1/8 \cdot \cos 20^\circ + \sin 20^\circ) \cdot 700 \cdot 0,4}{102 \cdot 0,94 \cdot 0,85} = 1,57 \text{ kW}$$

$$P = 1,15 \cdot P_h = 1,15 \cdot 1,57 = 1,80 \text{ kW}$$

Falls eine Standart Motorleistung gewählt wird, wird 2,2 kW eingesetzt.

Beispiel 3:

Das Förderband ist horizontal positioniert. In diesem Fall ist $\alpha = 0^\circ$ Aus Lösungsformel (2):

$$P_h = \frac{(1/8) \cdot 700 \cdot 0,4}{102 \cdot 0,94 \cdot 0,85} = 0,43 \text{ kW}$$

$$P = 1,15 \cdot P_h = 1,15 \cdot 0,43 = 0,49 \text{ kW}$$

Falls eine Standart Motorleistung gewählt wird, wird 0,55 kW eingesetzt.

Beispiel 4:

Falls die Ladung vertikal mit einem Aufzug getragen worden wäre in diesem Fall beträgt $\alpha = 90^\circ$, wird die Berechnung mit der Formel (2) wie folgt vorgenommen.

$$P_h = \frac{700 \cdot 0,4}{102 \cdot 0,94 \cdot 0,85} = 3,43 \text{ kW}$$

$$P = 1,15 \cdot P_h = 1,15 \cdot 3,43 = 3,95 \text{ kW}$$

Falls eine Standart Motorleistung gewählt wird, wird 4 kW eingesetzt.

Berechnung Der Getriebemotor - Abtriebsdrehzahl

Damit die Getriebemotor-Abtriebsdrehzahl berechnet werden kann, muss der Durchschnitt der Umleitrolle des Förderbands bzw. Aufzugseils, das vom Getriebemotor gedreht wird, bekannt sein. In diesem Fall, kann mit Hilfe der folgenden Formel die Getriebemotor-Abtriebsdrehzahl berechnet werden:

$$n_2(U/m) = \frac{V(m/s) \cdot 6 \cdot 10^4}{d_1(mm) \cdot \pi} = \dots(3)$$

V = Geschwindigkeit des Förder-bandes bzw. Aufzugseiles (m/s)
d₁ = Durchschnitt der Umleitrolle (mm)

$$n_2(U/m) = \frac{0,4 \cdot 6 \cdot 10^4}{200 \cdot \pi} = 38,2 U/m$$



Servis Faktörü (S_f)

(Servis Faktörü = İşletme Katsayısı = S_f)

Redüktörlerdeki bu değer, tahrik edeceği makinenin bütün teknik ve karakteristik özelliklerine dayanma süresine bağlıdır. Genel olarak makineler yüklenme bakımından üç tip karakteristik gösterirler.

1. HAFİF YÜK (U)
2. ORTA YÜK (M)
3. AĞIR YÜK (H)

Üç değişik yüklenme biçiminde çalışan, üç ayrı makinede üretilen momentler birbirine eşitte olsalar, ağır çalışan makinede daha büyük işletme katsayılı Redüktör kullanılmaktadır.

Günlük çalışma saati ise, çalışan dişli ve transmisyon elemanlarının malzeme yorulmasına maruz kalması bakımından, çalışma saatinin fazla olması halinde zararlı yönde etki eder.

Star-Stop durumuna gelince, her makinenin ilk kalkış esnasında en yüksek yüke maruz kaldığı düşünülürse tehlikeli görülür. Mütteakip çalışmalarda bu daha aşağıya düşer.

Katalogumuzda işletme katsayılarının nasıl kullanıldığını anlaşılması için bir misal ile belirtelim.

Önce tablo-1'den makinenin çalışma sahasına göre karakteristiğini belirleyelim. Makinemiz elektrik motor tahrikli ZİNCİR KOVALI EKSKAVATÖR ise yüklenme durumu AĞIR' dir. (H)

Tablo 2'den makine 24 saat çalışacağına göre minimum işletme katsayısı $S_f = 2$ bulunur.

Motor gücü 5,5 kW, redüktör çıkış devri 76 d/d ise sayfa 93'ten

Çıkış Devri : 76 d/d
Tahvil Oranı (i) : 18,47
İşletme Katsayısı (S_f) : 2,20

Redüktör seçilmiş olur.

Service Factor (S_f)

Value of the service factor of a gearbox depends on all technical and characteristic specifications of a driven machine. Generally machines have three types of loading characteristics:

1. UNIFORM LOAD (U)
2. MODERATE LOAD (M)
3. HEAVY LOAD (H)

Even if the torques required by three different machines operating at three different load specifications are equal.

Gearbox of the machine operating under heavy load conditions should have greater service factor.

Daily working period has effect on gearbox elements due to the materials fatigue of working parts.

It must be taken into account that all machines are subject to the greatest load at the first start, so that the number of starts has also effect on service factor.

This is an example how to use the service factor given in the catalogue.

Load specification of machine should be determined first, from table 1 in our example, the machine is CHAIN BUCKET EXCAVATOR driven by electric motor has HEAVY load specification and daily operation time is 24 hours. So that minimum service factor $S_f = 2$ is taken from Table 2.

If motor power is 5,5 kW and gearbox output speed is 76 r.p.m. from page 93 a gearbox having;

Output Speed : 76 r.p.m.
Gear Ratio (i) : 18,47
Service factor (S_f) : 2,20

Must be chosen.

Betriebsfaktor (S_f)

Dieser Wert des Hubwerkgetriebes, ist gebunden an die Lebensdauer gegen alle technischen und charakteristischen Eigenschaften der Maschine. Im allgemein sind Maschinen in drei Lastcharaktertypen anzugeben:

1. LEICHTWERTIGE LAST (U)
2. MITTELWERTIGE LAST (M)
3. SCHWERWERTIGE LAST (H)

Wenn die Momente drei verschieden hergestellter Maschinen, die in drei Lastcharaktertypen arbeiten, gleich wahren, benutzt die Maschine mit mittelwertiger Last ein Getriebe mit höherer Betriebszahl.

Die täglichen Betriebsstunden, beeinflussen das Getriebe, je nach Materialermüdung der arbeitenden Zahnwerke und Getriebeelementen, bei längeren Betriebsstunden schädend.

Wenn man bedenkt, dass bei Start-Stop Tätigkeiten jede Maschine der höchsten Last unterliegt, ist es gefährlich. Weiter betriebe ziehen die Leistung herunter.

Wie die Betriebshochzahlen in unserem Katalog benutzt werden, möchten wir Ihnen über ein Beispiel zeigen.

Zuerst werden wir über Tabelle 1 die Charakteristik je nach Arbeitsumgebung feststellen. Wenn unsere Maschine ein KETTENSCHAUFELKRAN mit elektrisch betriebem Motor, dann ist der Lastwert SCHWER (H).

Da die Maschine 24 Stunden in Betrieb sein wird die Mindestbetriebshochzahl nach Tabelle 2 $S_f = 2$ sein.

Wenn die Motorkraft 5,5 kW, Getriebeausgangsdrehzahl 76 rpm ist, dann wird nach Seite 93

Ausgangsdrehzahl : 76 rpm
Umwandlungsgrad (i) : 18,47
Betriebsfaktor (S_f) : 2,20

Getriebe gewählt.

Redüktör Yükleme Karakteristikleri

Load Characteristics of Gearboxes

Belastungskennwerte

EKSKAVATÖRLER

Zincir Kovalı Ekskavatörler	H
Paletli Yürüyüşler	H
Ray Üzerinde Yürüyüşler	M
Manevra Mekanizmaları	U
Emiş Pompaları	M
Kovalı Çarklar	H
Dönüş Mekanizmalar	M

EXCAVATORS

Chain-Bucket excavators	H
Travelling Gears (Caterpillar)	H
Travelling Gears (Rails)	M
Manoevring Winches	U
Pumps	M
Bucket Wheels	H
Slewing Gears	M

BAGGER

Eimerkettenbagger	S
Fahrwerke (Raupe)	S
Fahrwerke (Schiene)	M
Manöverierwinden	G
Saugpumpen	M
Schneidköpfe	S
Wippwerke	M

İNSAAT MAKİNALARI

İnşaat Asansörleri	U
Betoniyerler	M
Yol İnşaat Makinaları	M

BUILDING MACHINES

Hoists	U
Concrete Mixers	M
Road Construction Machines	M

BAUMASSCHİNEN

Baufzüge	G
Betonmischmaschinen	M
Straßenbaumaschinen	M

KALDIRMA VE İLETME TESİSLERİ

CONVEYOR

FÖRDERANLAGEN

Zincirli Konveyör	M
Mafsal Bantlı Konveyörler	M
Lastik Bantlı Konveyörler (Dökme Yükler)	U
Lastik Bantlı Elevatörler	M
Lastik Cepli Elevatörler	M
Lastik Bantlı Konveyörler (Parça Yükler)	M
Askılı Konveyörler	U
Yük Asansörleri	M
Kovalı Elevatörler (Toz Malzeme)	U
Helezon Konveyör	M
Kovalı Elevatörler (Parçalı Malzeme)	M
Eğik Asansörler	H
Çelik Bantlı Konveyörler	M
Paletli Konveyörler	M

Through Chain Conveyors	M
Link Conveyors	M
Belt Conveyors (Bulk Goods)	U
Ballast Elevators	M
Ballast Pocket Elevators	M
Belt Conveyors (Piece Goods)	M
Chain Conveyors	U
Goods Lifts	M
Bucket Elevators (Flour Goods)	U
Screw Conveyors	M
Bucket Elevators (Piece Goods)	M
Inclined Hoists	H
Steel Belt Conveyors	M
Apron Conveyors	M

Trogkettenförderer	M
Gliederbandförderer	M
Gurtbandförderer (Schüttgut)	G
Gurtbandlecherwerke	M
Gurtaschenbecherwerke	M
Gurtbandförderer (Stückgut)	M
Kettenbahnen	G
Lastaufzüge	M
Mehlbecherwerke	G
Scheckenförderer	M
Gurtbecherwerke	M
Scrägaufzüge	S
Stahlbandförderer	M
Plattenbänden	M

Tahrik Makinası Torque Machine Antiebsmaschine	Günlük Çalışma Müddeti (Saat) Daily Working Period (Hour) Tägliche Betriebsdauer (Std.)	Makinanın Yükleme Karakteristiği Load Characteristics of Machines Belastungskennwert der Arbeitsmaschine		
		Hafif Yük U Uniform Load U Gleichmäßige G	Orta Yük M Moderate Load M Mittlere M	Ağır Yük H Heavy Load H Schwere S
Elekt. Motorlu/Elect. Motor/Elek. Motoren	0....3	0.8	1	1.5
Türbin Turbin Turbinen	3....10	1	1.25	1.75
Hidrolik Hydraulic Hydraulik	10...24	1.25	1.5	2
Pistonlu Makinalar (4....6 Silindir) Piston Machines (4....6 Cylindir) Kolbenmaschinen (4....6 Zyl)	0....3	1	1.25	2
	3....10	1.25	1.5	2
	10...24	1.5	1.75	2
Pistonlu Makinalar (1....2 Silindir) Piston Machines (1....2 Cylindir) Kolbenmaschinen (1....2 Zyl)	0....3	1.25	1.5	2
	3....10	1.5	1.75	2.25
	10...24	1.75	2	2.5

Redüktör Yükleme Karakteristikleri

Load Characteristics of Gearboxes

Belastungskennwerte

KİMYA ENDÜSTRİSİ

CHEMICAL INDUSTRY

CHEMISCHE INDUSTRIE

Soğutma Tamburları	M	Cooling Drums	M	Kühltrommeln	M
Karıştırıcılar	M	Mixers	M	Mischer	M
Çalkalayıcılar (Hafif Akışkanlar)	U	Agitators (Liquids)	U	Rührwerke (Leichte Flüssigkeit)	G
Çalkalayıcılar (Ağır Akışkanlar)	M	Agitators (Semi Liquids)	M	Rührwerke (Zähe Flüssigkeit)	M
Tambur Kurutucuları	M	Drying Drums	M	Trockentrommeln	M
Sanrifüjler	U	Centrifuges (Lights)	U	Zentrifugen (Leicht)	G
Sanrifüjler	H	Centrifuges (Heavy)	H	Zentrifugen (Schwer)	S

PETROL ENDÜSTRİSİ

OIL INDUSTRY

ERDÖLGEWINNUNG

Boru Hattı Pompaları	M	Pipeline Pumps	M	Pipeline-Pumpen	H
Kuyu Açma Mekanizmaları	H	Rotary Drilling Equipment	H	Rotary-Bohranlagen	S

VANTİLATÖR VE ASPİRATÖRLER

FANS

GEBLÄSE, LÜFTER

Pistonlu Vantilatörler	M	Rotary Piston Blowers	M	Drehkolbengebläse	M
Vantilatör (Aksiyal ve Radyal)	U	Blowers (Axial and Radial)	U	Gebläse (Axial und Radial)	G
Santrifüj (türbinli) Körük	G	Centrifugal	G	Turbogabläse	G

KAUCUK MAKİNALARI

RUBBER MACHINES

KUNSTSTOFFMASCHINEN

Ekstruder ve Kanderler	H	Extruders and Calenders	H	Extruder	S
Yoğurma Makinaları	H	Pug Mills	H	Knetwerke	S
Karıştırıcılar	M	Mixers	M	Mischer	M
Silindireleme Makinaları	H	Rolling Mills	H	Wälzwerke	S

AĞAC İŞLEME MAKİNALARI

WOOD WORKING MACHINES

HOLZBEARBEITUNGSMASCHINEN

Yontma Tamburları	H	Backers	H	Entrindungsstrommeln	S
Planya Makinaları	M	Planing Machines	M	Hobelmaschinen	M
Ağaç İşleme Tezgahları	U	Wood Working Machines	U	Holzbearbeitungsmaschinen	G
Şerit Testereleler	H	Band Saws	H	Sägegatter	S

YIKAMA MAKİNALARI

WASHING MACHINES

WÄSCHEREIMASCHINEN

Yıkama Makinaları	U	Washing Machines	U	Waschmaschinen	G
Tamburlu Kurutucular	M	Tumblers	M	Trommeltrockner	M

Tahrik Makinası Torque Machine Antiebsmaschine	Günlük Çalışma Müddeti (Saat) Daily Working Period (Hour) Tägliche Betriebsdauer (Std.)	Makinanın Yükleme Karakteristiği Load Characteristics of Machines Belastungskennwert der Arbeitsmaschine		
		Hafif Yük U Uniform Load U Gleichmäßige G	Orta Yük M Moderate Load M Mittlere M	Ağır Yük H Heavy Load H Schwere S
Elekt. Motorlu/Elect. Motor/Elek. Motoren	0....3	0.8	1	1.5
Türbin Turbin Turbinen	3....10	1	1.25	1.75
Hidrolik Hydraulic Hydraulik	10...24	1.25	1.5	2
Pistonlu Makinalar (4....6 Silindir) Piston Machines (4....6 Cylindir) Kolbenmaschinen (4....6 Zyl)	0....3	1	1.25	2
	3....10	1.25	1.5	2
	10...24	1.5	1.75	2
Pistonlu Makinalar (1....2 Silindir) Piston Machines (1....2 Cylindir) Kolbenmaschinen (1....2 Zyl)	0....3	1.25	1.5	2
	3....10	1.5	1.75	2.25
	10...24	1.75	2	2.5

Redüktör Yükleme Karakteristikleri

Load Characteristics of Gearboxes

Belastungskennwerte

VİNC TESİSLERİ

Bom Kaldırma	H
Viç Yürüyüşerleri	U
Yük Kaldırma	H
Dönüş Tertibatları	U

CRANES

Derricking Jib Bomm Gear	H
Travelling Gears	U
Hoist Gears	H
Slewing Gears	U

KRANANLAGEN

Schwenkwerke	S
Fahrwerke	G
Einziehwerke	S
Wippwerke	G

METAL İŞLEME MAKİNALARI

Planya Makineleri	S
Çekiç Tokmak	S
Oyma Makinesi	S
Presler	H
Makaslar (Giyotin)	M
Sıcak Basma Presleri	H
Takım Tezgahları (Ana Tahrir)	M
Takım Tezgahları (Yardımcı Tahrir)	U

METAL WORKING MACHINES

Planing Machine	S
Hammer	S
Engraving Machine	S
Presses	H
Shears	M
Forging Presses	H
Machines Tools (Main Drives)	M
Machines Tools (Auxiliarily Drives)	U

METALLBEARBEITUNGSMASCHINEN

Hobelmaschinen	S
Hammer	S
Stanzenmaschine	S
Walzee	S
Scheren	M
Schmiedepressen	S
Werkzeugmaschinen (Hauptantriebe)	M
Werkzeugmaschinen (Hilfstantriebe)	G

GIDA ENDÜSTRİ MAKİNALARI

Doldurma Makinaları (Şişe, Kavanoz vs.)	U
Yoğurma Makinaları	M
Ambalaj Makinaları	U
Şeker Kamışı Kırıcıları	M
Şeker Kamışı Kesicileri	M
Şeker Kamışı Öğütücüler	H
Şeker Pancarı Kesicileri	M
Şeker Pancarı Yıkayıcıları	M

FOOD INDUSTRY MACHINES

Filling machines (Bottles, Containers..)	U
Kneading Machines	M
Packaging Machines	U
Cane Crushers	M
Cane Cutters	M
Cane Millis	H
Sugar Beet Cutters	M
Suger Beet Washers	M

NAHRUNGSMITTELMASCHINEN

Abfüllmaschinen	G
Knetmaschinen	M
Verpackungsmaschinen	G
Zuckerrohrbrecher	M
Zuckerrohrschneider	M
Zuckerrohrmühlen	S
Zuckerrübenscheider	M
Zuckerrübenwäsche	M

POMPALAR

Pistonlu Pompalar (Q1 / 100)	H
Pistonlu Pompalar (Q1 / 100 : 1 / 20)	M
Türbin (Hafif Akışkan)	U
Türbin (Ağır Akışkan)	M

PUMPS

Piston Pumps (Q1 / 100)	H
Piston Pumps (Q1 / 100 : 1 / 20)	M
Turbin (Light - Liquids)	U
Turbin (Semi - Liquids)	M

PUMPEN

Kolbenpumpen (Q1 / 100)	S
Kolbenpumpen (Q1 / 100 : 1 / 20)	M
Turbinen (Leichte Flüssigkeit)	G
Turbinen (Zähle Flüssigkeit)	M

Tahrir Makinası Torque Machine Antiebsmaschine	Günlük Çalışma Müddeti (Saat) Daily Working Period (Hour) Tägliche Betriebsdauer (Std.)	Makinanın Yükleme Karakteristiği Load Characteristics of Machines Belastungskennwert der Arbeitsmaschine		
		Hafif Yük U Uniform Load U Gleichmäßige G	Orta Yük M Moderate Load M Mittlere M	Ağır Yük H Heavy Load H Schwere S
Elekt. Motorlu/Elect. Motor/Elek. Motoren	0....3	0.8	1	1.5
Türbin Turbin Turbinen	3....10	1	1.25	1.75
Hidrolik Hydraulic Hydraulik	10...24	1.25	1.5	2
Pistonlu Makinalar (4....6 Silindir) Piston Machines (4....6 Cylindir) Kolbenmaschinen (4.....6 Zyl)	0....3	1	1.25	2
	3....10	1.25	1.5	2
	10...24	1.5	1.75	2
Pistonlu Makinalar (1....2 Silindir) Piston Machines (1....2 Cylindir) Kolbenmaschinen (1.....2 Zyl)	0....3	1.25	1.5	2
	3....10	1.5	1.75	2.25
	10...24	1.75	2	2.5



Redüktör Yükleme Karakteristikleri

Load Characteristics of Gearboxes

Belastungskennwerte

KAĞIT ENDÜSTRİ MAKİNALARI

Düzleme Silindirleri	H
Holender	M
Kağıt Hamur Makineleri	H
Kalender	H
Taş Presler	H
Vakum Presler	H
Kuru Silindirler	H

PAPER INDUSTRY MACHINES

Glazing Cylinders	H
Hollenders	M
Pulpers	H
Calender	H
Stone Presses	H
Vacum Presses	H
Drying Cylinders	H

PAPIERMASCHINEN

Glätzzylinder	S
Holländer	M
Gautschen	H
Kalender	S
Steinpressen	S
Vakuumpressen	S
Trockenzylinder	S

TAŞ ve KİL MAKİNALARI

Kırıcılar	H
Döner Fırımlar	M
Çekiçli Değirmenler	H
Bilyalı Değirmenler	H
Çarpmalı Öğütücüler	H
Tuğla Presleri	H

STONE and CLAY WORKING MACHINES

Breakers	H
Rotary Ovens	M
Hammer Mills	H
Ball Mills	H
Beater Mills	H
Brick Presses	H

STEINE - ERDEN

Brecher	S
Drehöfen	M
Hammermühlen	S
Kugelmühlen	S
Schlagmühlen	S
Ziegelpressen	S

TEKSTİL MAKİNALARI

Sargı Makinaları (Q1 / 100)	M
Basma ve Boyama Mak.	M
Dokuma Tezgahları	M

TEXTILE MACHINES

Batchers (Q1 / 100)	M
Printing and Dyeing Machines	M
Looms	M

TEXTILMACHINENS

Webstühle	M
Druckerei	M
Färbereimaschinen	M

KOMPRESÖRLER

Turbo Kompresör	M
-----------------	---

COMPRESSORS

Turbo Compressors	M
-------------------	---

KOMPRESSOREN

Turbokompressoren	M
-------------------	---

SİLİNDİRLEME VE ÇEKME TESİSLERİ

Sac Kesme Makineleri	H
Hız Ayarlı Silindirler	M
Çubuk Kesme Makinaları	H
Kabuk Sıyırma Makinaları	H
Tel Çekme Tesisleri	M
Soğuk Çekme Tesisleri	H
Rulolu Nakil (Hafif)	M
Rulolu Nakil (Ağır)	H
Silindir Haddeleme	H

METAL ROLLING MILLS

Sheet Metal Cutting Machines	H
Roller Adjustment Drivers	M
Billet Shears	H
Descaling Machines	H
Wire Drawing Machines	M
Colling Beds	H
Roller Tables (Lights)	M
Roller Tables (Heavy)	H
Manipulators	H

WÄLZWERKE

Schneidmaschinen	S
Rollenrichtmaschinen	M
Blechscheren	S
Knüppelscheren	S
Drahtzuge	M
Kühlbetten	S
Rollränge (Leicht)	M
Rollränge (Schwer)	S
Stranggubanlagen	S

Tahrik Makinası Torque Machine Antiebsmaschine	Günlük Çalışma Müddeti (Saat) Daily Working Period (Hour) Tägliche Betriebsdauer (Std.)	Makinanın Yükleme Karakteristiği Load Characteristics of Machines Belastungskennwert der Arbeitsmaschine		
		Hafif Yük U Uniform Load U Gleichmäßige G	Orta Yük M Moderate Load M Mittlere M	Ağır Yük H Heavy Load H Schwere S
Elekt. Motorlu/Elect. Motor/Elek. Motoren	0....3	0.8	1	1.5
Türbin Turbin Turbinen	3....10	1	1.25	1.75
Hidrolik Hydraulic Hydraulik	10...24	1.25	1.5	2
Pistonlu Makinalar (4....6 Silindir) Piston Machines (4....6 Cylindir) Kolbenmaschinen (4....6 Zyl)	0....3	1	1.25	2
	3....10	1.25	1.5	2
	10...24	1.5	1.75	2
Pistonlu Makinalar (1....2 Silindir) Piston Machines (1....2 Cylindir) Kolbenmaschinen (1....2 Zyl)	0....3	1.25	1.5	2
	3....10	1.5	1.75	2.25
	10...24	1.75	2	2.5

Radyal Yüklerin Belirlenmesi

Meydana gelen radyal yükün hesaplanabilmesi için redüktörün çıkış veya giriş miline bağlanan iletme elemanının tipi dikkate alınmalıdır. Aşağıdaki tabloda bazı iletme elemanları faktörleri (f_i) verilmiştir.

<u>İletme Elemanı</u>	<u>İletme Elemanı Faktörü (f_i)</u>	<u>Açıklama</u>
Dişli	1,15	< 17 diş
Zincir Dişli	1,40	< 13 diş
Zincir Dişli	1,25	< 20 diş
V-Kayış Kasnakları	1,75	Ön Gerilme Kuvveti
Düz Kayış Kasnakları	2,50	Ön Gerilme Kuvveti
Triger Kayış Kasnakları	1,50	Ön Gerilme Kuvveti

Mil üzerindeki radyal yük aşağıdaki formülle hesaplanır:

$$F_R = \frac{Md \cdot 2000}{d_0} \cdot f_i$$

$F_R [N]$ = Radyal Yük
 $M_d [Nm]$ = Döndürme Momenti
 $d_0 [mm]$ = İletme elemanının Ortalama Çapı
 f_i = İletme Elemanı Faktörü

Bu değerler gözönüne alınarak hesaplanan sonuçlar doğrultusunda, kataloğumuzda yer alan redüktörlere ait radyal yükleri görerek seçim yapabilirsiniz. Bu tablolarda verilen radyal yükler rulman ömrüne göre belirlenmiş olup $S_f = 1$ şartına ve yükün milin ortasını yüklediği durumlar için verilmiştir.

Determining of Overhung Loads

Type of transmission component mounting output or input shaft has to be consideration to find occurred overhung loads. Some transmission component factor (f_i) is given at the table below.

<u>Transmission Component</u>	<u>Transmission Component Factor (f_i)</u>	<u>Explanation</u>
Gear	1,15	< 17 teeth
Sprockets	1,40	< 13 teeth
Sprockets	1,25	< 20 teeth
V-Belt Pulleys	1,75	Pre-tension
Flat Belt Pulleys	2,50	Pre-tension
Trigger Belt Pulleys	1,50	Pre-tension

Overhung Loads on shaft is find by at the formula below:

$$F_R = \frac{Md \cdot 2000}{d_0} \cdot f_i$$

$F_R [N]$ = Overhung Load
 $M_d [Nm]$ = Torque
 $d_0 [mm]$ = Mean Diameter of Transmission Component
 f_i = Transmission Component Factor

You can Choose, by seeing overhung loads belong to gearboxes in our catalog according to determined results by considering these values. The given overhung loads on the tables are determined according to working life, on $S_f = 1$ and force which are applied to the midpoint of the shaft

Bestimmung der Querkrafte

Um die Querkräfte die entstehen zu berechnen muss das Förderungskomponent, das an die Ausgangs-oder Eingangswelle befestigt ist beachtet werden. In der unten angegebenen Tabelle sind die Faktoren (f_i) mancher Förderungskomponenten angegeben.

<u>Übertragungselemente</u>	<u>Übertragungselemente Factor (f_i)</u>	<u>Hinweise</u>
Zahnrad	1,15	< 17 zahne
Kettenrad	1,40	< 13 zahne
Kettenrad	1,25	< 20 zahne
Schmalkeilriemenscheiben	1,75	Durch Vorspannkraft
Flachriemenscheiben	2,50	Durch Vorspannkraft
Zahnriemtriemscheiben	1,50	Durch Vorspannkraft

Die Querkraft auf die Welle der Formel nach berechnet:

$$F_R = \frac{Md \cdot 2000}{d_0} \cdot f_i$$

$F_R [N]$ = Querkraft
 $M_d [Nm]$ = Drehkraft
 $d_0 [mm]$ = Wirkkreisdurchmesser
 f_i = Übertragungselemente Factor

Resultate, die nach Berücksichtigung dieser Werte kalkuliert werden, können Sie die Querkräfte der Getriebe die in unserem Katalog sind vergleichen und und Ihre Entscheidung danach geben. Die Querkräfte die in diesen Tabellen angegeben sind, sind nach Kugellagerlebenszeit festgelegt und der $S_f = 1$ Bedingung und nach Lästern, die auf die Mitte der welle liegen bestimmt worden.

Radyal Yük Hesabı, Çıkış Miline etkiyen Durum için

Calculation of Overhung Load for State Acting on Output Shaft

Berechnung der Querkraft für Abtriebswelle

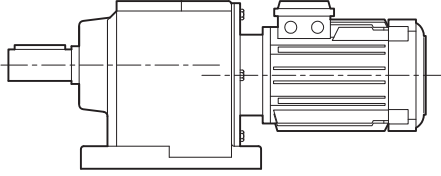
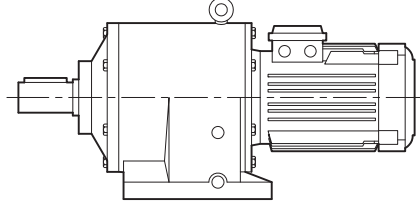
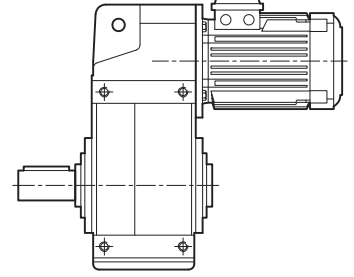
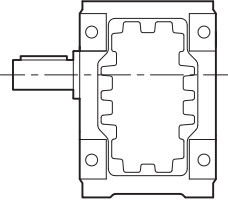
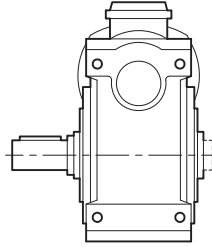
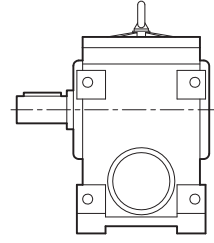
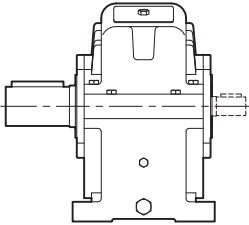
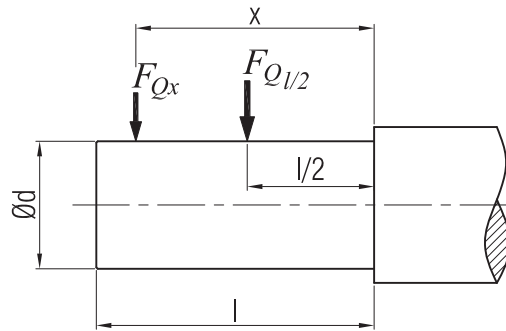
**Monoblok İR Serisi / Monoblok İR Series**
Monoblok İR Serie**İR Serisi / İR Series / İR Serie****YP Serisi / YP Series / YP Serie****İRK Serisi / İRK Series**
İRK Serie**İRS Serisi / İRS Series**
İRS Serie**İRSD Serisi / İRSD Series**
İRSD Serie**A Serisi / A Series / A Serie**

Radyal yük, milin orta noktasında değil ise $F_{Qx} = F_{Q/2} \cdot \frac{k}{c+x}$ formülü ile hesaplanır. Formüldeki "k" ve "c" sabit değerleri sayfa 16'de verilmiştir.

If overhung load is not applied at the midpoint of output shaft; it is calculated by $F_{Qx} = F_{Q/2} \cdot \frac{k}{c+x}$ the fixed values "k" and "c" in the formula is given at page 16.

Ist der Kraftangriff nicht auf wellenmitte, querkraft mit $F_{Qx} = F_{Q/2} \cdot \frac{k}{c+x}$ bestimmen. Die werte "k" und "c" sind in den nachfolgenden tabelle angegeben seite 16.

Radyal Yük Hesabı için Sabit Değerler Tabloları
Tables of Fixed Values for Calculation of Overhung Load
Tabellen der Festwerte für Berechnung der Querkraft

İR Serisi / İR Series / İR Serie (Monoblok)				
Tip/Type/Typ	k	c	d	l
İR 42 - 43	94,5	74,5	20	40
İR 52 - 53	111,1	86,1	25	50
İR 621 - 631	133	108	30	60
İR 62 - 63	143	108	35	70
İR 721-731	153,5	118,5	35	70
İR 72 - 73	169,5	129,5	40	80
İR 82 - 83	209,5	159,5	50	100
İR 92 - 93	242	182	60	120
İR 102 - 103	282	217	70	130
İR 122 - 123	315,25	231	90	170

İR Serisi / İR Series / İR Serie				
Tip/Type/Typ	k	c	d	l
İR 151	431,5	341,5	105	180
İR 181	548,5	443,5	120	210

YP Serisi / YP Series / YP Serie				
Tip/Type/Typ	k	c	d	l
YP 52 - 53	124,5	99,5	25	50
YP 62 - 63	146,5	116,5	30	60
YP 72 - 73	190,25	150,25	40	80
YP 82 - 83	223,65	173,65	50	100
YP 92 - 93	261,5	201	60	120
YP 102 - 103	322,5	252	70	140
YP 122 - 123	390	305	90	170

İRK Serisi / İRK Series / İRK Serie				
Tip/Type/Typ	k	c	d	l
İRK 63	159,5	129,5	30	60
İRK 73	186,25	146,25	40	80
İRK 83	223,65	173,65	50	100
İRK 93	246	186	60	120
İRK 103	312,75	242,75	70	140
İRK 123	393	308	90	170
İRK 143	434	329	110	210

İRS Serisi / İRS Series / İRS Serie				
Tip/Type/Typ	k	c	d	l
İRS 52	120	95	16	40
İRS 65	123,5	96	18	45
İRS 82	145,5	113	24	55
İRS 102	168	128	28	70
İRS 127	207	157	30	80
İRS 162	270	210	45	120
İRS 201	270	195	55	130
İRS 250	304,75	214,75	60	150

İRS D Serisi / İRS D Series / İRS D Serie				
Tip/Type/Typ	k	c	d	l
İRS D 64	144	119	30	50
İRS D 81	180,5	148	38	65
İRS D 101	244	165,5	48	80
İRS D 126	304	211,5	60	100
İRS D 161	330	271	70	120

A Serisi / A Series / A Serie				
Tip/Type/Typ	k	c	d	l
A 200	293,5	228,5	80	130
2A 200	293,5	228,5	80	130
2A 180	227,75	187,75	45	80
2A 225	242	197	55	90
2A 275	270,75	218,25	65	105
2A 350	330,5	265,5	80	130
2A 430	421	331	105	180
2A 501	489,75	384,75	120	210
3A 430	421	331	105	180
3A 501	489,75	384,75	120	210
3A 750	650	525	140	250
4A 750	650	525	140	250

Radyal Yük Hesabı, Giriş Miline etkiyen Durum için

Calculation of Overhung Load for State Acting on Input Shaft

Berechnung der Querkraft für Antriebswelle

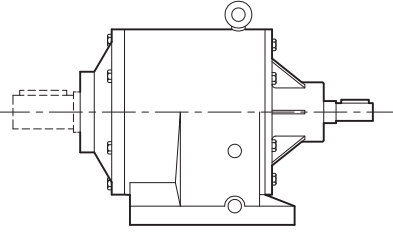

İR Serisi
İR Series / İR Serie

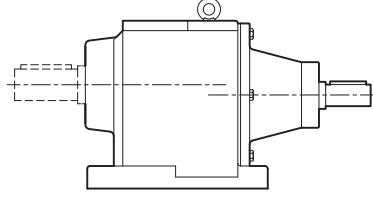

Monoblok İR Serisi
Monoblok İR Series / Monoblok İR Serie

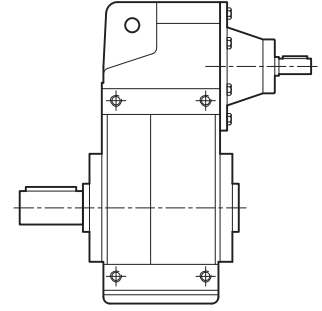

YP Serisi
YP Series / YP Serie

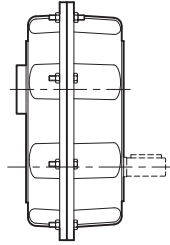

İRO Serisi
İRO Series / İRO Serie

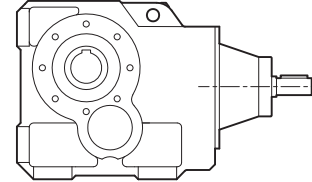

İRK Serisi
İRK Series / İRK Serie

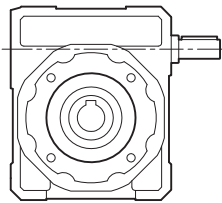

İRS Serisi
İRS Series / İRS Serie

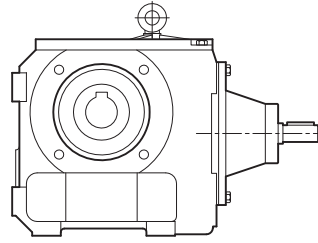

İRSD Serisi
İRSD Series / İRSD Serie

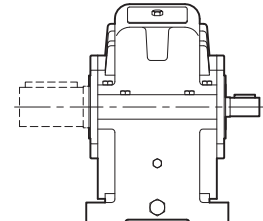

A Serisi
A Series / A Serie

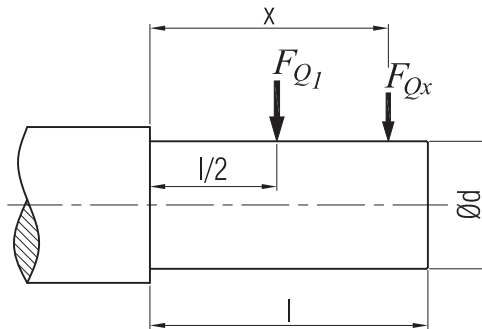

Radyal yük, milin orta noktasında değil ise $F_{Qx} = F_{Q1} \cdot \frac{k}{c+x}$ formülü ile hesaplanır. Formüldeki "k" ve "c" sabit değerleri sayfa 20'de verilmiştir.

If overhung load is not applied at the midpoint of input shaft; it is calculated by $F_{Qx} = F_{Q1/2} \cdot \frac{k}{c+x}$ the fixed values "k" and "c" in the formula is given at page 20.

Ist der Kraftangriff nicht auf wellenmitte, querkraft mit $F_{Qx} = F_{Q1/2} \cdot \frac{k}{c+x}$ bestimmen. Die werte "k" und "c" sind in den nachfolgenden tabelle angegeben seite 20.

Radyal Yük Hesabı için Sabit Değerler Tabloları
Tables of Fixed Values for Calculation of Overhung Load
Tabellen der Festwerte für Berechnung der Querkraft

İR Serisi / İR Series / İR Serie (Monoblok)				
Tip/Type/Typ	k	c	d	l
İR 42 - 43	83.5	63.5	19	40
İR 52 - 53	52.5	67.5	24	50
İR 621 - 631	110	77	24	50
İR 62 - 63	110	77	24	50
İR 721 - 731	119	89	28	60
İR 72 - 73	119	89	28	60
İR 82 - 83	123	88	34	70
İR 92 - 93	159.5	109.5	48	100
İR 102 - 103	187.5	132.5	55	110
İR 122 - 123	231	176	55	110

İR Serisi / İR Series / İR Serie				
Tip/Type/Typ	k	c	d	l
İR 151	242.5	192.5	55	100
İR 181	345	280	70	140

YP Serisi / YP Series / YP Serie				
Tip/Type/Typ	k	c	d	l
YP 52 - 53	83.5	63.5	19	40
YP 62 - 63	52.5	67.5	24	50
YP 72 - 73	110	77	24	50
YP 82 - 83	119	89	28	60
YP 92 - 93	123	88	34	70
YP 102 - 103	159.5	109.5	48	100
YP 122 - 123	187.5	132.5	55	110

İRK Serisi / İRK Series / İRK Serie				
Tip/Type/Typ	k	c	d	l
İRK 63	52.5	67.5	24	50
İRK 73	110	77	24	50
İRK 83	119	89	28	60
İRK 93	123	88	34	70
İRK 103	159.5	109.5	48	100
İRK 123	187.5	132.5	55	110
İRK 143	231	176	55	110

İRO Serisi / İRO Series / İRO Serie				
Tip/Type/Typ	k	c	d	l
İRO 41-A	126.5	101.5	30	50
İRO 41-42	137	111.5	24	50
İRO 51-52	157.25	127.25	28	60
İRO 61-62	180.75	140.75	38	80
İRO 71-72	231	176.25	42	110
İRO 81-82	254	200.25	48	110

İRS Serisi / İRS Series / İRS Serie				
Tip/Type/Typ	k	c	d	l
İRS 52	130	60	16	30
İRS 65	158.5	60.5	18	35
İRS 82	193.75	91.5	24	50
İRS 102	248.25	108	28	60
İRS 127	306.25	120.5	30	60
İRS 162	417.25	129	45	80
İRS 201	501	196	55	100
İRS 250	601	212	60	100

İRS D Serisi / İRS D Series / İRS D Serie				
Tip/Type/Typ	k	c	d	l
İRS D 64	74	59	14	30
İRS D 81	89.5	69.5	19	40
İRS D 101	108.5	83.5	24	50
İRS D 126	139.5	109.5	28	60
İRS D 161	164.5	86	38	80

A Serisi / A Series / A Serie				
Tip/Type/Typ	k	c	d	l
A 200	269.75	162.5	48-55	80-90
2A 200	264.75	154.5	38	60
2A 180	204.25	279	24	50
2A 225	219.25	147.5	28	60
2A 275	252.75	149.5	32	60
2A 350	297.75	180.5	42	80
2A 430	374.25	189.5	45	80
2A 501	420.25	211.5	45	80
3A 430	372.25	193.5	42	80
3A 501	420.25	212.5	42	80
3A 750	350.5	298	60	105
4A 750	321.25	281.25	45	80

Frenler

1) Pervanesiz Frenler

Elektrik motorunun arkasındaki soğutma kapağı takılmayarak bunların yerine monte edilen frenlerdir. Kısa süreli çalışan motorlarda bu tip frenler kullanılır.

2) Pervaneli Frenler

Elektrik motorunun motor mili ve fan kapağı uzatılarak monte edilen frenlerdir. Devamlı çalışan motorlarda bu tip frenler kullanılır.

3) Mikro Anahtarlı Frenler

Elektrik motorlarının demeraj akımının yüksek olması ve freni açmada gecikmesi dolayısıyla istenmeyen durumlar meydana gelir. Bunları önlemek için, frenin üzerine konulan bir mikro anahtar vasıtasıyla freni açtıktan hemen sonra motorun çalışması sağlanır. Bu tip frenler özellikle büyük güçteki redüktörlerin elektrik motorları için uygundur.

Redüktörlerin ani veya Gecikmeli Frenlenmesi

Gecikmeli veya ani frenlenen redüktörler birçok sanayi makinalarında kullanılmaktadır. Bu sebepten frenler hem ani hem de gecikmeli fren yapacak şekilde dizayn edilmişlerdir. Frenlerin elektrik bağlantısında yapılacak bir değişiklikle ani veya gecikmeli frenleme sağlanır. Her frenli redüktör ile birlikte elektrik bağlantı şeması verilmektedir.

Frenli redüktörleri teslim aldığınızda fren bağlantısının gecikmeli olarak yapıldığını unutmayınız.

Brakes

1) Brakes without Cooling Fan

Brake which is mounted on fan side of electric motor by cancelling cooling fan and fan cover of motor. This type of brake is used for a short period running motors.

2) Brakes with Cooling Fan

Brake which is mounted on fan side of electric motor by extending motor shaft and fan cover to use fan. This type of brake is necessary for continuously running motors

3) Brakes with Micro Switch

Because of high starting current of motors delayed disengagement of magnetic brakes undesirable conditions occur. To prevent this situation, starting of motor is provided after disengagement of brake by means of a micro switch installed on the brake. This type of brake is especially suitable for high power geared motors.

Non-Delayed or Delayed Braking of Geared Motors

Delayed or non-delayed geared motors are used in many industrial machines. Therefore, brakes are designed to operate in both delayed and non-delayed conditions. This is supplied with each brake mounted geared motor.

Please do not forget that the brakes are connected for delayed operations standard.

Bremsen

1) Bremsen Ohne Gebläse

Bremsen, die anstelle der Kühlungs-Klappen an das hintere Teil des Elektromotors angebracht werden. Diese Bremsenarten werden bei Motoren eingesetzt, die über einen kurzen Zeitraum laufen.

2) Bremsen mit Gebläse

Bremsen, die montiert werden, indem die Motorwelle und die Gebläseklappe des Elektromotors verlängert werden. Diese Bremsenarten werden bei kontinuierlich laufenden Motoren eingesetzt.

3) Bremsen mit Mikroschalter

Da bei Elektromotoren der Anlaufstrom hoch ist und die Freigabe der Bremsen sich verzögert, treten unerwünschte Folgen auf. Um dies zu vermeiden, wird auf die Bremse ein Mikroschalter angebracht. Mit Hilfe dieses Schalters wird dafür gesorgt, dass der Motor erst nach Freigabe der Bremse startet. Diese Bremsenarten sind besonders für Elektromotoren von leistungsstarken Getriebemotoren geeignet.

Die schlagartige oder verzögerte Bremsung von Getriebemotoren

Getriebemotoren mit schlagartiger oder verzögerter Bremsung werden für vielzählige Industriemaschinen angewendet. Deswegen sind die Bremsen so konstruiert, dass sie sowohl schlagartig als auch verzögert bremsen können. Ein schlagartiges oder verzögertes Bremsen kann erreicht werden, indem man an der Stromverbindung der Bremsen eine Änderung vornimmt. Jedem Getriebe-Motor wird auch ein Storm-Verbindungsschema beigelegt.

Bitte vergessen Sie nicht, dass die Standardausführung der gelieferten Getriebemotoren mit einer Brems-Verbindung für verzögertes Bremsen versehen ist.

Fren Çalışma Voltajları

Frenler 24V-DC veya 220V-AC ile çalışacak şekilde imal edilir. 220 voltluk frenlerin bağlantıları motor klemens kutusunda yapılmaktadır. 24V ile çalışan frenlerin bağlantısı için ayrıca 220/30V trafo ile doğrultucu gerekmektedir. İstenildiğinde bunlar firmamızca temin edilmektedir.

Frenli redüktörlerin elektrik motorlarına toprak hattı bağlantısı muhakkak yapılmalıdır.

Fren Siparişlerinde Belirtilmesi Gereken Hususlar

- 1) Fren Momenti
- 2) Fren Tipi
- 3) Fren voltajı

24V ile çalışan fren siparişlerinde trafolu doğrultucu istenip istenmediğini lütfen belirtiniz.

Operating Voltage of Brakes

Brakes are manufactured to operate at 24V-DC or 220V-AC. 220V brakes are connected to the motor terminal box directly, but 220/30V transformer with rectifier unit needed for 24V operating brakes. This unit will be supplied if required.

Geared brake motors must be earthed.

Required ordering Data for Brakes

- 1) Brake Torque
- 2) Brake Type
- 3) Brake Operating Voltage.

Please inform as if you need 220/30V transformer with rectifier unit for 24V operating brakes

Betriebsspannung der Bremsen

Die Bremsen werden in der Ausführung mit Betriebsspannung von 24V-DC oder 220V-AC hergestellt. Die Verbindungen der 220V Bremsen werden an die Anschlussbox des Motors angebracht. Für die Verbindung der 24V Bremsen benötigt man außerdem einen 220/30V Transformator und einen Stromrichter. Auf Anfrage können diese von unserer Fa. geliefert werden.

Die Elektromotoren der Getriebe-Motoren mit Bremsen müssen auf jeden Fall an eine Erdleitung verbunden sein.

Anzugebende Informationen für einen Bremsen-Auftrag

- 1) Bremsmoment
- 2) Bremsenart
- 3) Betriebsspannung der Bremsen.

Bei Bremsen mit 24V Betriebsspannung, bitte angeben, ob ein Stromrichter mit Transformator erwünscht ist.

Fren Bağlantı Şemaları

Brake Connection Types

Verbindungsschema der Bremse

Gecikmeli Frenleme (24V)

Delayed Running Brake (24V)
Verspärterte Bremsung (24 V)

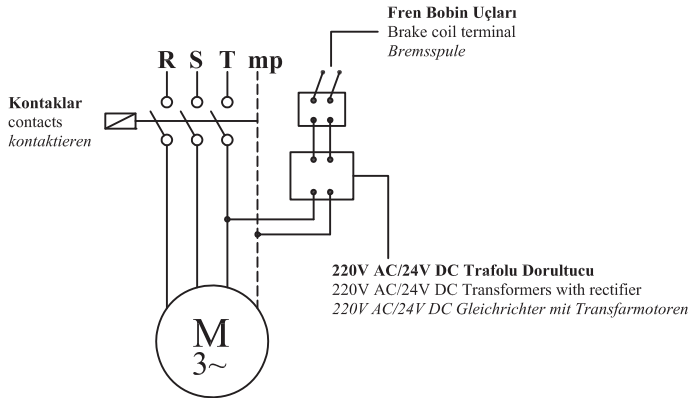

Ani Frenleme (24V)

Sudden Running Brake (24V)
Gleichzeitige Bremsung (24 V)

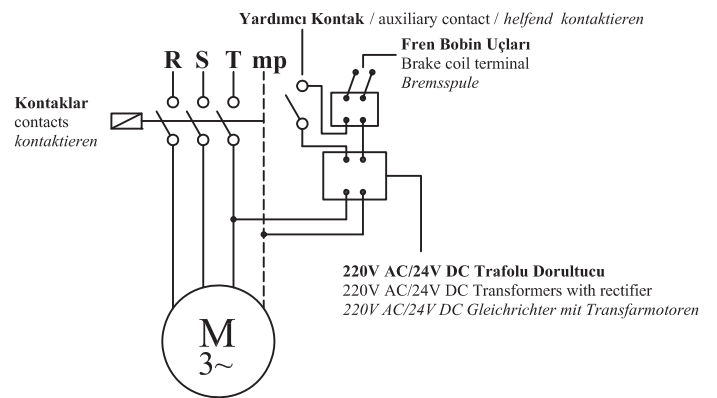

Gecikmeli Frenleme (220V)

Delayed Running Brake (220V)
Versparterte Bremsung (220 V)

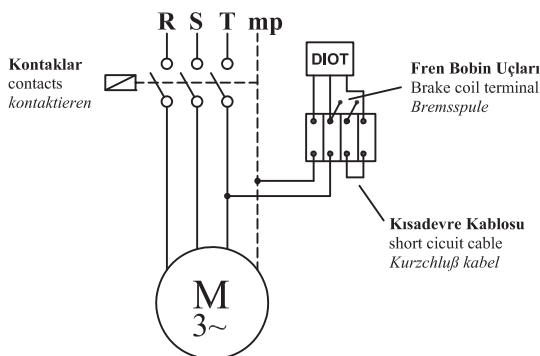

Ani Frenleme (220V)

Sudden Running Brake (220V)
Gleichzeitige Bremsung (220 V)

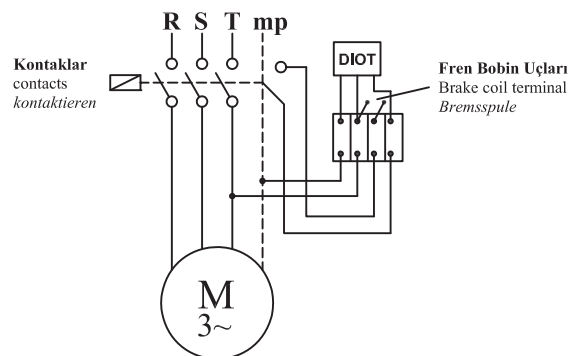

Tablo 1 / Table 1 / Tabellen 1

Motor Büyüklüğü Motor Size Motor baugröße	n ₁ d/d / r.p.m / U/m			
	750	1000	1500	3000
	Güç / Power / Leistung [kW]			
63			0,12 - 0,18	0,18 - 0,25
71	0,09 - 0,12	0,18 - 0,28	0,25 - 0,37	0,37 - 0,55
80	0,18 - 0,25	0,37 - 0,55	0,55 - 0,75	0,75 - 1,1
90 S	0,37	0,75	1,1	1,5
90 L	0,55	1,1	1,5	2,2
100	0,75 - 1,1	1,5	2,2 - 3	3
112	1,5	2,2	4	4
132 S	2,2	3	5,5	5,5 - 7,5
132 M	3	4 - 5,5	7,5	11
160 M	4-5,5	7,5	11	15
160 L	7,5	11	15	18,5
180 M			18,5	22
180 L	11	15	22	
200	15	18,5 - 22	30	30 - 37
225 S	18,5		37	
225 M	22	30	45	45
250	30	37	55	55
280 S	37	45	75	75
280 M	45	55	90	90

Tablo 2 / Table 2 / Tabellen 2

Motor Büyüklüğü Motor Size Motor baugröße	Fren Momenti [kgm] Braking Torque [kgm] Bremsmomente [kgm]																			
	Hafif Frenleme Light Braking Licht Bremsung										Kuvvetli Frenleme Strong Braking Stark Bremsung									
	0,5	1	2,5	4	5	10	20	30	50	80	0,5	1	2,5	4	5	10	20	30	50	80
63	■										■									
71	■	■									■	■								
80	■	■	■								■	■	■							
90 S		■	■	■								■	■	■						
90 L			■	■	■								■	■	■					
100				■	■	■								■	■	■				
112					■	■	■								■	■	■			
132 S						■	■	■								■	■	■		
132 M							■	■	■								■	■	■	
160 M								■	■	■								■	■	■
160 L									■	■	■								■	■
180 M										■	■	■								■
180 L											■	■	■							■
200												■	■	■						■
225 S													■	■	■					■
225 M														■	■	■				■
250															■	■	■			■
280 S																■	■	■		■
280 M																	■	■	■	■

Kontrol ve Bakım Redüktörler

►Redüktörlerin yağ seviyesi ve miktarını kontrol ediniz. Yağın cinsini İ.MAK kataloğunda yer alan yağ çizelgelerini kullanarak seçiniz.

►Havalandırma tapasının faal olup olmadığına bakınız. Hava tahliye deliği çalışmaz ise redüktör gövdesinin içinde biriken hava, basınç oluşturarak keçelerden yağ sızmasına sebep olur. Böylece yağ azalarak çevre kirliliğine yol açar ve redüktörün verimli çalışmasını engellemiş olur.

►Redüktör bağlantı civatalarının gevşeyip gevşemediğini kontrol ediniz, gevşeyen civatalar var ise sıkılaşma suretiyle tedbir alınır. Redüktör montajında meydana gelen eksen kaçıklığında zararlı sarsıntılara dikkat ediniz.

►Redüktörün ilk çalıştırmadan 500 saat sonra, sonraki her 6000 saatte periyodik olarak yağın değiştirilmesini.

►Özel hususlar ve çalışma şartları hakkında mutlaka firmamıza danışınız.

Kayışlı Varyatörler

►Varyatörün ilgili yerlerindeki graslüklerden belli aralıklarla yağ basılması gereklidir.

►Varyatörün devir aralığı tespit civatasının ayarı bozulmamalıdır. Bu ayarın bozulması durumunda max./min. Devir sınır değerlerini aşması kayışta istenmeyen tahribatlara yol açabilir.

►Varyatör regülasyon sisteminin devamlı ve iyi çalışması için arada bir (hafta sonu) devrini birkaç dakika için değiştirip çalıştırmakta fayda vardır.

►Mümkün olduğu kadar tozlu ortamın etkisinden korunmak için tedbir alınmalıdır.

►Varyatör devir aralığı mutlaka varyatör çalışırken yapılmalıdır.

Control and Maintenance Gearboxes

►Check the oil levels and quantity of your motors. Chose the type and quantity of oil from the İ.MAK catalogue.

►Check if the ventilation stopper is active or not. If the air evacuation hole does not work, the accumulated air in the motor trunk causes pressure and gas leakage from the mats. Thus the oil reduces and causes environmental is pollution and hinders the efficient operation of the motor.

►Check wether the motor connection bolts have loosened or not. Take measures by firming loosened bolts. Be careful for the harmful shaking of the disposition of the axis during motor installation.

►Change the oil after 500 hours of initial operation and periodically every 6000 hours of operating the motor.

►You must contact and consult with our company for special matters and operation conditions.

Belt Variators

►It is necessary to apply oil from the greaser at the relevant parts of the belt variators periodically.

►The adjustment of the rotation interval fixing bolt of the belt variator should not be changed. In case these intervals are changed and the max/min rotation limit values are exceeded, it may cause uninvited damage on the belt.

►It is beneficial to change and operate the rotation of the belt variator regulation system for a few minutes once in a while (at weekends) for the continuous and proper operation of the machine.

►Relevant precautions should be taken to protect from the dusty environments effects as much as possible.

►The rotation interval of the belt variator must be done during the operation of the variator.

Kontrolle und Pflege Getriebe

►Kontrollieren Sie den Öl- Stand und Gehalt des Hubwerkgetriebes. Wählen Sie die Ölsorte gemäß im I.MAK Katalog angegebenen Öltabelle.

►Kontrollieren Sie, ob der Luftverschluss tätig ist. Falls die Belüftungsöffnung nicht funktioniert, kann die Luft, die sich im Getriebegehäuse sammelt, Druck erzeugen und Öl in die Filze durchdringen. Dadurch verringert sich der Ölstand und gefährdet die Umwelt und verhindert die Leistung des Getriebes.

►Kontrollieren Sie, ob die Schrauben locker sind. Falls entspannte Schrauben vorhanden sind, sichern Sie, dass sie angezogen sind. Beachten Sie, während der Getriebemontage auftauchenden axialen Entweichungen auf schädliche Erschütterungen.

►Wechseln Sie Regelmäßig das Öl, zuerst 500 Stunden nach dem ersten Betrieb, und danach alle 6000 Stunden.

►Über besondere Themen und Arbeitsbedingungen wenden Sie sich unbedingt an unsere Firma.

Verstell

►In regelmäßigen Abständen muss in die Ölbuchsen des Verstell Öl gepumpt werden

►Die Einstellung der Drehzahlbefestigungsschraube darf nicht sich nicht verziehen. Bei einer Entweichung können die max/min Drehzahlgrenzen überschritten werden und unerwünschte Schaden hinterlassen.

►Damit das Verstellregulationssystem dauerhaft leistungsfähig im Gang bleibt, ist es nützlich ab und zu (am Wochenende) die Drehzahl für en paar Minuten zu wechseln und in Betrieb zu setzen.







►Es sollten Maßnahmen getroffen werden um so weit wie möglich gegen die Einflüsse von Staub zu schützen.

►Die Drehzahl des Verstell muss unbedingt während des Betriebs des Verstell geregelt werden wir Ihnen über ein Beispiel zeigen.

Yağ Tablosu

Lubricant Table

Schmiere Tabelle

Yağ Cinsi Lubricant Art des Schmierstoffes	ISO Viskozite Sınıfı ISO Viscosity Class Viskozitäts Klasse ISO	Kullanım Sıcaklığı Usage Temperature Gebrauchstemperatur	Firma Firm Firma						
									
Mineral Yağ Mineral Oil Minerallöl	ISO VG 320	0.....+100	Degol BG 320	Mobilgear 632	Energol GR-XP320	Omala 320	Belgear M-320-Süper	GEM 1 320	Spartan EP 320
	ISO VG 220	-5.....+100	Degol BG 220	Mobilgear 630	Energol GR-XP220	Omala 220	Belgear M-220-Süper	GEM 1 220	Spartan EP 220
	ISO VG 150	-5.....+100	Degol BG 150	Mobilgear 629	Energol GR-XP150	Omala 150	Belgear M-150-Süper	GEM 1 150	Spartan EP 150
	ISO VG 100	-5.....+100	Degol BG 100	Mobilgear 627	Energol GR-XP100	Omala 100	Belgear M-100-Süper	GEM 1 100	Spartan EP 100
Sentetik Yağ Synthetic Oil Synthetisch Öl	ISO VG 320	-25.....+140	Degol GS 320	Gylgoyle 320	Enersyn SG-XP320			Syntheso D 320 EP	Glycolube 320
	ISO VG 220	-25.....+140	Degol GS 220	Gylgoyle 220	Enersyn SG-XP220	Tivela WB		Syntheso D 220 EP	
	ISO VG 150	-30.....+140	Degol GS 150		Enersyn SG-XP150			Syntheso D 150 EP	
	ISO VG 100	-30.....+140			Enersyn SG-XP100			Syntheso D 100 EP	

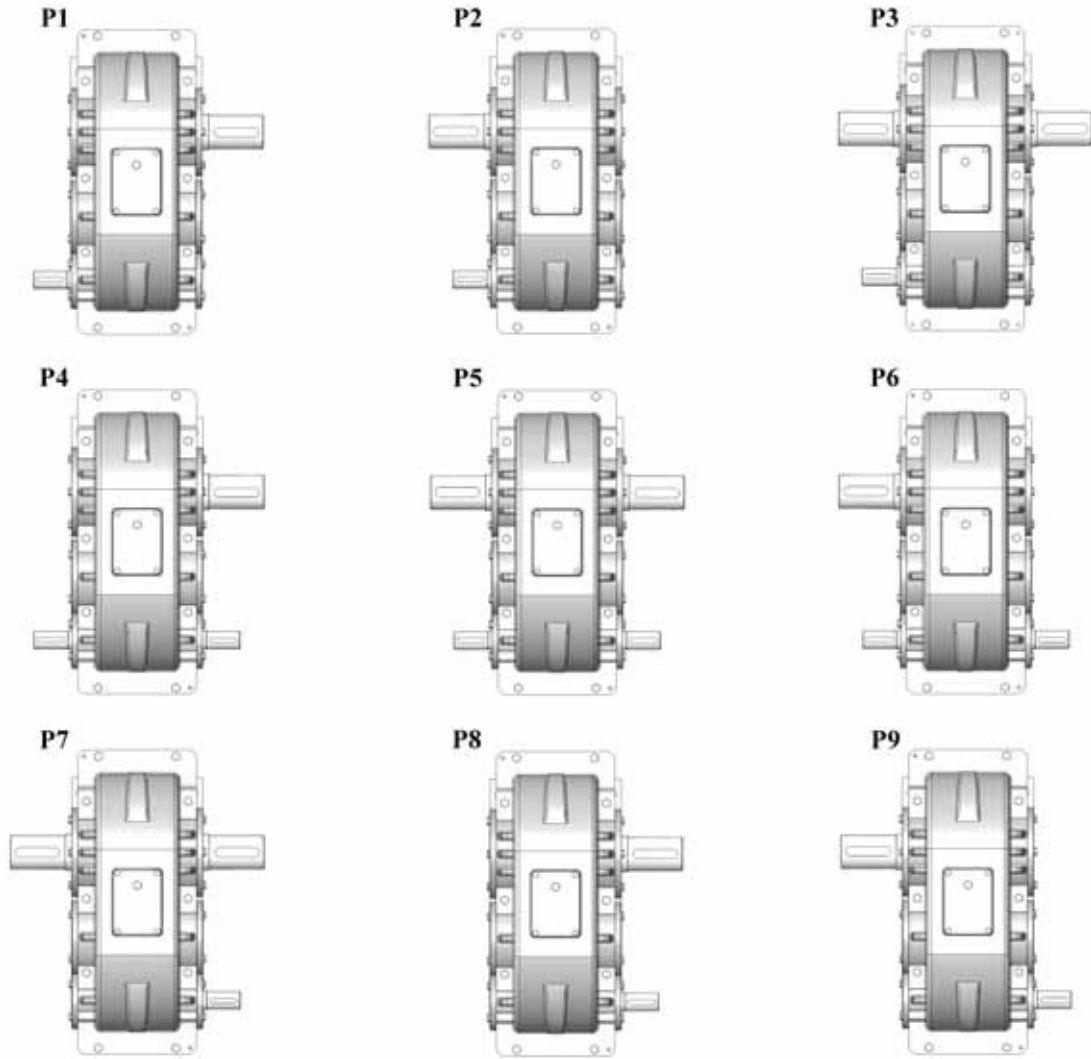

TİP Type Typ	Bağlantı Pozisyonları için Yağ Miktarları (litre) Oil Quantities for Mounting Positions (liter) Ölmengen Tabellen für Bauformen (liter)								
	P1	P2	P3	P4	P5	P6	P7	P8	P9
A 200					10				
2A 200					10				
2A 180					4				
2A 225					7				
2A 275					10				
2A 350					18				
2A 430					25				
2A 501					32				
3A 430					25				
3A 501					32				
3A 750					65				
4A 750					65				

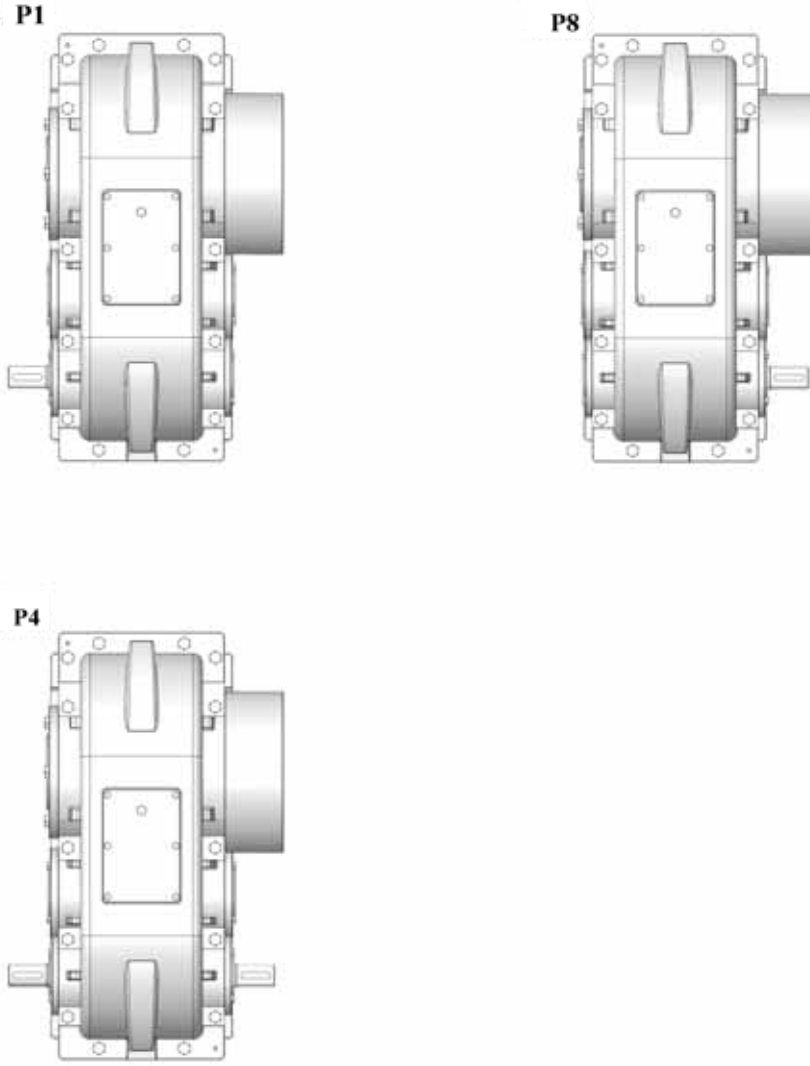

TİP Type Typ	Bağlantı Pozisyonları için Yağ Miktarları (litre) Oil Quantities for Mounting Positions (liter) Ölmengen Tabellen für Bauformen (liter)		
	P1	P4	P8
2AE 225		7	
2AE 275		10	
2AE 350		18	
2AE 430		25	
2AE 501		32	
3AE 430		25	
3AE 501		32	
3AE 750		65	

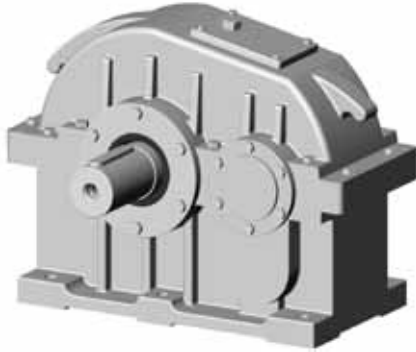

A ...

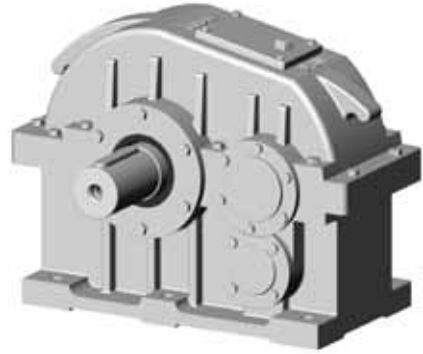

2A 200

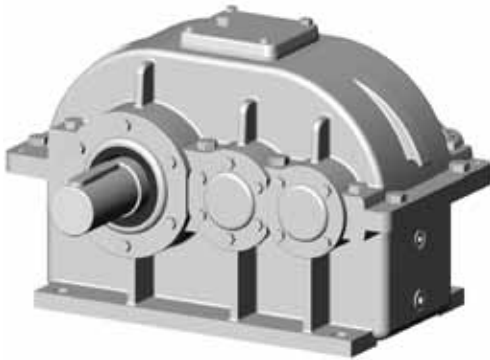

2A ...

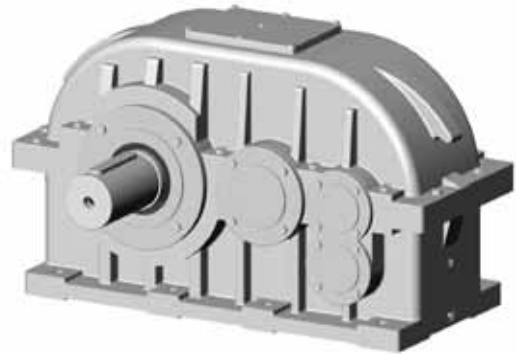

3A ...

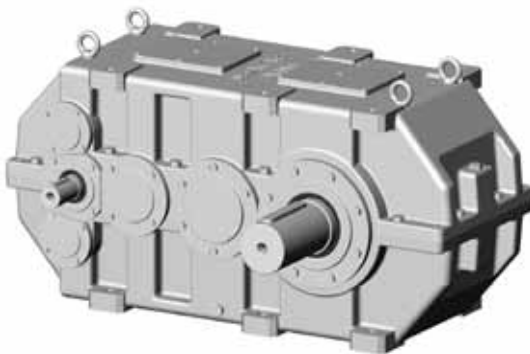

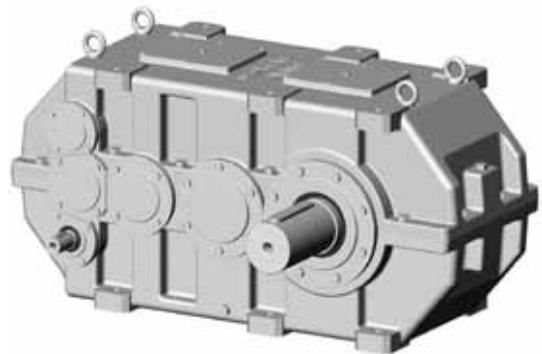

3A 750





4A 750





İ Tahvil Oranı Ratio Übersetzung	n ₁	n ₂	P ₁	S _f	M ₂	F _{q1}	F _{qv2}	Tip Type Typ			kg
	Giriş Devri	Çıkış Devri	GÜÇ	Servis Faktörü	Çıkış Momenti	Rad. Yük	Rad. Yük				
	Input Speeds	Output Speeds	Power	Service Factor	Output Torque	Over Loads	Over Loads				
	Antriebswelle Drehzahlen	Abtriebswelle Drehzahlen	Leistung	Betriebsfaktor	Abtriebswelle Drehmomente	Querkräfte	Querkräfte				
	[r.p.m]	[r.p.m]	[kW]		[Nm]	[N]	[N]				
1.71	1400	820	132	3,57	1514	3700	24000	A 200	658	190	
			110	4,29	1262	3700	24000				
			90	5,25	1032	3700	24000				
	900	525	110	2,86	1971	3700	24800				
			90	3,50	1613	3700	24800				
			75	4,20	1344	3700	24800				
	700	410	90	2,83	2065	3700	25750				
			75	3,40	1344	3700	25750				
			55	4,63	1262	3700	25750				
	500	290	75	2,45	2433	3700	26500				
			55	3,34	985	3700	26500				
			45	4,08	1460	3700	26500				
1.87	1400	745	132	3,40	1667	3700	24000				
			110	4,09	1389	3700	24000				
			90	5,00	1136	3700	24000				
	900	480	110	2,27	2156	3700	24800				
			90	3,33	1764	3700	24800				
			75	4,00	1470	3700	24800				
	700	370	90	2,66	2288	3700	25750				
			75	3,20	1907	3700	25750				
			55	4,36	1398	3700	25750				
	500	270	75	2,30	2613	3700	26500				
			55	3,13	1916	3700	26500				
			45	3,83	1568	3700	26500				
2.06	1400	680	132	3,23	1826	3700	24000				
			110	3,88	1522	3700	24000				
			90	4,75	1245	3700	24000				
	900	440	110	2,42	2352	3700	24800				
			90	2,95	1324	3700	24800				
			75	3,55	1603	3700	24800				
	700	340	90	2,50	2490	3700	25750				
			75	3,00	2075	3700	25750				
			55	4,09	1522	3700	25750				
	500	240	75	2,15	2940	3700	26500				
			55	2,93	2156	3700	26500				
			45	3,58	1764	3700	26500				
2.27	1400	615	132	3,23	2019	3700	24000				
			110	3,88	1683	3700	24000				
			90	4,75	1377	3700	24000				
	900	395	110	3,04	2620	3700	25750				
			90	3,65	2143	3700	25750				
			75	4,46	1786	3700	25750				
	700	310	90	2,42	2731	3700	25750				
			75	2,96	2276	3700	25750				
			55	3,55	1669	3700	25750				
	500	220	75	2,01	3207	3700	26500				
			55	2,75	2352	3700	26500				
			45	3,36	1924	3700	26500				





İ Tahvil Oranı Ratio Übersetzung	n ₁	n ₂	P ₁	S _f	M ₂	F _{q1}	F _{q2}	Tip Type Typ			kg
	Giriş Devri	Çıkış Devri	GÜÇ	Servis Faktörü	Çıkış Momenti	Rad. Yük	Rad. Yük				
	Input Speeds	Output Speeds	Power	Service Factor	Output Torque	Over Loads	Over Loads				
	Antriebswelle Drehzahlen	Abtriebswelle Drehzahlen	Leistung	Betriebsfaktor	Abtriebswelle Drehmomente	Querkräfte	Querkräfte				
	[r.p.m]	[r.p.m]	[kW]		[Nm]	[N]	[N]				
2.51	1400	555	110	3,4	1864	3700	24000	A 200	658	190	
			90	4,15	1525	3700	24000				
			75	4,98	1271	3700	24000				
	900	360	90	2,78	2352	3700	25750				
			75	3,33	1960	3700	25750				
			55	4,55	1437	3700	25750				
	700	280	75	2,60	2520	3700	26500				
			55	3,55	1840	3700	26500				
			45	4,33	1512	3700	26500				
	500	200	55	2,60	2587	3700	26500				
			45	3,17	2117	3700	26500				
			37	3,86	1740	3700	26500				
2.80	1400	500	110	3,20	2069	3700	24800				
			90	3,91	1693	3700	24800				
			75	4,69	1411	3700	24800				
	900	320	90	2,62	1693	3700	25750				
			75	3,15	1411	3700	25750				
			55	4,20	1035	3700	25750				
	700	250	75	2,42	2822	3700	26500				
			55	3,30	2069	3700	26500				
			45	4,03	1693	3700	26500				
	500	180	55	2,40	2874	3700	26500				
			45	2,93	2352	3700	26500				
			37	3,56	1934	3700	26500				
3.13	1400	450	110	2,92	2299	3700	24800				
			90	3,57	1881	3700	24800				
			75	4,29	1568	3700	24800				
	900	290	90	2,35	2919	3700	25750				
			75	2,82	2433	3700	25750				
			55	3,85	1784	3700	25750				
	700	225	75	2,23	3136	3700	26500				
			55	3,05	2299	3700	26500				
			45	3,73	1881	3700	26500				
	500	160	55	2,20	3234	3700	26500				
			45	2,68	2646	3700	26500				
			37	3,27	2175	3700	26500				
3.52	1400	400	90	3,26	2117	3700	25750				
			75	3,92	1764	3700	25750				
			55	5,34	1293	3700	25750				
	900	255	75	2,60	2767	3700	26500				
			55	3,54	2029	3700	26500				
			45	4,33	1660	3700	26500				
	700	200	55	2,78	2587	3700	26500				
			45	3,40	2117	3700	26500				
			37	4,13	1740	3700	26500				
	500	140	45	2,43	3024	3700	26500				
			37	2,96	2486	3700	26500				
			30	3,65	2016	3700	26500				





İ Tahvil Oranı Ratio Übersetzung	n ₁	n ₂	P ₁	S _f	M ₂	F _{q1}	F _{q2}	Tip Type Typ	  kg	
	Giriş Devri	Çıkış Devri	GÜÇ	Servis Faktörü	Çıkış Momenti	Rad. Yük	Rad. Yük			
	Input Speeds	Output Speeds	Power	Service Factor	Output Torque	Over Loads	Over Loads			
	Antriebswelle Drehzahlen	Abtriebswelle Drehzahlen	Leistung	Betriebsfaktor	Abtriebswelle Drehmomente	Querkräfte	Querkräfte			
	[r.p.m]	[r.p.m]	[kW]		[Nm]	[N]	[N]			
4.00	1400	350	90	3,00	2419	3700	25750	A 200	658	190
			75	3,60	2016	3700	25750			
			55	4,90	1478	3700	25750			
	900	225	75	2,32	3136	3700	26500			
			55	3,16	2299	3700	26500			
			45	3,86	1881	3700	26500			
	700	175	55	2,51	2956	3700	26500			
			45	3,06	2419	3700	26500			
			37	3,73	1989	3700	26500			
	500	125	45	2,20	3386	3700	27250			
			37	2,67	2784	3700	27250			
			30	3,30	2258	3700	27250			
4.58	1400	305	90	2,66	2776	3700	25750			
			75	3,20	2313	3700	25750			
			55	4,36	1696	3700	25750			
	900	195	75	2,08	3618	3700	26500			
			55	2,83	2653	3700	26500			
			45	3,46	2171	3700	26500			
	700	150	55	2,21	3449	3700	26500			
			45	2,70	2822	3700	26500			
			37	3,28	2320	3700	26500			
	500	110	45	1,93	3848	3700	27250			
			37	2,35	3164	3700	27250			
			30	2,90	2565	3700	27250			
4.93	1400	285	75	3,00	2475	3700	26500			
			55	4,09	1815	3700	26500			
			45	5,00	1485	3700	26500			
	900	180	55	2,65	2874	3700	26500			
			45	3,23	2352	3700	26500			
			37	3,93	1934	3700	26500			
	700	140	45	2,53	3024	3700	26500			
			37	3,08	2486	3700	26500			
			30	3,80	2016	3700	26500			
	500	100	37	2,23	3480	3700	27250			
			30	2,75	2822	3700	27250			
			22	3,75	2069	3700	27250			
5.33	1400	260	75	2,80	2713	3700	26500			
			55	3,82	1990	3700	26500			
			45	4,66	1628	3700	26500			
	900	170	55	2,45	3043	3700	26500			
			45	3,00	2490	3700	26500			
			37	3,65	2047	3700	26500			
	700	130	45	2,33	3256	3700	27250			
			37	2,84	2677	3700	27250			
			30	3,50	2171	3700	27250			
	500	95	37	2,06	3664	3700	27250			
			30	2,55	2971	3700	27250			
			22	3,48	2178	3700	27250			





İ Tahvil Oranı Ratio Übersetzung	n ₁	n ₂	P ₁	S _f	M ₂	F _{q1}	F _{q2}	Tip Type Typ			kg
	Giriş Devri	Çıkış Devri	GÜÇ	Servis Faktörü	Çıkış Momenti	Rad. Yük	Rad. Yük				
	Input Speeds	Output Speeds	Power	Service Factor	Output Torque	Over Loads	Over Loads				
	Antriebswelle Drehzahlen	Abtriebswelle Drehzahlen	Leistung	Betriebsfaktor	Abtriebswelle Drehmomente	Querkräfte	Querkräfte				
	[r.p.m]	[r.p.m]	[kW]		[Nm]	[N]	[N]				
5.78	1400	240	75	2,60	2940	3700	26500	A 200	658	190	
			55	3,55	2156	3700	26500				
			45	4,33	1764	3700	26500				
	900	155	55	2,29	3338	3700	26500				
			45	2,80	2731	3700	26500				
			37	3,41	2245	3700	26500				
	700	120	45	2,20	3528	3700	27250				
			37	2,67	2900	3700	27250				
			30	3,30	2352	3700	27250				
	500	85	37	1,90	4095	3700	27250				
			30	2,35	3320	3700	27250				
			22	3,20	2435	3700	27250				
6.30	1400	220	75	2,40	3207	3700	26500				
			55	3,27	2352	3700	26500				
			45	4,00	1924	3700	26500				
	900	140	55	2,10	3696	3700	26500				
			45	2,56	3024	3700	26500				
			37	3,11	2486	3700	26500				
	700	110	45	2,00	3848	3700	27250				
			37	2,43	3164	3700	27250				
			30	3,00	2565	3700	27250				
	500	80	37	1,74	4351	3700	27250				
			30	2,15	3528	3700	27250				
			22	2,93	2587	3700	27250				
6.91	1400	200	75	2,73	3528	3700	26500				
			55	3,32	2587	3700	26500				
			45	4,10	2117	3700	26500				
	900	130	55	2,20	3980	3700	27250				
			45	3,00	3256	3700	27250				
			37	3,66	2677	3700	27250				
	700	100	45	1,93	4233	3700	27250				
			37	2,36	3480	3700	27250				
			30	2,87	2822	3700	27250				
	500	72	37	1,93	4834	3700	27250				
			30	2,23	3919	3700	27250				
			22	2,75	2874	3700	27250				
7.17	1400	195	45	2,73	2138	3700	26500				
			37	3,32	1758	3700	26500				
			30	3,48	1425	3700	26500				
	900	125	37	2,07	2742	3700	27250				
			30	2,55	2223	3700	27250				
			22	3,48	1630	3700	27250				
	700	100	30	2,15	2779	3700	27250				
			22	2,94	2038	3700	27250				
			18,5	3,50	1714	3700	27250				
	500	70	22	2,11	2911	3700	27250				
			18,5	2,50	2448	3700	27250				
			15	3,09	1985	3700	27250				





i Tahvil Oranı Ratio Übersetzung	n₁	n₂	P₁	S_f	M₂	F_{q1}	F_{q2}	Tip Type Typ	  kg	
	Giriş Devri	Çıkış Devri	GÜÇ	Servis Faktörü	Çıkış Momenti	Rad. Yük	Rad. Yük			
	Input Speeds	Output Speeds	Power	Service Factor	Output Torque	Over Loads	Over Loads			
	Antriebswelle Drehzahlen	Abtriebswelle Drehzahlen	Leistung	Betriebsfaktor	Abtriebswelle Drehmomente	Querkräfte	Querkräfte			
	[r.p.m]	[r.p.m]	[kW]		[Nm]	[N]	[N]			
7.91	1400	180	37	3,12	1904	3700	26500			
			30	3,85	1544	3700	26500			
			22	5,25	1132	3700	26500			
	900	115	30	2,55	2417	3700	27250			
			22	3,49	1772	3700	27250			
			18,5	4,15	1490	3700	27250			
	700	90	22	2,76	2264	3700	27250			
			18,5	3,29	1904	3700	27250			
			15	4,05	1544	3700	27250			
	500	60	18,5	2,35	2856	3700	27800			
			15	2,89	2316	3700	27800			
			11	3,95	1698	3700	27800			
8.75	1400	160	37	2,91	2142	3700	26500			
			30	2,58	1737	3700	26500			
			22	4,90	1274	3700	26500			
	900	100	30	2,40	2779	3700	27250			
			22	3,27	2038	3700	27250			
			18,5	3,89	1714	3700	27250			
	700	80	22	2,55	2547	3700	27250			
			18,5	3,03	2142	3700	27250			
			15	3,74	1737	3700	27250			
	500	60	18,5	2,22	2142	3700	27800			
			15	2,73	1737	3700	27800			
			11	3,73	1274	3700	27800			
9.73	1400	145	37	2,77	2364	3700	26500	2A 200	659	215
			30	3,42	1917	3700	26500			
			22	4,67	1405	3700	26500			
	900	90	30	2,21	3088	3700	27250			
			22	3,02	2264	3700	27250			
			18,5	3,60	1904	3700	27250			
	700	70	22	2,37	2911	3700	27250			
			18,5	2,82	2448	3700	27250			
			15	3,48	1985	3700	27250			
	500	50	18,5	2,04	3427	3700	27800			
			15	2,52	2779	3700	27800			
			11	3,44	2038	3700	27800			
10.88	1400	130	30	3,08	2138	3700	27250			
			22	4,21	1568	3700	27250			
			18,5	5,00	1318	3700	27250			
	900	80	22	2,76	2547	3700	27250			
			18,5	3,28	2142	3700	27250			
			15	4,05	1737	3700	27250			
	700	65	18,5	2,60	2637	3700	27800			
			15	3,21	2138	3700	27800			
			11	4,38	1568	3700	27800			
	500	45	15	2,31	3088	3700	28350			
			11	3,15	2264	3700	28350			
			7,5	4,63	1544	3700	28350			





İ Tahvil Oranı Ratio Übersetzung	n ₁	n ₂	P ₁	S _f	M ₂	F _{q1}	F _{q2}	Tip Type Typ			kg
	Giriş Devri	Çıkış Devri	GÜÇ	Servis Faktörü	Çıkış Momenti	Rad. Yük	Rad. Yük				
	Input Speeds	Output Speeds	Power	Service Factor	Output Torque	Over Loads	Over Loads				
	Antriebswelle Drehzahlen	Abtriebswelle Drehzahlen	Leistung	Betriebsfaktor	Abtriebswelle Drehmomente	Querkräfte	Querkräfte				
	[r.p.m]	[r.p.m]	[kW]		[Nm]	[N]	[N]				
12.24	1400	115	30	2,82	2417	3700	27250				
			22	3,84	1772	3700	27250				
			18,5	4,57	1490	3700	27250				
	900	75	22	2,55	2717	3700	27250				
			18,5	3,03	2285	3700	27250				
			15	3,75	1853	3700	27250				
	700	60	18,5	2,37	2856	3700	27800				
			15	2,93	2316	3700	27800				
			11	4,00	1698	3700	27800				
	500	40	15	2,09	3474	3700	28350				
			11	2,86	2547	3700	28350				
			7,5	4,19	1737	3700	28350				
13.90	1400	100	30	2,58	2779	3700	27250				
			22	3,52	2038	3700	27250				
			18,5	4,19	1714	3700	27250				
	900	65	22	2,27	3135	3700	27800				
			18,5	2,70	2637	3700	27800				
			15	3,33	3138	3700	27800				
	700	50	18,5	2,14	3427	3700	27800				
			15	2,64	2779	3700	27800				
			11	3,61	2038	3700	27800				
	500	35	15	1,89	3970	3700	28350				
			11	2,58	2911	3700	28350				
			7,5	3,79	1985	3700	28350				
15.94	1400	90	30	2,31	3088	3700	27250	2A 200	659	215	
			22	3,15	2264	3700	27250				
			18,5	3,74	1904	3700	27250				
	900	55	22	2,04	3705	3700	27800				
			18,5	2,42	3116	3700	27800				
			15	3,00	2526	3700	27800				
	700	45	18,5	1,88	3808	3700	28350				
			15	2,32	3088	3700	28350				
			11	3,17	2264	3700	28350				
	500	30	15	1,66	4632	3700	28350				
			11	2,27	3397	3700	28350				
			7,5	3,33	2316	3700	28350				
17.16	1400	80	30	2,15	3474	3700	27250				
			22	2,93	2547	3700	27250				
			18,5	3,49	2142	3700	27250				
	900	50	22	1,90	4076	3700	27800				
			18,5	2,26	3427	3700	27800				
			15	2,79	2779	3700	27800				
	700	40	18,5	1,77	4284	3700	28350				
			15	2,18	3474	3700	28350				
			11	2,97	2547	3700	28350				
	500	30	15	1,58	4632	3700	28350				
			11	2,16	3397	3700	28350				
			7,5	3,33	2316	3700	28350				





İ Tahvil Oranı Ratio Übersetzung	n ₁	n ₂	P ₁	S _f	M ₂	F _{q1}	F _{q2}	Tip Type Typ			kg
	Giriş Devri	Çıkış Devri	GÜÇ	Servis Faktörü	Çıkış Momenti	Rad. Yük	Rad. Yük				
	Input Speeds	Output Speeds	Power	Service Factor	Output Torque	Over Loads	Over Loads				
	Antriebswelle Drehzahlen	Abtriebswelle Drehzahlen	Leistung	Betriebsfaktor	Abtriebswelle Drehmomente	Querkräfte	Querkräfte				
	[r.p.m]	[r.p.m]	[kW]		[Nm]	[N]	[N]				
18.53	1400	75	30	2,02	3705	3700	27250				
			22	2,75	2717	3700	27250				
			18,5	3,28	2285	3700	27250				
	900	50	22	1,76	4076	3700	27800				
			18,5	2,09	3427	3700	27800				
			15	2,58	2779	3700	27800				
	700	40	18,5	1,63	4284	3700	28350				
			15	2,01	3474	3700	28350				
			11	2,75	2547	3700	28350				
	500	25	15	1,47	5558	3700	29000				
			11	1,99	4076	3700	29000				
			7,5	2,92	2779	3700	29000				
20.11	1400	70	30	1,88	3970	3700	27250				
			22	2,56	2911	3700	27250				
			18,5	3,04	2448	3700	27250				
	900	45	22	1,64	4529	3700	28350				
			18,5	1,95	3808	3700	28350				
			15	2,41	3088	3700	28350				
	700	35	18,5	1,53	4896	3700	28350				
			15	1,90	3970	3700	28350				
			11	2,59	2911	3700	28350				
	500	25	15	1,35	5558	3700	29000				
			11	1,85	4076	3700	29000				
			7,5	2,71	2779	3700	29000				
21.52	1400	65	30	1,73	4275	3700	27800	2A 200	659	215	
			22	2,35	3135	3700	27800				
			18,5	2,80	2637	3700	27800				
	900	40	22	1,55	5095	3700	28350				
			18,5	1,83	4284	3700	28350				
			15	2,27	3474	3700	28350				
	700	30	18,5	1,42	5712	3700	28350				
			15	1,75	4632	3700	28350				
			11	2,39	3397	3700	28350				
	500	20	15	1,26	6948	3700	29000				
			11	1,72	5095	3700	29000				
			7,5	2,52	3474	3700	29000				
24.04	1400	60	30	1,58	4632	3700	27800				
			22	2,15	3397	3700	27800				
			18,5	2,56	2856	3700	27800				
	900	40	22	1,38	5095	3700	28350				
			18,5	1,63	4284	3700	28350				
			15	2,02	3474	3700	28350				
	700	30	18,5	1,28	5712	3700	28350				
			15	1,57	4632	3700	28350				
			11	2,15	3397	3700	28350				
	500	20	15	1,15	6948	3700	29000				
			11	1,57	5095	3700	29000				
			7,5	2,31	3474	3700	29000				





İ Tahvil Oranı Ratio Übersetzung	n ₁	n ₂	P ₁	S _f	M ₂	F _{q1}	F _{q2}	Tip Type Typ			kg
	Giriş Devri	Çıkış Devri	GÜÇ	Servis Faktörü	Çıkış Momenti	Rad. Yük	Rad. Yük				
	Input Speeds	Output Speeds	Power	Service Factor	Output Torque	Over Loads	Over Loads				
	Antriebswelle Drehzahlen	Abtriebswelle Drehzahlen	Leistung	Betriebsfaktor	Abtriebswelle Drehmomente	Querkräfte	Querkräfte				
	[r.p.m]	[r.p.m]	[kW]		[Nm]	[N]	[N]				
6.98	1400	200	11	1,45	509	2850	7600	2A 180	660	58	
			7,5	2,15	347	2850	7600				
			5,5	2,95	255	2850	7600				
	900	130	7,5	1,35	534	2850	7600				
			5,5	1,87	392	2850	7600				
			4	2,60	285	2850	7600				
	700	100	5,5	1,45	509	2850	7850				
			4	2,00	371	2850	7850				
			3	2,70	278	2850	7850				
	500	72	4	1,42	515	2850	8000				
			3	1,91	386	2850	8000				
			2,2	2,63	283	2850	8000				
9.51	1400	150	11	1,52	679	2850	7600				
			7,5	2,95	463	2850	7600				
			5,5	3,09	340	2850	7600				
	900	95	7,5	1,43	731	2850	8000				
			5,5	1,98	536	2850	8000				
			4	2,72	390	2850	8000				
	700	75	5,5	1,51	679	2850	8000				
			4	2,10	494	2850	8000				
			3	2,84	371	2850	8000				
	500	50	4	1,49	741	2850	8350				
			3	2,00	556	2850	8350				
			2,2	2,50	408	2850	8350				
11.75	1400	120	7,5	1,85	579	2850	7850				
			5,5	1,55	425	2850	7850				
			4	3,51	309	2850	7850				
	900	75	5,5	1,61	679	2850	8000				
			4	2,24	494	2850	8000				
			3	3,00	371	2850	8000				
	700	60	4	1,73	618	2850	8350				
			3	2,32	463	2850	8350				
			2,2	3,18	340	2850	8350				
	500	40	3	1,64	695	2850	8600				
			2,2	2,25	509	2850	8600				
			1,5	3,34	347	2850	8600				
14.88	1400	95	7,5	1,55	731	2850	8000				
			5,5	2,14	536	2850	8000				
			4	2,97	390	2850	8000				
	900	60	5,5	1,35	849	2850	8350				
			4	1,89	618	2850	8350				
			3	2,53	463	2850	8350				
	700	50	4	1,45	741	2850	8350				
			3	1,96	556	2850	8350				
			2,2	2,69	408	2850	8350				
	500	35	3	1,38	794	2850	8600				
			2,2	1,90	582	2850	8600				
			1,5	2,82	397	2850	8600				





İ Tahvil Oranı Ratio Übersetzung	n ₁	n ₂	P ₁	S _f	M ₂	F _{q1}	F _{qv2}	Tip Type Typ			kg
	Giriş Devri	Çıkış Devri	GÜÇ	Servis Faktörü	Çıkış Momenti	Rad. Yük	Rad. Yük				
	Input Speeds	Output Speeds	Power	Service Factor	Output Torque	Over Loads	Over Loads				
	Antriebswelle Drehzahlen	Abtriebswelle Drehzahlen	Leistung	Betriebsfaktor	Abtriebswelle Drehmomente	Querkräfte	Querkräfte				
	[r.p.m]	[r.p.m]	[kW]		[Nm]	[N]	[N]				
16.62	1400	85	5,5	1,82	599	2850	8000	2A 180	660	58	
			4	2,52	436	2850	8000				
			3	3,37	327	2850	8000				
	900	55	4	1,60	674	2850	8350				
			3	2,15	505	2850	8350				
			2,2	2,95	371	2850	8350				
	700	40	3	1,66	695	2850	8600				
			2,2	2,29	509	2850	8600				
			1,5	3,37	347	2850	8600				
	500	30	2,2	1,62	679	2850	8600				
			1,5	2,40	463	2850	8600				
			1,1	3,29	340	2850	8600				
18.15	1400	80	5,5	1,65	637	2850	8000				
			4	2,28	463	2850	8000				
			3	3,05	347	2850	8000				
	900	50	4	1,45	741	2850	8350				
			3	1,95	556	2850	8350				
			2,2	2,68	408	2850	8350				
	700	40	3	1,51	695	2850	8600				
			2,2	2,08	509	2850	8600				
			1,5	3,08	347	2850	8600				
	500	30	2,2	1,46	679	2850	8600				
			1,5	2,18	463	2850	8600				
			1,1	2,98	340	2850	8600				
20.01	1400	70	4	2,08	529	2850	8350				
			3	2,79	397	2850	8350				
			2,2	3,82	291	2850	8350				
	900	45	3	1,77	618	2850	8600				
			2,2	2,43	453	2850	8600				
			1,5	3,59	309	2850	8600				
	700	35	2,2	1,88	582	2850	8600				
			1,5	2,78	397	2850	8600				
			1,1	3,81	291	2850	8600				
	500	25	1,5	1,97	556	2850	8900				
			1,1	2,70	408	2850	8900				
			0,75	3,99	278	2850	8900				
23.75	1400	60	4	1,75	618	2850	8350				
			3	2,35	463	2850	8350				
			2,2	3,22	340	2850	8350				
	900	40	3	1,49	695	2850	8600				
			2,2	2,05	509	2850	8600				
			1,5	3,00	347	2850	8600				
	700	30	2,2	1,58	679	2850	8600				
			1,5	2,35	463	2850	8600				
			1,1	3,82	340	2850	8600				
	500	20	1,5	1,66	695	2850	8900				
			1,1	2,29	509	2850	8900				
			0,75	3,38	347	2850	8900				





İ Tahvil Oranı Ratio Übersetzung	n ₁	n ₂	P ₁	S _f	M ₂	F _{q1}	F _{qv2}	Tip Type Typ			kg
	Giriş Devri	Çıkış Devri	GÜÇ	Servis Faktörü	Çıkış Momenti	Rad. Yük	Rad. Yük				
	Input Speeds	Output Speeds	Power	Service Factor	Output Torque	Over Loads	Over Loads				
	Antriebswelle Drehzahlen	Abtriebswelle Drehzahlen	Leistung	Betriebsfaktor	Abtriebswelle Drehmomente	Querkräfte	Querkräfte				
	[r.p.m]	[r.p.m]	[kW]		[Nm]	[N]	[N]				
30.80	1400	45	3	1,75	618	2850	8600	2A 180	660	58	
			2,2	2,40	453	2850	8600				
			1,5	3,55	309	2850	8600				
	900	30	2,2	1,52	679	2850	8600				
			1,5	2,25	463	2850	8600				
			1,1	3,10	340	2850	8600				
	700	23	1,5	1,74	604	2850	8900				
			1,1	2,40	443	2850	8900				
			0,75	3,54	302	2850	8900				
	500	16	1,1	1,70	637	2850	8900				
			0,75	2,51	434	2850	8900				
			0,55	3,45	318	2850	8900				
35.78	1400	40	2,2	2,06	509	2850	8600				
			1,5	3,04	347	2850	8600				
			1,1	4,17	255	2850	8600				
	900	25	1,5	1,94	556	2850	8900				
			1,1	2,67	408	2850	8900				
			0,75	3,93	278	2850	8900				
	700	20	1,1	2,05	509	2850	8900				
			0,75	3,03	347	2850	8900				
			0,55	4,16	255	2850	8900				
	500	14	0,75	2,15	496	2850	8900				
			0,55	2,95	364	2850	8900				
			0,37	2,40	245	2850	8900				
38.80	1400	35	2,2	1,92	582	2850	8600				
			1,5	2,83	397	2850	8600				
			1,1	3,89	291	2850	8600				
	900	23	1,5	1,80	604	2850	8900				
			1,1	2,48	443	2850	8900				
			0,75	3,66	302	2850	8900				
	700	18	1,1	1,91	566	2850	8900				
			0,75	2,83	386	2850	8900				
			0,55	2,88	283	2850	8900				
	500	13	0,75	2,01	534	2850	8900				
			0,55	2,76	392	2850	8900				
			0,37	4,13	264	2850	8900				
46.02	1400	30	2,2	1,30	679	2850	8600				
			1,5	1,93	463	2850	8600				
			1,1	2,65	340	2850	8600				
	900	20	1,5	1,22	695	2850	8900				
			1,1	1,69	509	2850	8900				
			0,75	2,50	347	2850	8900				
	700	15	1,1	1,30	679	2850	8900				
			0,75	1,93	463	2850	8900				
			0,55	2,65	340	2850	8900				
	500	11	0,75	1,35	632	2850	8900				
			0,55	1,86	463	2850	8900				
			0,37	2,80	312	2850	8900				





İ Tahvil Oranı Ratio Übersetzung	n ₁	n ₂	P ₁	S _f	M ₂	F _{q1}	F _{qv2}	Tip Type Typ			kg
	Giriş Devri	Çıkış Devri	GÜÇ	Servis Faktörü	Çıkış Momenti	Rad. Yük	Rad. Yük				
	Input Speeds	Output Speeds	Power	Service Factor	Output Torque	Over Loads	Over Loads				
	Antriebswelle Drehzahlen	Abtriebswelle Drehzahlen	Leistung	Betriebsfaktor	Abtriebswelle Drehmomente	Querkräfte	Querkräfte				
[r.p.m]	[r.p.m]	[kW]		[Nm]	[N]	[N]					
7.32	1400	190	22	1,95	1073	3550	8250				
			18,5	2,32	902	3550	8250				
			15	2,88	731	3550	8250				
	900	120	18,5	1,45	1428	3550	8250				
			15	1,83	1158	3550	8250				
			11	2,52	849	3550	8250				
	700	95	15	1,41	1463	3550	8500				
			11	1,95	1073	3550	8500				
			7,5	2,88	731	3550	8500				
	500	70	11	1,38	1456	3550	8900				
			7,5	2,03	993	3550	8900				
			5,5	2,80	728	3550	8900				
10.52	1400	133	22	1,85	1532	3550	8250				
			18,5	2,21	1289	3550	8250				
			15	2,73	1045	3550	8250				
	900	85	18,5	1,40	2016	3550	8800				
			15	1,73	1635	3550	8800				
			11	2,38	1199	3550	8800				
	700	65	15	1,34	2138	3550	9000				
			11	1,84	1568	3550	9000				
			7,5	2,73	1069	3550	9000				
	500	45	11	1,31	2264	3550	9280				
			7,5	1,94	1544	3550	9280				
			5,5	2,67	1132	3550	9280				
11.04	1400	125	18,5	1,35	1371	3550	8250	2A 2AE	225	661 671	94 134
			15	1,68	1112	3550	8250				
			11	2,30	815	3550	8250				
	900	80	15	1,05	1737	3550	8800				
			11	1,46	1274	3550	8800				
			7,5	2,17	868	3550	8800				
	700	63	11	1,13	1617	3550	9000				
			7,5	1,68	1103	3550	9000				
			5,5	2,30	809	3550	9000				
	500	45	7,5	1,18	1544	3550	9280				
			5,5	1,63	1132	3550	9280				
			4	2,25	823	3550	9280				
14.12	1400	100	15	1,55	1390	3550	8500				
			11	2,13	1019	3550	8500				
			7,5	3,15	695	3550	8500				
	900	65	11	1,35	1568	3550	9000				
			7,5	2,00	1069	3550	9000				
			5,5	2,50	784	3550	9000				
	700	50	7,5	1,54	1390	3550	9000				
			5,5	2,13	1019	3550	9000				
			4	2,92	741	3550	9000				
	500	35	5,5	1,50	1456	3550	9280				
			4	2,19	1059	3550	9280				
			3	2,80	794	3550	9280				





İ Tahvil Oranı Ratio Übersetzung	n ₁	n ₂	P ₁	S _f	M ₂	F _{q1}	F _{qv2}	Tip Type Typ			kg
	Giriş Devri	Çıkış Devri	GÜÇ	Servis Faktörü	Çıkış Momenti	Rad. Yük	Rad. Yük				
	Input Speeds	Output Speeds	Power	Service Factor	Output Torque	Over Loads	Over Loads				
	Antriebswelle Drehzahlen	Abtriebswelle Drehzahlen	Leistung	Betriebsfaktor	Abtriebswelle Drehmomente	Querkräfte	Querkräfte				
	[r.p.m]	[r.p.m]	[kW]		[Nm]	[N]	[N]				
15.60	1400	90	11	2,15	1132	3550	8800	2A 2AE 225	661	94	
			7,5	3,17	772	3550	8800				
			5,5	4,35	566	3550	8800				
	900	60	7,5	2,00	1158	3550	9000				
			5,5	2,78	849	3550	9000				
			4	3,78	618	3550	9000				
	700	45	5,5	2,14	1132	3550	9280				
			4	2,95	823	3550	9280				
			3	3,92	618	3550	9280				
	500	32	4	2,11	1158	3550	9280				
			3	2,83	868	3550	9280				
			2,2	2,89	637	3550	9280				
17.30	1400	80	11	1,80	1274	3550	8800				
			7,5	2,66	868	3550	8800				
			5,5	3,65	637	3550	8800				
	900	50	7,5	1,68	1390	3550	9000				
			5,5	2,33	1019	3550	9000				
			4	3,22	741	3550	9000				
	700	40	5,5	1,80	1274	3550	9280				
			4	2,49	926	3550	9280				
			3	3,33	695	3550	9280				
	500	30	4	1,76	1235	3550	9280				
			3	2,37	926	3550	9280				
			2,2	3,25	679	3550	9280				
21.25	1400	65	7,5	2,70	1069	3550	9000				
			5,5	3,70	784	3550	9000				
			4	5,10	570	3550	9000				
	900	42	5,5	2,35	1213	3550	9280				
			4	3,26	882	3550	9280				
			3	4,36	662	3550	9280				
	700	33	4	2,52	1123	3550	9280				
			3	3,38	842	3550	9280				
			2,2	4,63	618	3550	9280				
	500	24	3	2,40	1158	3550	9600				
			2,2	3,39	849	3550	9600				
			1,5	4,84	579	3550	9600				
24.14	1400	60	7,5	2,15	1158	3550	9000				
			5,5	2,95	849	3550	9000				
			4	4,17	618	3550	9000				
	900	37	5,5	1,88	1377	3550	9280				
			4	2,60	1001	3550	9280				
			3	3,49	751	3550	9280				
	700	29	4	2,00	1278	3550	9600				
			3	2,69	958	3550	9600				
			2,2	3,69	703	3550	9600				
	500	21	3	1,91	1323	3550	9600				
			2,2	2,63	970	3550	9600				
			1,5	3,88	662	3550	9600				





İ Tahvil Oranı Ratio Übersetzung	n ₁	n ₂	P ₁	S _f	M ₂	F _{q1}	F _{q2}	Tip Type Typ			kg
	Giriş Devri	Çıkış Devri	GÜÇ	Servis Faktörü	Çıkış Momenti	Rad. Yük	Rad. Yük				
	Input Speeds	Output Speeds	Power	Service Factor	Output Torque	Over Loads	Over Loads				
	Antriebswelle Drehzahlen	Abtriebswelle Drehzahlen	Leistung	Betriebsfaktor	Abtriebswelle Drehmomente	Querkräfte	Querkräfte				
	[r.p.m]	[r.p.m]	[kW]		[Nm]	[N]	[N]				
32.12	1400	45	7,5	1,75	1544	3550	9280				
			5,5	2,40	1132	3550	9280				
			4	3,32	823	3550	9280				
	900	28	5,5	1,45	1820	3550	9600				
			4	2,02	1323	3550	9600				
			3	2,71	993	3550	9600				
	700	22	4	1,55	1684	3550	9600				
			3	2,10	1263	3550	9600				
			2,2	2,88	926	3550	9600				
	500	16	3	1,48	1737	3550	9600				
			2,2	2,05	1274	3550	9600				
			1,5	3,02	868	3550	9600				
35.79	1400	40	7,5	1,29	1737	3550	9280				
			5,5	1,77	1274	3550	9280				
			4	2,46	926	3550	9280				
	900	25	5,5	1,12	2038	3550	9600				
			4	1,56	1482	3550	9600				
			3	2,10	1112	3550	9600				
	700	20	4	1,21	1853	3550	9600				
			3	1,63	1390	3550	9600				
			2,2	2,23	1019	3550	9600				
	500	14	3	1,14	1985	3550	9600				
			2,2	1,57	1456	3550	9600				
			1,5	2,38	993	3550	9600				
38.92	1400	36	5,5	1,55	1415	3550	9280	2A 2AE 225	661	94	
			4	2,15	1029	3550	9280				
			3	2,88	772	3550	9280				
	900	23	4	1,36	1611	3550	9600				
			3	1,83	1208	3550	9600				
			2,2	2,52	886	3550	9600				
	700	18	3	1,41	1544	3550	9600				
			2,2	1,94	1132	3550	9600				
			1,5	2,87	772	3550	9600				
	500	13	2,2	1,37	1568	3550	9600				
			1,5	2,04	1069	3550	9600				
			1,1	2,80	784	3550	9600				
46.69	1400	30	4	1,65	1235	3550	9280				
			3	2,21	926	3550	9280				
			2,2	3,04	679	3550	9280				
	900	19	3	1,41	1463	3550	9600				
			2,2	1,94	1073	3550	9600				
			1,5	2,87	731	3550	9600				
	700	15	2,2	1,49	1073	3550	9600				
			1,5	2,20	731	3550	9600				
			1,1	3,03	536	3550	9600				
	500	11	1,5	1,57	1263	3550	9600				
			1,1	2,16	926	3550	9600				
			0,75	3,19	632	3550	9600				





İ Tahvil Oranı Ratio Übersetzung	n ₁	n ₂	P ₁	S _f	M ₂	F _{q1}	F _{q2}	Tip Type Typ			kg
	Giriş Devri	Çıkış Devri	GÜÇ	Servis Faktörü	Çıkış Momenti	Rad. Yük	Rad. Yük				
	Input Speeds	Output Speeds	Power	Service Factor	Output Torque	Over Loads	Over Loads				
	Antriebswelle Drehzahlen	Abtriebswelle Drehzahlen	Leistung	Betriebsfaktor	Abtriebswelle Drehmomente	Querkräfte	Querkräfte				
	[r.p.m]	[r.p.m]	[kW]		[Nm]	[N]	[N]				
6.26	1400	220	45	2,66	1895	4800	17500				
			37	3,24	1558	4800	17500				
			30	4,00	1263	4800	17500				
	900	144	37	2,13	2380	4800	17500				
			30	2,63	1930	4800	17500				
			22	3,58	1415	4800	17500				
	700	112	30	2,03	2481	4800	18250				
			22	2,78	1820	4800	18250				
			18,5	3,30	1530	4800	18250				
	500	80	22	1,98	2547	4800	19000				
			18,5	2,36	2142	4800	19000				
			15	2,91	1737	4800	19000				
7.83	1400	180	45	2,18	2316	4800	17500				
			37	2,65	1904	4800	17500				
			30	3,27	1544	4800	17500				
	900	115	37	1,70	2980	4800	18250				
			30	2,10	2417	4800	18250				
			22	2,86	1772	4800	18250				
	700	90	30	1,63	3088	4800	19000				
			22	2,23	2264	4800	19000				
			18,5	2,65	1904	4800	19000				
	500	64	22	1,59	3184	4800	19650				
			18,5	1,89	2678	4800	19650				
			15	2,33	2171	4800	19650				
9.69	1400	145	45	1,68	2875	4800	17500	2A 2AE 275	662 672	153 205	
			37	2,05	2364	4800	17500				
			30	2,52	1917	4800	17500				
	900	93	37	1,31	3685	4800	19000				
			30	1,62	2988	4800	19000				
			22	2,21	2191	4800	19000				
	700	72	30	1,26	3860	4800	19000				
			22	1,71	2831	4800	19000				
			18,5	2,04	2380	4800	19000				
	500	52	22	1,22	3919	4800	19650				
			18,5	1,46	3296	4800	19650				
			15	1,80	2672	4800	19650				
11.79	1400	120	37	1,82	2856	4800	18250				
			30	2,24	2316	4800	18250				
			22	3,06	1698	4800	18250				
	900	76	30	1,44	3657	4800	19000				
			22	1,96	2682	4800	19000				
			18,5	2,34	2255	4800	19000				
	700	60	22	1,53	3397	4800	19650				
			18,5	1,81	2856	4800	19650				
			15	2,24	2316	4800	19650				
	500	42	18,5	1,30	4080	4800	20400				
			15	1,60	3308	4800	20400				
			11	2,18	2426	4800	20400				





İ Tahvil Oranı Ratio Übersetzung	n ₁	n ₂	P ₁	S _f	M ₂	F _{q1}	F _{qv2}	Tip Type Typ			kg
	Giriş Devri	Çıkış Devri	GÜÇ	Servis Faktörü	Çıkış Momenti	Rad. Yük	Rad. Yük				
	Input Speeds	Output Speeds	Power	Service Factor	Output Torque	Over Loads	Over Loads				
	Antriebswelle Drehzahlen	Abtriebswelle Drehzahlen	Leistung	Betriebsfaktor	Abtriebswelle Drehmomente	Querkräfte	Querkräfte				
	[r.p.m]	[r.p.m]	[kW]		[Nm]	[N]	[N]				
14.29	1400	98	37	1,46	3497	4800	19000	2A 2AE 275	662	153	
			30	1,80	2836	4800	19000				
			22	2,45	2080	4800	19000				
	900	63	30	1,15	4411	4800	19650				
			22	1,57	3235	4800	19650				
			18,5	1,87	2720	4800	19650				
	700	50	22	1,22	4076	4800	19650				
			18,5	1,45	3427	4800	19650				
			15	1,80	2779	4800	19650				
	500	35	18,5	1,04	4896	4800	20400				
			15	1,28	3970	4800	20400				
			11	1,75	2911	4800	20400				
17.96	1400	78	30	1,46	3569	4800	19000				
			22	1,99	2613	4800	19000				
			18,5	2,36	2197	4800	19000				
	900	50	22	1,28	4076	4800	19650				
			18,5	1,52	3427	4800	19650				
			15	1,87	2779	4800	19650				
	700	40	18,5	1,18	4284	4800	20400				
			15	1,45	3474	4800	20400				
			11	1,98	2547	4800	20400				
	500	28	15	1,04	4963	4800	21000				
			11	1,42	3639	4800	21000				
			7,5	2,08	2481	4800	21000				
20.00	1400	70	30	1,58	3970	4800	19000				
			22	2,15	2911	4800	19000				
			18,5	2,56	2448	4800	19000				
	900	45	22	1,38	4529	4800	20400				
			18,5	1,64	3808	4800	20400				
			15	2,03	3088	4800	20400				
	700	34	18,5	1,28	5040	4800	20400				
			15	1,58	4087	4800	20400				
			11	2,15	2997	4800	20400				
	500	25	15	1,12	5558	4800	21000				
			11	1,53	4076	4800	21000				
			7,5	2,25	2779	4800	21000				
23.77	1400	58	22	1,55	3514	4800	19650				
			18,5	1,84	2955	4800	19650				
			15	2,27	2396	4800	19650				
	900	37	18,5	1,18	4632	4800	20400				
			15	1,46	3755	4800	20400				
			11	1,99	2754	4800	20400				
	700	29	15	1,13	4791	4800	21000				
			11	1,54	3514	4800	21000				
			7,5	2,27	2396	4800	21000				
	500	21	11	1,11	4852	4800	21000				
			7,5	1,62	3308	4800	21000				
			5,5	2,21	2426	4800	21000				





İ Tahvil Oranı Ratio Übersetzung	n ₁	n ₂	P ₁	S _f	M ₂	F _{q1}	F _{q2}	Tip Type Typ			kg
	Giriş Devri	Çıkış Devri	GÜÇ	Servis Faktörü	Çıkış Momenti	Rad. Yük	Rad. Yük				
	Input Speeds	Output Speeds	Power	Service Factor	Output Torque	Over Loads	Over Loads				
	Antriebswelle Drehzahlen	Abtriebswelle Drehzahlen	Leistung	Betriebsfaktor	Abtriebswelle Drehmomente	Querkräfte	Querkräfte				
[r.p.m]	[r.p.m]	[kW]		[Nm]	[N]	[N]					
29.25	1400	48	15	1,62	2895	4800	20400	2A 2AE			
			11	2,21	2123	4800	20400				
			7,5	3,25	1447	4800	20400				
	900	30	11	1,42	3397	4800	20400				
			7,5	2,08	2316	4800	20400				
			5,5	2,83	1698	4800	20400				
	700	24	7,5	1,62	2895	4800	21000				
			5,5	2,21	2123	4800	21000				
			4	3,03	1544	4800	21000				
	500	17	5,5	1,58	2997	4800	21000				
			4	2,17	2180	4800	21000				
			3	2,89	1635	4800	21000				
37.91	1400	37	15	1,12	3755	4800	20400	2A 2AE	275	662	153
			11	1,52	2754	4800	20400				
			7,5	2,23	1878	4800	20400				
	900	24	11	0,98	4246	4800	21000				
			7,5	1,43	2895	4800	21000				
			5,5	1,96	2123	4800	21000				
	700	19	7,5	1,12	3657	4800	21000				
			5,5	1,53	2682	4800	21000				
			4	2,10	1950	4800	21000				
	500	13	5,5	1,09	3919	4800	21000				
			4	1,50	2850	4800	21000				
			3	2,00	2138	4800	21000				
47.50	1400	30	11	1,21	3397	4800	20400				
			7,5	1,77	2316	4800	20400				
			5,5	2,42	1698	4800	20400				
	900	19	7,5	1,14	3657	4800	21000				
			5,5	1,55	2682	4800	21000				
			4	2,13	1950	4800	21000				
	700	15	5,5	1,20	3397	4800	21000				
			4	1,65	2470	4800	21000				
			3	2,21	1853	4800	21000				
	500	10	4	1,18	3705	4800	21000				
			3	1,58	2779	4800	21000				
			2,2	2,15	2038	4800	21000				
6.50	1400	215	75	2,28	3231	8300	22300	2A 2AE	350	663	287
			55	3,12	2370	8300	22300				
			45	3,81	1939	8300	22300				
	900	140	55	1,99	3639	8300	22300				
			45	2,44	2978	8300	22300				
			37	2,97	2448	8300	22300				
	700	108	45	1,89	3860	8300	25500				
			37	2,30	3174	8300	25500				
			30	2,84	2573	8300	25500				
	500	77	37	1,65	4451	8300	25750				
			30	2,03	3609	8300	25750				
			22	2,77	2647	8300	25750				





İ Tahvil Oranı Ratio Übersetzung	n ₁	n ₂	P ₁	S _f	M ₂	F _{q1}	F _{qv2}	Tip Type Typ			kg
	Giriş Devri	Çıkış Devri	GÜÇ	Servis Faktörü	Çıkış Momenti	Rad. Yük	Rad. Yük				
	Input Speeds	Output Speeds	Power	Service Factor	Output Torque	Over Loads	Over Loads				
	Antriebswelle Drehzahlen	Abtriebswelle Drehzahlen	Leistung	Betriebsfaktor	Abtriebswelle Drehmomente	Querkräfte	Querkräfte				
	[r.p.m]	[r.p.m]	[kW]		[Nm]	[N]	[N]				
10.03	1400	140	75	2,18	4963	8300	22300				
			55	2,98	3639	8300	22300				
			45	3,64	2978	8300	22300				
	900	90	55	1,91	5661	8300	25750				
			45	2,33	4632	8300	25750				
			37	2,84	3808	8300	25750				
	700	70	45	1,81	5955	8300	25750				
			37	2,21	4896	8300	25750				
			30	2,72	3970	8300	25750				
	500	50	37	1,57	6855	8300	26250				
			30	1,94	5558	8300	26250				
			22	2,65	4076	8300	26250				
14.38	1400	97	55	2,04	5253	8300	25750				
			45	2,49	4298	8300	25750				
			37	3,03	3534	8300	25750				
	900	63	45	1,60	6617	8300	26250				
			37	1,95	5440	8300	26250				
			30	2,40	4411	8300	26250				
	700	50	37	1,51	6855	8300	26250				
			30	1,86	5558	8300	26250				
			22	2,55	4076	8300	26250				
	500	35	30	1,33	7940	8300	27000				
			22	1,81	5823	8300	27000				
			18,5	2,16	4896	8300	27000				
16.04	1400	90	55	1,91	5661	8300	25750	2A 2AE 350	663 673	287 342	
			45	2,33	4632	8300	25750				
			37	2,84	3808	8300	25750				
	900	56	45	1,50	7444	8300	26250				
			37	1,82	6121	8300	26250				
			30	2,25	4963	8300	26250				
	700	44	37	1,41	7790	8300	27000				
			30	1,75	6316	8300	27000				
			22	2,38	4632	8300	27000				
	500	31	30	1,25	8965	8300	27000				
			22	1,70	6574	8300	27000				
			18,5	2,03	5528	8300	27000				
20.08	1400	70	45	1,83	5955	8300	25750				
			37	2,23	4896	8300	25750				
			30	2,75	3970	8300	25750				
	900	45	37	1,43	7617	8300	27000				
			30	1,76	6176	8300	27000				
			22	2,41	4529	8300	27000				
	700	35	30	1,37	7940	8300	27000				
			22	1,86	5823	8300	27000				
			18,5	2,22	4896	8300	27000				
	500	25	22	1,33	8152	8300	27500				
			18,5	1,59	6855	8300	27500				
			15	1,96	5558	8300	27500				





İ Tahvil Oranı Ratio Übersetzung	n ₁	n ₂	P ₁	S _f	M ₂	F _{q1}	F _{qv2}	Tip Type Typ			kg
	Giriş Devri	Çıkış Devri	GÜÇ	Servis Faktörü	Çıkış Momenti	Rad. Yük	Rad. Yük				
	Input Speeds	Output Speeds	Power	Service Factor	Output Torque	Over Loads	Over Loads				
	Antriebswelle Drehzahlen	Abtriebswelle Drehzahlen	Leistung	Betriebsfaktor	Abtriebswelle Drehmomente	Querkräfte	Querkräfte				
	[r.p.m]	[r.p.m]	[kW]		[Nm]	[N]	[N]				
23.41	1400	60	37	1,45	5712	8300	26250	2A 2AE 350	663	287	342
			30	1,78	4632	8300	26250				
			22	2,44	3397	8300	26250				
	900	38	30	1,15	7313	8300	27000				
			22	1,56	5363	8300	27000				
			18,5	1,86	4510	8300	27000				
	700	30	22	1,22	6793	8300	27000				
			18,5	1,45	5712	8300	27000				
			15	1,78	4632	8300	27000				
	500	21	18,5	1,04	8161	8300	27500				
			15	1,28	6617	8300	27500				
			11	1,74	4862	8300	27500				
31.50	1400	44	30	1,69	6316	8300	27000				
			22	2,30	4632	8300	27000				
			18,5	2,74	3895	8300	27000				
	900	28	22	1,48	7278	8300	27500				
			18,5	1,76	6121	8300	27500				
			15	2,17	4963	8300	27500				
	700	22	18,5	1,37	7790	8300	27500				
			15	1,69	6316	8300	27500				
			11	2,30	4632	8300	27500				
	500	16	15	1,21	8685	8300	27500				
			11	1,65	6369	8300	27500				
			7,5	2,42	4342	8300	27500				
35.00	1400	40	22	1,93	5095	8300	27000				
			18,5	2,29	4284	8300	27000				
			15	2,83	3474	8300	27000				
	900	26	18,5	1,47	6591	8300	27500				
			15	1,82	5344	8300	27500				
			11	2,48	3919	8300	27500				
	700	20	15	1,41	6948	8300	27500				
			11	1,93	5095	8300	27500				
			7,5	2,83	3474	8300	27500				
	500	14	11	1,38	7278	8300	27500				
			7,5	2,02	4963	8300	27500				
			5,5	2,76	3639	8300	27500				
48.97	1400	29	18,5	1,35	5909	8300	27500				
			15	1,67	4791	8300	27500				
			11	2,21	3514	8300	27500				
	900	18	15	1,07	7720	8300	27500				
			11	1,46	5661	8300	27500				
			7,5	2,14	3860	8300	27500				
	700	14	11	1,13	7278	8300	27500				
			7,5	1,66	4963	8300	27500				
			5,5	2,27	3639	8300	27500				
	500	10	7,5	1,18	6948	8300	27500				
			5,5	1,62	5095	8300	27500				
			4	2,22	3705	8300	27500				





İ Tahvil Oranı Ratio Übersetzung	n ₁	n ₂	P ₁	S _f	M ₂	F _{q1}	F _{q2}	Tip Type Typ			kg
	Giriş Devri	Çıkış Devri	GÜÇ	Servis Faktörü	Çıkış Momenti	Rad. Yük	Rad. Yük				
	Input Speeds	Output Speeds	Power	Service Factor	Output Torque	Over Loads	Over Loads				
	Antriebswelle Drehzahlen	Abtriebswelle Drehzahlen	Leistung	Betriebsfaktor	Abtriebswelle Drehmomente	Querkräfte	Querkräfte				
	[r.p.m]	[r.p.m]	[kW]		[Nm]	[N]	[N]				
6.18	1400	227	160	3,30	6529	8550	60000	2A 2AE 430	664	535	
			132	4,00	5387	8550	60000				
			110	4,80	4489	8550	60000				
	900	145	132	2,57	8433	8550	60000				
			110	3,08	7027	8550	60000				
			90	3,77	5750	8550	60000				
	700	113	110	2,40	9018	8550	61500				
			90	2,93	7378	8550	61500				
			75	3,52	6148	8550	61500				
	500	81	90	2,09	10293	8550	63000				
			75	2,51	8577	8550	63000				
			55	3,43	6290	8550	63000				
7.04	1400	200	160	2,88	7411	8550	60000				
			132	3,49	6114	8550	60000				
			110	4,19	5095	8550	60000				
	900	130	132	2,24	9406	8550	61500				
			110	2,69	7838	8550	61500				
			90	3,29	6413	8550	61500				
	700	100	110	2,09	10190	8550	63000				
			90	2,56	8337	8550	63000				
			75	3,07	6948	8550	63000				
	500	71	90	1,82	11742	8550	63000				
			75	2,19	9785	8550	63000				
			55	2,99	7176	8550	63000				
8.07	1400	174	160	2,51	8518	8550	60000				
			132	3,04	7027	8550	60000				
			110	3,65	5856	8550	60000				
	900	112	132	1,95	10918	8550	63000				
			110	2,35	9098	8550	63000				
			90	2,87	7444	8550	63000				
	700	87	110	1,82	11712	8550	63000				
			90	2,23	9583	8550	63000				
			75	2,67	7986	8550	63000				
	500	62	90	1,59	13447	8550	64500				
			75	1,91	11206	8550	64500				
			55	2,60	8218	8550	64500				
9.32	1400	150	160	2,17	9881	8550	60000				
			132	2,63	8152	8550	60000				
			110	3,16	6793	8550	60000				
	900	97	132	1,69	12606	8550	63000				
			110	2,03	10505	8550	63000				
			90	2,48	8595	8550	63000				
	700	75	110	1,57	13586	8550	63000				
			90	1,92	11116	8550	63000				
			75	2,31	9264	8550	63000				
	500	54	90	1,37	15439	8550	64500				
			75	1,65	12866	8550	64500				
			55	2,25	9435	8550	64500				





İ Tahvil Oranı Ratio Übersetzung	n ₁	n ₂	P ₁	S _f	M ₂	F _{q1}	F _{q2}	Tip Type Typ			kg
	Giriş Devri	Çıkış Devri	GÜÇ	Servis Faktörü	Çıkış Momenti	Rad. Yük	Rad. Yük				
	Input Speeds	Output Speeds	Power	Service Factor	Output Torque	Over Loads	Over Loads				
	Antriebswelle Drehzahlen	Abtriebswelle Drehzahlen	Leistung	Betriebsfaktor	Abtriebswelle Drehmomente	Querkräfte	Querkräfte				
	[r.p.m]	[r.p.m]	[kW]		[Nm]	[N]	[N]				
10.86	1400	130	132	2,27	9406	8550	61500				
			110	2,73	7838	8550	61500				
			90	3,33	6413	8550	61500				
	900	83	110	1,75	12277	8550	63000				
			90	2,14	10045	8550	63000				
			75	2,57	8371	8550	63000				
	700	64	90	1,66	13027	8550	64500				
			75	1,99	10856	8550	64500				
			55	2,72	7961	8550	64500				
	500	46	75	1,42	15104	8550	68000				
			55	1,94	11076	8550	68000				
			45	2,37	9062	8550	68000				
12.81	1400	109	132	1,96	11218	8550	63000	2A 2AE 430	664	535	
			110	2,35	9348	8550	63000				
			90	2,87	7649	8550	63000				
	900	70	110	1,51	14557	8550	63000				
			90	1,85	11910	8550	63000				
			75	2,22	9925	8550	63000				
	700	55	90	1,43	15158	8550	64500				
			75	1,72	12632	8550	64500				
			55	2,35	9264	8550	64500				
	500	39	75	1,23	17814	8550	68000				
			55	1,67	13064	8550	68000				
			45	2,05	10689	8550	68000				
15.36	1400	91	110	1,92	11198	8550	63000				
			90	2,34	9162	8550	63000				
			75	2,81	7635	8550	63000				
	900	59	90	1,51	14131	8550	64500				
			75	1,81	11776	8550	64500				
			55	2,47	8635	8550	64500				
	700	46	75	1,41	15104	8550	68000				
			55	1,92	11076	8550	68000				
			45	2,35	9062	8550	68000				
	500	33	55	1,37	15439	8550	68000				
			45	1,67	13632	8550	68000				
			37	2,03	10386	8550	68000				
16.96	1400	83	90	2,18	10045	8550	63000				
			75	2,62	8371	8550	63000				
			55	3,57	6138	8550	63000				
	900	53	75	1,68	13109	8550	64500				
			55	2,29	9613	8550	64500				
			45	2,80	7865	8550	64500				
	700	41	55	1,78	12427	8550	68000				
			45	2,18	10167	8550	68000				
			37	2,65	8360	8550	68000				
	500	30	45	1,55	13895	8550	68000				
			37	1,89	11425	8550	68000				
			30	2,38	9264	8550	68000				





İ Tahvil Oranı Ratio Übersetzung	n ₁	n ₂	P ₁	S _f	M ₂	F _{q1}	F _{qv2}	Tip Type Typ			kg
	Giriş Devri	Çıkış Devri	GÜÇ	Servis Faktörü	Çıkış Momenti	Rad. Yük	Rad. Yük				
	Input Speeds	Output Speeds	Power	Service Factor	Output Torque	Over Loads	Over Loads				
	Antriebswelle Drehzahlen	Abtriebswelle Drehzahlen	Leistung	Betriebsfaktor	Abtriebswelle Drehmomente	Querkräfte	Querkräfte				
	[r.p.m]	[r.p.m]	[kW]		[Nm]	[N]	[N]				
18.84	1400	74	90	1,98	11266	8550	63000	2A 2AE 430	664	535	
			75	2,38	9389	8550	63000				
			55	3,24	6885	8550	63000				
	900	48	75	1,52	14474	8550	68000				
			55	2,08	10614	8550	68000				
			45	2,54	8685	8550	68000				
	700	37	55	1,61	13770	8550	68000				
			45	1,98	11266	8550	68000				
			37	2,40	9264	8550	68000				
	500	27	45	1,41	15439	8550	70000				
			37	1,72	12694	8550	70000				
			30	2,11	10293	8550	70000				
23.18	1400	60	75	1,85	11579	8550	64500	2A 2AE 430	674	610	
			55	2,53	8492	8550	64500				
			45	3,09	6948	8550	64500				
	900	39	55	1,62	13064	8550	68000				
			45	1,98	10689	8550	68000				
			37	2,41	8788	8550	68000				
	700	30	45	1,54	13895	8550	68000				
			37	1,87	11425	8550	68000				
			30	2,31	9264	8550	68000				
	500	22	37	1,34	15580	8550	70000				
			30	1,65	12632	8550	70000				
			22	2,25	9264	8550	70000				
7.28	1400	192	160	2,11	7720	8900	76000	2A 2AE 501	665	800	
			132	2,56	6369	8900	76000				
			110	3,07	5307	8900	76000				
	900	124	132	1,64	9861	8900	76000				
			110	1,97	8218	8900	76000				
			90	2,41	6724	8900	76000				
	700	96	110	1,54	10614	8900	78000				
			90	1,87	8685	8900	78000				
			75	2,25	7237	8900	78000				
	500	69	90	1,34	12083	8900	81000				
			75	1,61	10069	8900	81000				
			55	2,19	7384	8900	81000				
10.48	1400	134	160	2,02	11061	8900	76000	2A 2AE 501	675	880	
			132	2,45	9125	8900	76000				
			110	2,95	7604	8900	76000				
	900	86	132	1,57	14218	8900	80000				
			110	1,88	11849	8900	80000				
			90	2,30	9694	8900	80000				
	700	67	110	1,47	15209	8900	81000				
			90	1,80	12444	8900	81000				
			75	2,15	10370	8900	81000				
	500	48	90	1,28	17369	8900	82500				
			75	1,53	14474	8900	82500				
			55	2,09	10614	8900	82500				





İ Tahvil Oranı Ratio Übersetzung	n ₁	n ₂	P ₁	S _f	M ₂	F _{q1}	F _{qv2}	Tip Type Typ			kg
	Giriş Devri	Çıkış Devri	GÜÇ	Servis Faktörü	Çıkış Momenti	Rad. Yük	Rad. Yük				
	Input Speeds	Output Speeds	Power	Service Factor	Output Torque	Over Loads	Over Loads				
	Antriebswelle Drehzahlen	Abtriebswelle Drehzahlen	Leistung	Betriebsfaktor	Abtriebswelle Drehmomente	Querkräfte	Querkräfte				
	[r.p.m]	[r.p.m]	[kW]		[Nm]	[N]	[N]				
12.89	1400	109	160	1,74	13598	8900	78000				
			132	2,10	11218	8900	78000				
			110	2,52	9348	8900	78000				
	900	70	132	1,35	17468	8900	80000				
			110	1,63	14557	8900	80000				
			90	1,99	11910	8900	80000				
	700	55	110	1,26	18527	8900	81000				
			90	1,55	15158	8900	81000				
			75	1,85	12632	8900	81000				
	500	40	90	1,11	20843	8900	82500				
			75	1,32	17369	8900	82500				
			55	1,80	12737	8900	82500				
15.09	1400	95	132	2,27	12871	8900	80000				
			110	2,73	10726	8900	80000				
			90	3,33	8776	8900	80000				
	900	60	110	1,75	16983	8900	81000				
			90	2,14	13895	8900	81000				
			75	2,56	11579	8900	81000				
	700	50	90	1,66	16674	8900	81000				
			75	1,99	13895	8900	81000				
			55	2,72	10190	8900	81000				
	500	35	75	1,42	19850	8900	82500				
			55	1,94	14557	8900	82500				
			45	2,37	11910	8900	82500				
16.98	1400	82	132	1,83	15285	8900	80000	2A 2AE 501			665 800 675 880
			110	2,20	12737	8900	80000				
			90	2,69	10421	8900	80000				
	900	53	110	1,41	19226	8900	81000				
			90	1,73	15730	8900	81000				
			75	2,07	13109	8900	81000				
	700	41	90	1,34	20335	8900	82500				
			75	1,61	16945	8900	82500				
			55	2,20	12427	8900	82500				
	500	30	75	1,15	23159	8900	82500				
			55	1,56	16983	8900	82500				
			45	1,92	13895	8900	82500				
18.51	1400	76	110	2,22	13408	8900	80000				
			90	2,71	10970	8900	80000				
			75	3,25	9142	8900	80000				
	900	49	90	1,74	17015	8900	82500				
			75	2,09	14149	8900	82500				
			55	2,85	10398	8900	82500				
	700	38	75	1,63	18283	8900	82500				
			55	2,22	13408	8900	82500				
			45	2,71	10970	8900	82500				
	500	27	55	1,58	18870	8900	85000				
			45	1,94	15439	8900	85000				
			37	2,35	12694	8900	85000				





İ Tahvil Oranı Ratio Übersetzung	n ₁	n ₂	P ₁	S _f	M ₂	F _{q1}	F _{qv2}	Tip Type Typ			kg
	Giriş Devri	Çıkış Devri	GÜÇ	Servis Faktörü	Çıkış Momenti	Rad. Yük	Rad. Yük				
	Input Speeds	Output Speeds	Power	Service Factor	Output Torque	Over Loads	Over Loads				
	Antriebswelle Drehzahlen	Abtriebswelle Drehzahlen	Leistung	Betriebsfaktor	Abtriebswelle Drehmomente	Querkräfte	Querkräfte				
	[r.p.m]	[r.p.m]	[kW]		[Nm]	[N]	[N]				
21.50	1400	65	110	1,93	15677	8900	81000	2A 2AE 501			
			90	2,36	12826	8900	81000				
			75	2,83	10689	8900	81000				
	900	42	90	1,51	19850	8900	82500				
			75	1,81	16542	8900	82500				
			55	2,48	12131	8900	82500				
	700	33	75	1,41	21053	8900	82500				
			55	1,93	15439	8900	82500				
			45	2,35	12632	8900	82500				
	500	23	55	1,37	22152	8900	85000				
			45	1,68	18124	8900	85000				
			37	2,04	14902	8900	85000				
25.41	1400	55	90	1,98	15158	8900	81000				
			75	2,38	12632	8900	81000				
			55	3,24	9264	8900	81000				
	900	35	75	1,52	19850	8900	82500				
			55	2,08	14557	8900	82500				
			45	2,54	11910	8900	82500				
	700	28	55	1,62	18196	8900	85000				
			45	1,97	14888	8900	85000				
			37	2,40	12241	8900	85000				
	500	20	45	1,41	20843	8900	85000				
			37	1,71	17137	8900	85000				
			30	2,11	13895	8900	85000				
30.31	1400	45	75	2,25	15200	8900	82500				
			55	3,06	11147	8900	82500				
			45	3,71	9120	8900	82500				
	900	29	55	1,95	17297	8900	85000				
			45	2,41	14152	8900	85000				
			37	2,93	11636	8900	85000				
	700	22	45	1,87	18655	8900	85000				
			37	2,28	15339	8900	85000				
			30	2,81	12437	8900	85000				
	500	16	37	1,62	21091	8900	90000				
			30	2,00	17100	8900	90000				
			22	2,73	12540	8900	90000				
36.59	1400	38	75	2,25	18287	8900	82500				
			55	3,06	13411	8900	82500				
			45	3,71	10972	8900	82500				
	900	25	55	1,95	20384	8900	85000				
			45	2,41	16678	8900	85000				
			37	2,93	13713	8900	85000				
	700	19	45	1,87	21945	8900	85000				
			37	2,28	18044	8900	85000				
			30	2,81	14630	8900	85000				
	500	14	37	1,62	24488	8900	90000				
			30	2,00	19855	8900	90000				
			22	2,73	14560	8900	90000				









İ Tahvil Oranı Ratio Übersetzung	n ₁	n ₂	P ₁	S _f	M ₂	F _{q1}	F _{qv2}	Tip Type Typ			kg
	Giriş Devri	Çıkış Devri	GÜÇ	Servis Faktörü	Çıkış Momenti	Rad. Yük	Rad. Yük				
	Input Speeds	Output Speeds	Power	Service Factor	Output Torque	Over Loads	Over Loads				
	Antriebswelle Drehzahlen	Abtriebswelle Drehzahlen	Leistung	Betriebsfaktor	Abtriebswelle Drehmomente	Querkräfte	Querkräfte				
	[r.p.m]	[r.p.m]	[kW]		[Nm]	[N]	[N]				
25.24	1400	56	75	1,67	12215	7600	64500				
			55	2,28	8957	7600	64500				
			45	2,80	7329	7600	64500				
	900	36	55	1,46	13934	7600	68000				
			45	1,78	11400	7600	68000				
			37	2,17	9374	7600	68000				
	700	28	45	1,39	14658	7600	70000				
			37	1,68	12052	7600	70000				
			30	2,08	9772	7600	70000				
	500	20	37	1,21	16872	7600	70000				
			30	1,49	13680	7600	70000				
			22	2,03	10032	7600	70000				
29.77	1400	47	55	2,02	10673	7600	68000	3A 3AE 430	666	546	
			45	2,47	8732	7600	68000				
			37	3,00	7180	7600	68000				
	900	30	45	1,58	13680	7600	68000				
			37	1,93	11248	7600	68000				
			30	2,38	9120	7600	68000				
	700	24	37	1,50	14060	7600	70000				
			30	1,85	11400	7600	70000				
			22	2,52	8360	7600	70000				
	500	17	30	1,32	16095	7600	70000				
			22	1,80	11803	7600	70000				
			18,5	2,15	9925	7600	70000				
33.41	1400	42	55	2,00	11943	7600	68000				
			45	2,44	9772	7600	68000				
			37	2,97	8035	7600	68000				
	900	27	45	1,57	15200	7600	70000				
			37	1,90	12498	7600	70000				
			30	2,35	10134	7600	70000				
	700	21	37	1,48	16069	7600	70000				
			30	1,82	13029	7600	70000				
			22	2,48	9555	7600	70000				
	500	15	30	1,30	18241	7600	70000				
			22	1,77	13376	7600	70000				
			18,5	2,11	11248	7600	70000				
40.07	1400	35	55	1,54	14332	7600	68000				
			45	1,88	11726	7600	68000				
			37	2,29	9641	7600	68000				
	900	23	45	1,21	17844	7600	70000				
			37	1,47	14672	7600	70000				
			30	1,82	11896	7600	70000				
	700	18	37	1,15	18747	7600	70000				
			30	1,41	15200	7600	70000				
			22	1,93	11147	7600	70000				
	500	13	30	1,01	21047	7600	72500				
			22	1,38	15434	7600	72500				
			18,5	1,64	12979	7600	72500				





İ Tahvil Oranı Ratio Übersetzung	n ₁	n ₂	P ₁	S _f	M ₂	F _{q1}	F _{q2}	Tip Type Typ			kg
	Giriş Devri	Çıkış Devri	GÜÇ	Servis Faktörü	Çıkış Momenti	Rad. Yük	Rad. Yük				
	Input Speeds	Output Speeds	Power	Service Factor	Output Torque	Over Loads	Over Loads				
	Antriebswelle Drehzahlen	Abtriebswelle Drehzahlen	Leistung	Betriebsfaktor	Abtriebswelle Drehmomente	Querkräfte	Querkräfte				
	[r.p.m]	[r.p.m]	[kW]		[Nm]	[N]	[N]				
49.89	1400	28	45	1,46	14658	7600	70000	3A 3AE 430	666	546	621
			37	1,77	12052	7600	70000				
			30	2,19	9772	7600	70000				
	900	18	37	1,14	18747	7600	70000				
			30	1,40	15200	7600	70000				
			22	1,91	11147	7600	70000				
	700	14	30	1,09	19543	7600	72500				
			22	1,48	14332	7600	72500				
			18,5	1,77	12052	7600	72500				
	500	10	22	1,06	20065	7600	72500				
			18,5	1,26	16872	7600	72500				
			15	1,55	13680	7600	72500				
56.62	1400	25	37	1,60	13498	7600	70000				
			30	1,97	10944	7600	70000				
			22	2,69	8026	7600	70000				
	900	16	30	1,27	17100	7600	70000				
			22	1,73	12540	7600	70000				
			18,5	2,06	10545	7600	70000				
	700	12	22	1,35	16720	7600	72500				
			18,5	1,60	14060	7600	72500				
			15	1,98	11400	7600	72500				
	500	9	18,5	1,14	18747	7600	74000				
			15	1,40	15200	7600	74000				
			11	1,92	11147	7600	74000				
71.98	1400	20	30	1,55	13680	7600	70000				
			22	2,11	10032	7600	70000				
			18,5	2,51	8436	7600	70000				
	900	13	22	1,36	15434	7600	72500				
			18,5	1,62	12979	7600	72500				
			15	1,99	10523	7600	72500				
	700	10	18,5	1,25	16872	7600	72500				
			15	1,55	13680	7600	72500				
			11	2,11	10032	7600	72500				
	500	7	15	1,10	19543	7600	74000				
			11	1,50	14332	7600	74000				
			7,5	2,20	9772	7600	74000				
83.18	1400	17	22	1,99	11803	7600	70000				
			18,5	2,37	9925	7600	70000				
			15	2,92	8047	7600	70000				
	900	11	18,5	1,52	15339	7600	72500				
			15	1,87	12437	7600	72500				
			11	2,55	9120	7600	72500				
	700	8,5	15	1,45	16095	7600	74000				
			11	1,99	11803	7600	74000				
			7,5	2,92	8047	7600	74000				
	500	6	11	1,42	16720	7600	74000				
			7,5	2,08	11400	7600	74000				
			5,5	2,84	8360	7600	74000				













İ Tahvil Oranı Ratio Übersetzung	n ₁	n ₂	P ₁	S _f	M ₂	F _{q1}	F _{qv2}	Tip Type Typ			kg
	Giriş Devri	Çıkış Devri	GÜÇ	Servis Faktörü	Çıkış Momenti	Rad. Yük	Rad. Yük				
	Input Speeds	Output Speeds	Power	Service Factor	Output Torque	Over Loads	Over Loads				
	Antriebswelle Drehzahlen	Abtriebswelle Drehzahlen	Leistung	Betriebsfaktor	Abtriebswelle Drehmomente	Querkräfte	Querkräfte				
	[r.p.m]	[r.p.m]	[kW]		[Nm]	[N]	[N]				
99.05	1400	14	18,5	1,41	12052	7600	72500	3A 3AE 430			
			15	1,74	9772	7600	72500				
			11	2,37	7166	7600	72500				
	900	9	15	1,12	15200	7600	74000				
			11	1,53	11147	7600	74000				
			7,5	2,24	7600	7600	74000				
	700	7	11	1,18	14332	7600	74000				
			7,5	1,72	9772	7600	74000				
			5,5	2,35	7166	7600	74000				
	500	5	7,5	1,23	13680	7600	74000				
			5,5	1,68	10032	7600	74000				
			4	2,31	7296	7600	74000				
121.40	1400	11,5	11	1,58	8724	7600	72500				
			7,5	2,32	5948	7600	72500				
			5,5	3,16	4362	7600	72500				
	900	7,5	7,5	1,49	9120	7600	74000				
			5,5	2,03	6688	7600	74000				
			4	2,79	4864	7600	74000				
	700	6	5,5	1,59	8360	7600	74000				
			4	2,19	6080	7600	74000				
			3	2,92	4560	7600	74000				
	500	4	4	1,55	9120	7600	74000				
			3	2,06	6840	7600	74000				
			2,2	2,81	5016	7600	74000				
144.85	1400	9,5	7,5	1,96	7200	7600	74000	3A 3AE 501			
			5,5	2,68	5280	7600	74000				
			4	3,69	3840	7600	74000				
	900	6,2	5,5	1,72	8091	7600	74000				
			4	2,37	5884	7600	74000				
			3	3,16	4413	7600	74000				
	700	5	4	1,84	7296	7600	74000				
			3	2,45	5472	7600	74000				
			2,2	3,34	4013	7600	74000				
	500	3,5	3	1,78	7817	7600	74000				
			2,2	2,43	5733	7600	74000				
			1,5	3,57	3909	7600	74000				
38.34	1400	37	55	1,96	13557	7500	82500				
			45	2,39	11092	7500	82500				
			37	2,91	9120	7500	82500				
	900	23	45	1,54	17844	7500	85000				
			37	1,87	14672	7500	85000				
			30	2,31	11896	7500	85000				
	700	18	37	1,45	18747	7500	90000				
			30	1,79	15200	7500	90000				
			22	2,44	11147	7500	90000				
	500	13	30	1,27	21047	7500	95000				
			22	1,74	15434	7500	95000				
			18,5	2,07	12979	7500	95000				





İ Tahvil Oranı Ratio Übersetzung	n ₁	n ₂	P ₁	S _f	M ₂	F _{q1}	F _{qv2}	Tip Type Typ			kg
	Giriş Devri	Çıkış Devri	GÜÇ	Servis Faktörü	Çıkış Momenti	Rad. Yük	Rad. Yük				
	Input Speeds	Output Speeds	Power	Service Factor	Output Torque	Over Loads	Over Loads				
	Antriebswelle Drehzahlen	Abtriebswelle Drehzahlen	Leistung	Betriebsfaktor	Abtriebswelle Drehmomente	Querkräfte	Querkräfte				
	[r.p.m]	[r.p.m]	[kW]		[Nm]	[N]	[N]				
49.86	1400	28	45	1,87	14658	7500	85000				
			37	2,27	12052	7500	85000				
			30	2,81	9772	7500	85000				
	900	18	37	1,45	18747	7500	90000				
			30	1,80	15200	7500	90000				
			22	2,45	11147	7500	90000				
	700	14	30	1,40	19543	7500	95000				
			22	1,90	14332	7500	95000				
			18,5	2,26	12052	7500	95000				
	500	10	22	1,36	20065	7500	95000				
			18,5	1,62	16872	7500	95000				
			15	1,99	13680	7500	95000				
76.13	1400	18	37	1,59	18747	7500	90000				
			30	1,95	15200	7500	90000				
			22	2,67	11147	7500	90000				
	900	12	30	1,26	22801	7500	95000				
			22	1,71	16720	7500	95000				
			18,5	2,04	14060	7500	95000				
	700	9	22	1,34	22294	7500	100000				
			18,5	1,59	18747	7500	100000				
			15	1,96	15200	7500	100000				
	500	6,5	18,5	1,12	25958	7500	100000				
			15	1,38	21047	7500	100000				
			11	1,89	15434	7500	100000				
101.38	1400	14	22	1,63	14332	7500	95000	3A 3AE 501			
			18,5	1,94	12052	7500	95000				
			15	2,39	9772	7500	95000				
	900	9	18,5	1,23	18747	7500	100000				
			15	1,52	15200	7500	100000				
			11	2,08	11147	7500	100000				
	700	7	15	1,19	19543	7500	100000				
			11	1,63	14332	7500	100000				
			7,5	2,39	9772	7500	100000				
	500	5	11	1,15	20065	7500	100000				
			7,5	1,70	13680	7500	100000				
			5,5	2,31	10032	7500	100000				
148.69	1400	9,5	18,5	1,60	17760	7500	100000				
			15	1,97	14400	7500	100000				
			11	2,68	10560	7500	100000				
	900	6	15	1,97	22801	7500	100000				
			11	2,69	16720	7500	100000				
			7,5	3,95	11400	7500	100000				
	700	5	11	1,35	20065	7500	100000				
			7,5	1,97	13680	7500	100000				
			5,5	2,69	10032	7500	100000				
	500	3,5	7,5	1,42	19543	7500	100000				
			5,5	1,95	14332	7500	100000				
			4	2,67	10423	7500	100000				





İ Tahvil Oranı Ratio Übersetzung	n ₁	n ₂	P ₁	S _f	M ₂	F _{q1}	F _{q2}	Tip Type Typ			kg
	Giriş Devri	Çıkış Devri	GÜÇ	Servis Faktörü	Çıkış Momenti	Rad. Yük	Rad. Yük				
	Input Speeds	Output Speeds	Power	Service Factor	Output Torque	Over Loads	Over Loads				
	Antriebswelle Drehzahlen	Abtriebswelle Drehzahlen	Leistung	Betriebsfaktor	Abtriebswelle Drehmomente	Querkräfte	Querkräfte				
	[r.p.m]	[r.p.m]	[kW]		[Nm]	[N]	[N]				
213.93	1400	6,5	15	1,39	21047	7500	100000	3A 3AE 501			
			11	1,90	15434	7500	100000				
			7,5	2,78	10523	7500	100000				
	900	4	11	1,22	25081	7500	100000				
			7,5	1,80	17100	7500	100000				
			5,5	2,45	12540	7500	100000				
	700	3,3	7,5	1,41	20728	7500	100000				
			5,5	1,92	15200	7500	100000				
			4	2,65	11055	7500	100000				
	500	2,3	5,5	1,34	21809	7500	100000				
			4	1,84	15861	7500	100000				
			3	2,46	11896	7500	100000				
310.01	1400	4,5	11	1,21	22294	7500	100000	3A 3AE 501			
			7,5	1,77	15200	7500	100000				
			5,5	2,42	11147	7500	100000				
	900	3	7,5	1,14	22801	7500	100000				
			5,5	1,55	16720	7500	100000				
			4	2,14	12160	7500	100000				
	700	2,2	5,5	1,18	22801	7500	100000				
			4	1,63	16582	7500	100000				
			3	2,17	12437	7500	100000				
	500	1,6	4	1,18	22801	7500	100000				
			3	1,58	17100	7500	100000				
			2,2	2,15	12540	7500	100000				
15.01	1400	93	185	2,60	18142	7750	135000	3A 3AE 750			
			160	3,01	15691	7750	135000				
			132	3,65	12945	7750	135000				
	900	60	160	1,93	24321	7750	135000				
			132	2,34	20065	7750	135000				
			110	2,81	16720	7750	135000				
	700	47	132	1,82	25614	7750	137500				
			110	2,18	21345	7750	137500				
			90	2,67	17464	7750	137500				
	500	33	110	1,56	30401	7750	139000				
			90	1,90	24873	7750	139000				
			75	2,28	20728	7750	139000				
16.49	1400	85	160	2,87	17168	7750	135000	3A 3AE 750			
			132	3,48	14163	7750	135000				
			110	4,17	11803	7750	135000				
	900	55	132	2,23	21889	7750	137500				
			110	2,68	18241	7750	137500				
			90	3,28	14924	7750	137500				
	700	42	110	2,08	23886	7750	139000				
			90	2,54	19543	7750	139000				
			75	3,05	16286	7750	139000				
	500	30	90	1,82	27361	7750	139000				
			75	2,18	22801	7750	139000				
			55	2,98	16720	7750	139000				





İ Tahvil Oranı Ratio Übersetzung	n ₁	n ₂	P ₁	S _f	M ₂	F _{q1}	F _{qv2}	Tip Type Typ			kg
	Giriş Devri	Çıkış Devri	GÜÇ	Servis Faktörü	Çıkış Momenti	Rad. Yük	Rad. Yük				
	Input Speeds	Output Speeds	Power	Service Factor	Output Torque	Over Loads	Over Loads				
	Antriebswelle Drehzahlen	Abtriebswelle Drehzahlen	Leistung	Betriebsfaktor	Abtriebswelle Drehmomente	Querkräfte	Querkräfte				
	[r.p.m]	[r.p.m]	[kW]		[Nm]	[N]	[N]				
18.17	1400	77	132	3,13	15635	7750	135000				
			110	3,76	13029	7750	135000				
			90	4,59	10660	7750	135000				
	900	50	110	2,41	20065	7750	137500				
			90	2,95	16416	7750	137500				
			75	3,54	13680	7750	137500				
	700	39	90	2,29	21047	7750	139000				
			75	2,75	17539	7750	139000				
			55	3,75	12862	7750	139000				
	500	28	75	1,96	24429	7750	140500				
			55	2,67	17915	7750	140500				
			45	3,27	14658	7750	140500				
20.58	1400	68	132	2,02	17704	7750	135000				
			110	2,43	14753	7750	135000				
			90	2,97	12071	7750	135000				
	900	44	110	1,56	22801	7750	139000				
			90	1,91	18655	7750	139000				
			75	2,29	15546	7750	139000				
	700	34	90	1,48	24142	7750	139000				
			75	1,77	20118	7750	139000				
			55	2,42	14753	7750	139000				
	500	24	75	1,27	28501	7750	140500				
			55	1,73	20901	7750	140500				
			45	2,11	17100	7750	140500				
25.29	1400	55	110	1,96	18241	7750	137500	3A	750	668	1380
			90	2,39	14924	7750	137500				
			75	2,87	12437	7750	137500				
	900	36	90	1,54	22801	7750	139000				
			75	1,85	19001	7750	139000				
			55	2,52	13934	7750	139000				
	700	28	75	1,43	24429	7750	140500				
			55	1,96	17915	7750	140500				
			45	2,40	14658	7750	140500				
	500	20	55	1,40	25081	7750	140500				
			45	1,71	20521	7750	140500				
			37	2,08	16872	7750	140500				
34.96	1400	43	75	2,01	15907	7750	139000				
			55	2,75	11665	7750	139000				
			45	3,35	9544	7750	139000				
	900	27	55	1,76	18578	7750	140500				
			45	2,15	15200	7750	140500				
			37	2,62	12498	7750	140500				
	700	21	45	1,67	19543	7750	140500				
			37	2,03	16069	7750	140500				
			30	2,50	13029	7750	140500				
	500	15	37	1,45	22497	7750	142700				
			30	1,80	18241	7750	142700				
			22	2,45	13376	7750	142700				





İ Tahvil Oranı Ratio Übersetzung	n ₁	n ₂	P ₁	S _f	M ₂	F _{q1}	F _{qv2}	Tip Type Typ			kg
	Giriş Devri	Çıkış Devri	GÜÇ	Servis Faktörü	Çıkış Momenti	Rad. Yük	Rad. Yük				
	Input Speeds	Output Speeds	Power	Service Factor	Output Torque	Over Loads	Over Loads				
	Antriebswelle Drehzahlen	Abtriebswelle Drehzahlen	Leistung	Betriebsfaktor	Abtriebswelle Drehmomente	Querkräfte	Querkräfte				
	[r.p.m]	[r.p.m]	[kW]		[Nm]	[N]	[N]				
44.31	1400	32	55	2,09	15675	7750	139000				
			45	2,56	12825	7750	139000				
			37	3,11	10545	7750	139000				
	900	20	45	1,64	20521	7750	140500				
			37	1,99	16872	7750	140500				
			30	2,46	13680	7750	140500				
	700	16	37	1,55	21091	7750	142700				
			30	1,91	17100	7750	142700				
			22	2,61	12540	7750	142700				
	500	11	30	1,37	24873	7750	142700				
			22	1,86	18241	7750	142700				
			18,5	2,22	15339	7750	142700				
63.88	1400	22	37	2,13	15339	7750	140500				
			30	2,63	12437	7750	140500				
			22	3,58	9120	7750	140500				
	900	14	30	1,69	19543	7750	142700				
			22	2,31	14332	7750	142700				
			18,5	2,75	12052	7750	142700				
	700	11	22	1,78	18241	7750	142700				
			18,5	2,12	15339	7750	142700				
			15	2,61	12437	7750	142700				
	500	8	18,5	1,52	21091	7750	145500				
			15	1,87	17100	7750	145500				
			11	2,55	12540	7750	145500				
81.75	1400	17	22	2,58	11803	7750	142700	3A 3AE 750			
			18,5	3,06	9925	7750	142700				
			15	3,78	8047	7750	142700				
	900	11	18,5	1,97	15339	7750	142700				
			15	2,43	12437	7750	142700				
			11	3,32	9120	7750	142700				
	700	8,5	15	1,90	16095	7750	145500				
			11	2,59	11803	7750	145500				
			7,5	3,81	8047	7750	145500				
	500	6	11	1,84	16720	7750	145500				
			7,5	2,70	11400	7750	145500				
			5,5	3,68	8360	7750	145500				
118.50	1400	12	18,5	2,17	14060	7750	142700				
			15	2,67	11400	7750	142700				
			11	3,64	8360	7750	142700				
	900	7,5	15	1,72	18241	7750	145500				
			11	2,35	13376	7750	145500				
			7,5	3,44	9120	7750	145500				
	700	6	11	1,82	16720	7750	145500				
			7,5	2,67	11400	7750	145500				
			5,5	3,65	8360	7750	145500				
	500	4	7,5	1,90	17100	7750	145500				
			5,5	2,60	12540	7750	145500				
			4	3,57	9120	7750	145500				



İ Tahvil Oranı Ratio Übersetzung	n ₁	n ₂	P ₁	S _f	M ₂	F _{q1}	F _{qv2}	Tip Type Typ			kg
	Giriş Devri	Çıkış Devri	GÜÇ	Servis Faktörü	Çıkış Momenti	Rad. Yük	Rad. Yük				
	Input Speeds	Output Speeds	Power	Service Factor	Output Torque	Over Loads	Over Loads				
	Antriebswelle Drehzahlen	Abtriebswelle Drehzahlen	Leistung	Betriebsfaktor	Abtriebswelle Drehmomente	Querkräfte	Querkräfte				
	[r.p.m]	[r.p.m]	[kW]		[Nm]	[N]	[N]				
140.30	1400	10	15	2,69	13680	7750	142700				
			11	3,67	10032	7750	142700				
			7,5	5,38	6840	7750	142700				
	900	6,5	11	2,35	15434	7750	145500				
			7,5	3,44	10523	7750	145500				
			5,5	4,69	7717	7750	145500				
	700	5	7,5	2,69	13680	7750	145500				
			5,5	3,66	10032	7750	145500				
			4	5,04	7296	7750	145500				
	500	3,5	5,5	2,64	14332	7750	145500				
			4	3,63	10423	7750	145500				
			3	4,84	7817	7750	145500				
154.20	1400	9	15	2,20	14978	7150	147000	4A 750	669	1410	
			11	3,01	10984	7150	147000				
			7,5	4,41	7489	7150	147000				
	900	6	11	1,92	16475	7150	147000				
			7,5	2,81	11233	7150	147000				
			5,5	3,83	8238	7150	147000				
	700	4,5	7,5	2,17	14978	7150	147000				
			5,5	2,96	10984	7150	147000				
			4	4,08	7988	7150	147000				
	500	3,2	5,5	2,11	15446	7150	147000				
			4	2,90	11233	7150	147000				
			3	3,86	8425	7150	147000				
187.10	1400	7,5	15	1,82	17973	7150	147000				
			11	2,48	13180	7150	147000				
			7,5	3,64	8987	7150	147000				
	900	5	11	1,60	19770	7150	147000				
			7,5	2,35	13480	7150	147000				
			5,5	3,20	9885	7150	147000				
	700	3,8	7,5	1,82	17737	7150	147000				
			5,5	2,48	13007	7150	147000				
			4	3,41	9460	7150	147000				
	500	2,7	5,5	1,76	18306	7150	147000				
			4	2,42	13313	7150	147000				
			3	3,23	9985	7150	147000				
222.23	1400	6	11	2,10	16475	7150	147000				
			7,5	3,08	11233	7150	147000				
			5,5	4,20	8238	7150	147000				
	900	4	7,5	1,95	16850	7150	147000				
			5,5	2,65	12357	7150	147000				
			4	3,65	8987	7150	147000				
	700	3	5,5	2,06	16475	7150	147000				
			4	2,84	11982	7150	147000				
			3	3,78	8987	7150	147000				
	500	2	4	2,01	17973	7150	147000				
			3	2,68	13480	7150	147000				
			2,2	3,66	9885	7150	147000				



İ Tahvil Oranı Ratio Übersetzung	n ₁	n ₂	P ₁	S _f	M ₂	F _{q1}	F _{qv2}	Tip Type Typ	  kg
	Giriş Devri	Çıkış Devri	GÜÇ	Servis Faktörü	Çıkış Momenti	Rad. Yük	Rad. Yük		
	Input Speeds	Output Speeds	Power	Service Factor	Output Torque	Over Loads	Over Loads		
	Antriebswelle Drehzahlen	Abtriebswelle Drehzahlen	Leistung	Betriebsfaktor	Abtriebswelle Drehmomente	Querkräfte	Querkräfte		
	[r.p.m]	[r.p.m]	[kW]		[Nm]	[N]	[N]		
282.32	1400	5	7,5	2,25	13480	7150	147000	4A 750 669 1410	
			5,5	3,60	9885	7150	147000		
			4	4,21	7189	7150	147000		
	900	3,2	5,5	2,00	15446	7150	147000		
			4	2,75	11233	7150	147000		
			3	3,67	8425	7150	147000		
	700	2,5	4	2,15	14378	7150	147000		
			3	2,86	10784	7150	147000		
			2,2	3,91	7908	7150	147000		
	500	1,7	3	1,95	15859	7150	147000		
			2,2	2,66	11630	7150	147000		
			1,5	3,90	7929	7150	147000		
327.87	1400	4,2	7,5	1,98	14340	7150	147000		
			5,5	2,70	10516	7150	147000		
			4	3,71	7648	7150	147000		
	900	2,7	5,5	1,74	18306	7150	147000		
			4	2,38	13313	7150	147000		
			3	3,18	9985	7150	147000		
	700	2	4	1,85	17973	7150	147000		
			3	2,47	13480	7150	147000		
			2,2	3,37	9885	7150	147000		
	500	1,5	3	1,77	17973	7150	147000		
			2,2	2,41	13180	7150	147000		
			1,5	3,53	8987	7150	147000		
412.40	1400	3,5	5,5	2,15	14122	7150	147000		
			4	2,95	10270	7150	147000		
			3	3,94	7703	7150	147000		
	900	2,2	4	1,91	16339	7150	147000		
			3	2,55	12254	7150	147000		
			2,2	3,48	8987	7150	147000		
	700	1,7	3	1,97	15859	7150	147000		
			2,2	2,68	11630	7150	147000		
			1,5	3,94	7929	7150	147000		
	500	1,2	2,2	1,89	16475	7150	147000		
			1,5	2,78	11233	7150	147000		
			1,1	3,79	8238	7150	147000		
487.32	1400	3	5,5	1,84	16475	7150	147000		
			4	2,53	11982	7150	147000		
			3	3,37	8987	7150	147000		
	900	1,8	4	1,57	19970	7150	147000		
			3	2,09	14978	7150	147000		
			2,2	2,85	10984	7150	147000		
	700	1,4	3	1,63	19257	7150	147000		
			2,2	2,22	14122	7150	147000		
			1,5	3,25	9628	7150	147000		
	500	1	2,2	1,58	19770	7150	147000		
			1,5	2,32	13480	7150	147000		
			1,1	3,17	9885	7150	147000		



A 200

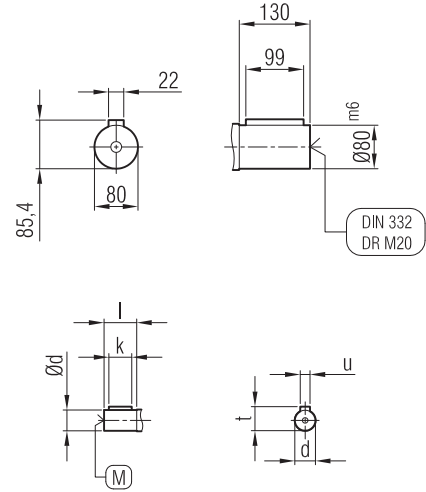
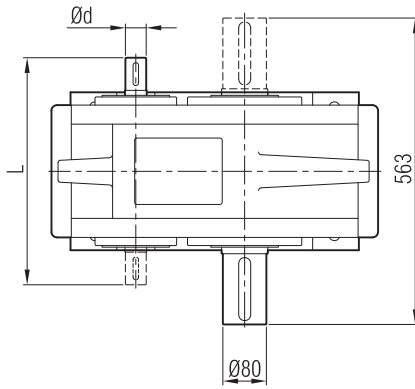
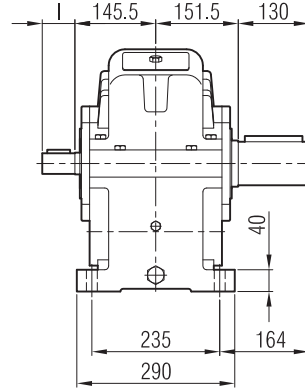
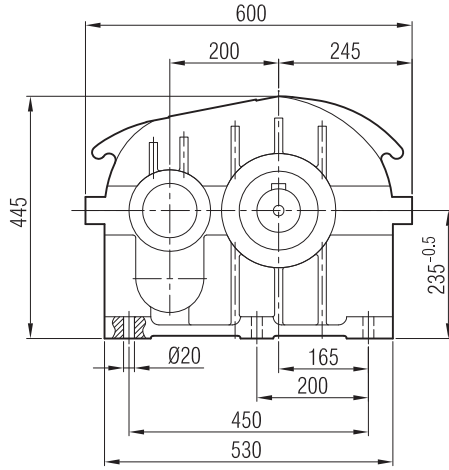

M	d	u	t	k	l	L	Tahvil
M20	55	16	59,3	75	90	471	$i \leq 2,84$
M16	48	14	51,8	65	80	451	$3 < i \leq 6,91$

Bağlantı Pozisyonları

Mounting Positions

Bauformen

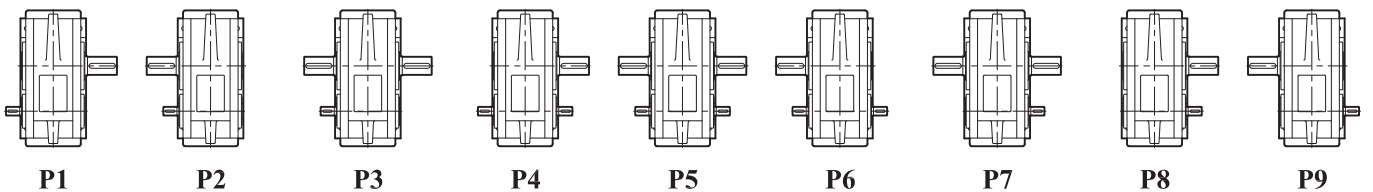



2A 200

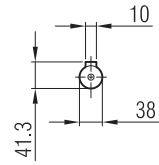
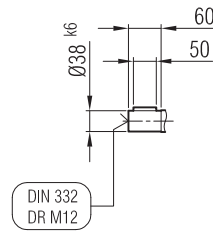
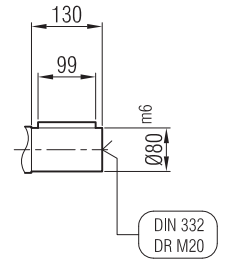
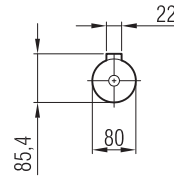
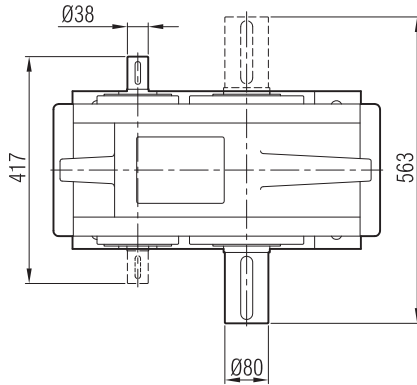
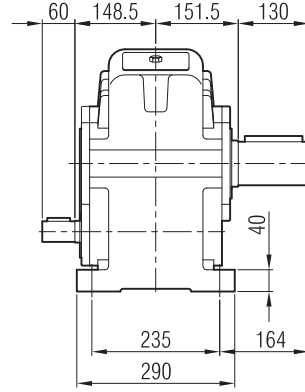
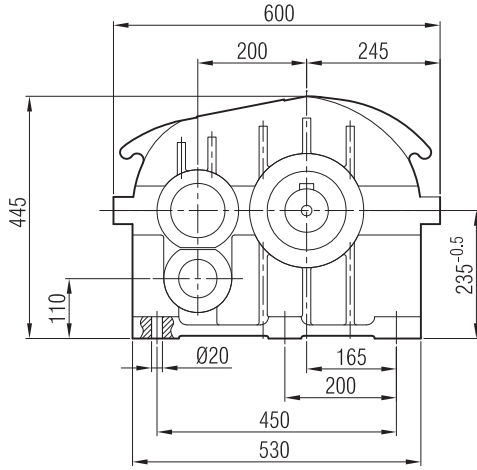

Bağlantı Pozisyonları

Mounting Positions

Bauformen

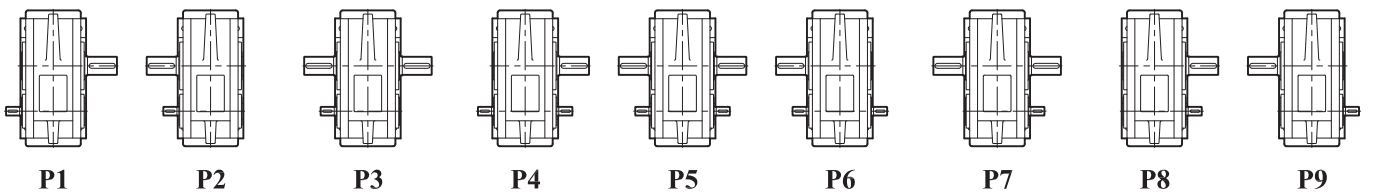



2A 180

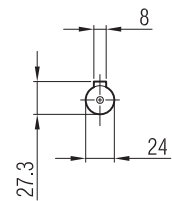
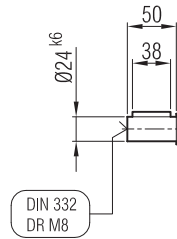
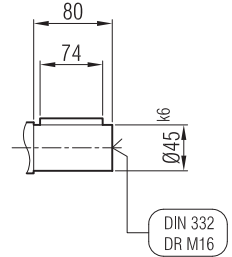
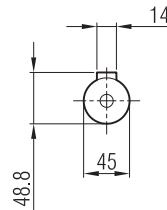
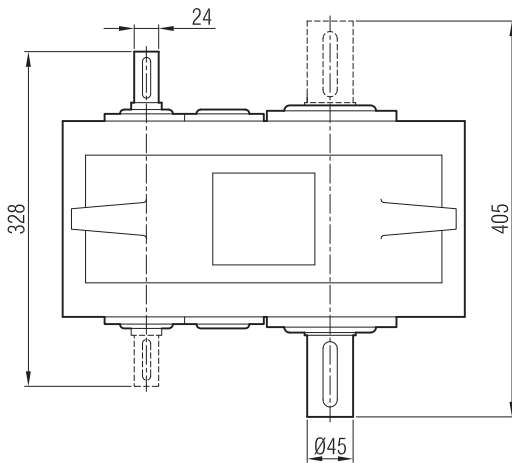
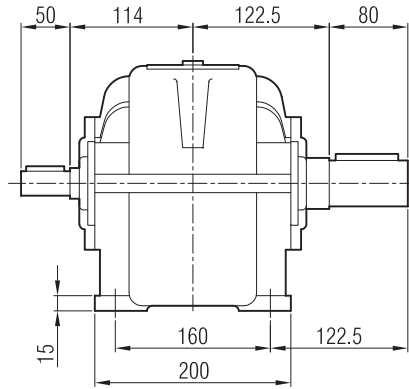
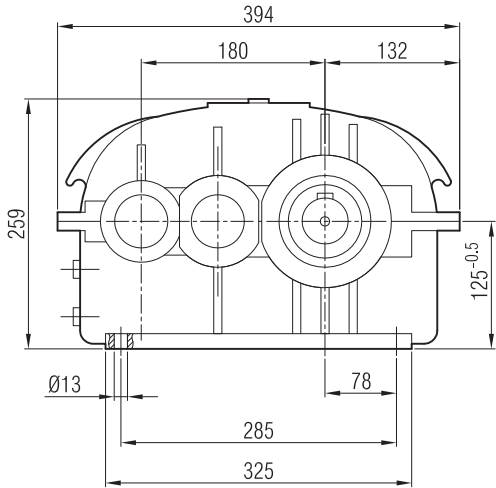

Bağlantı Pozisyonları

Mounting Positions

Bauformen

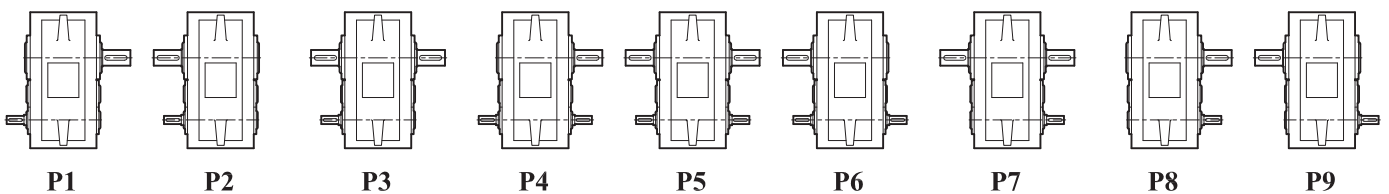



2A 225

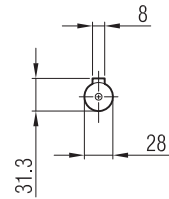
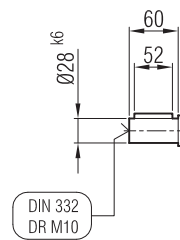
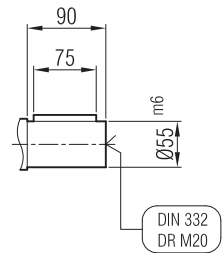
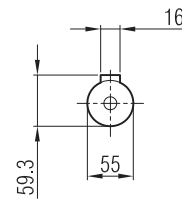
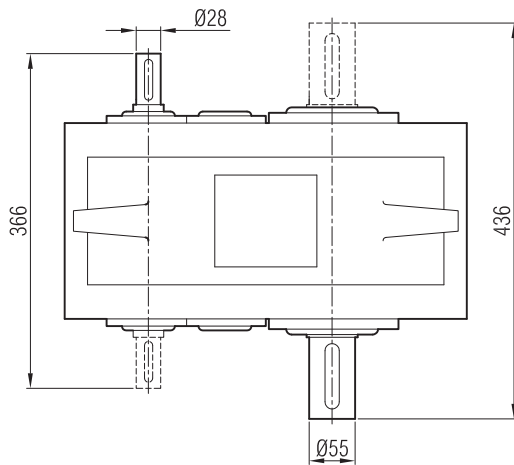
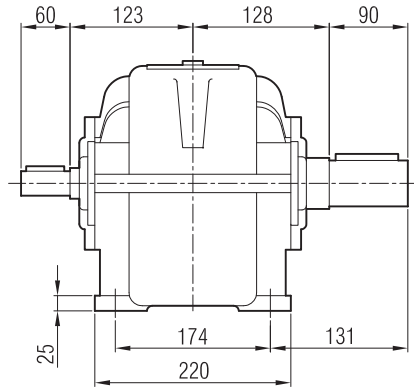
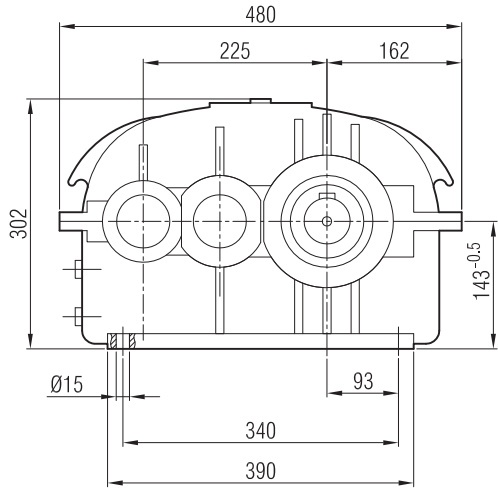

Bağlantı Pozisyonları

Mounting Positions

Bauformen

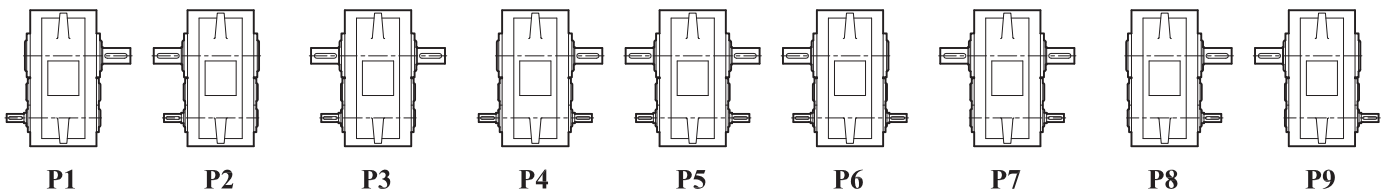



2A 275

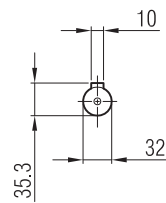
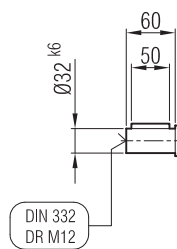
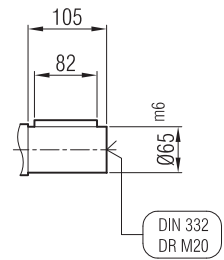
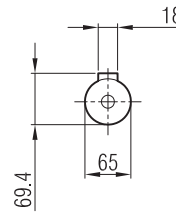
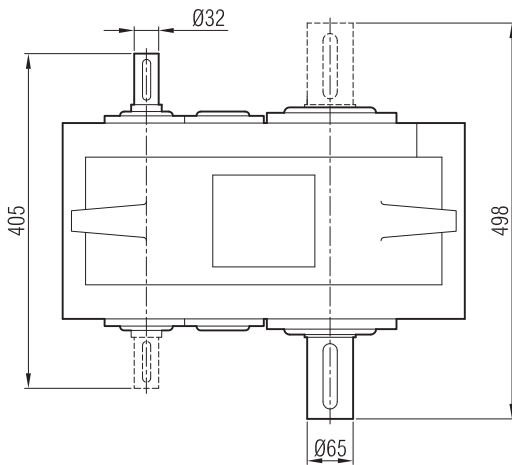
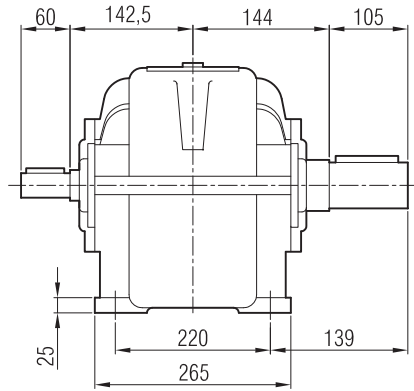
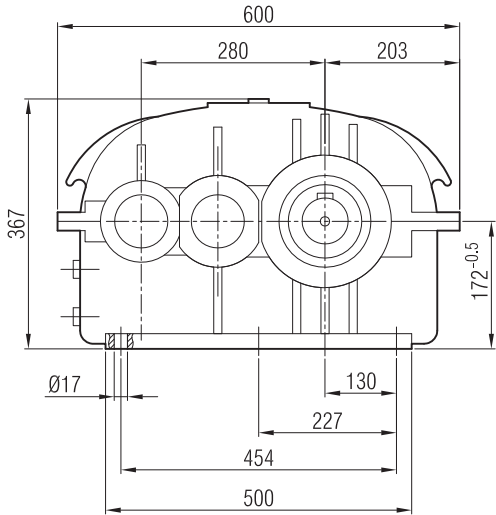

Bağlantı Pozisyonları

Mounting Positions

Bauformen

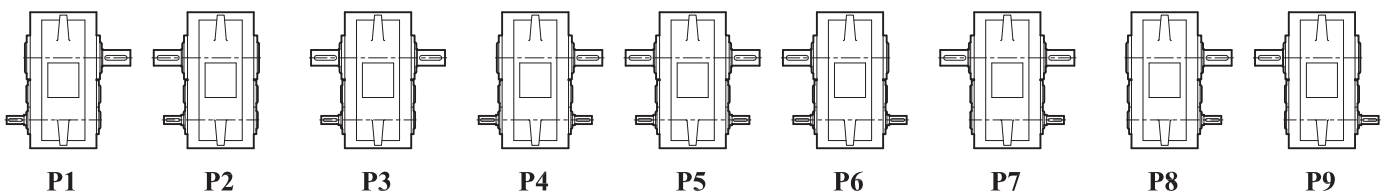



2A 350

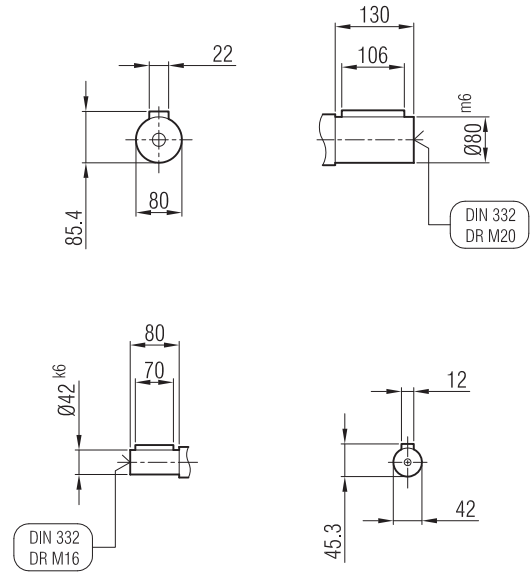
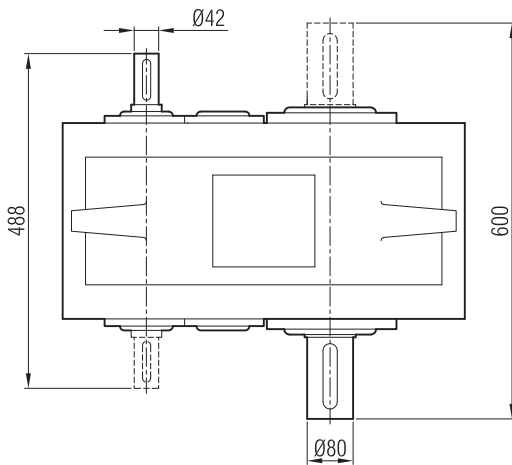
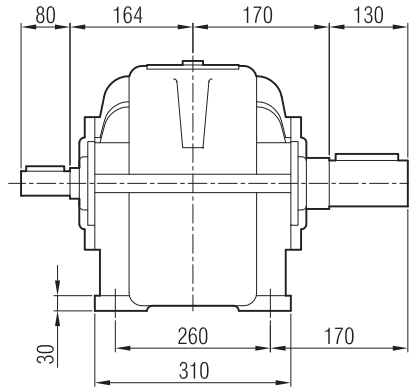
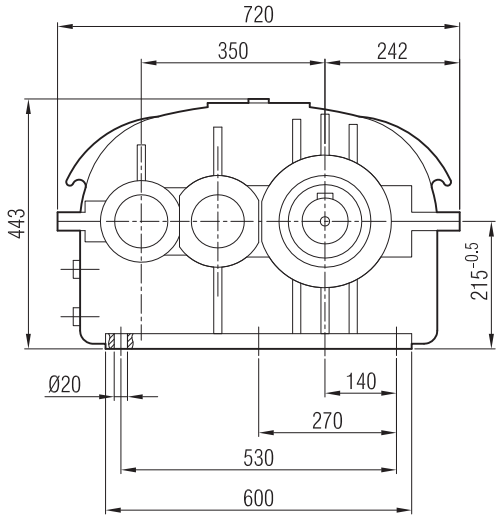

Bağlantı Pozisyonları

Mounting Positions

Bauformen

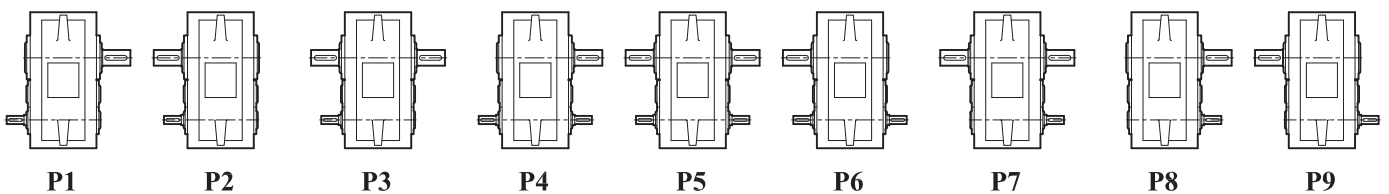



2A 430

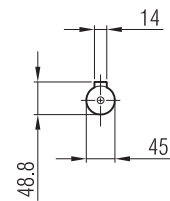
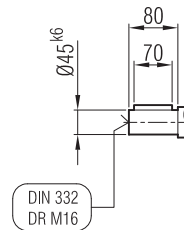
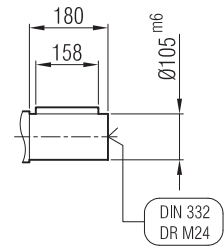
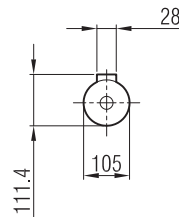
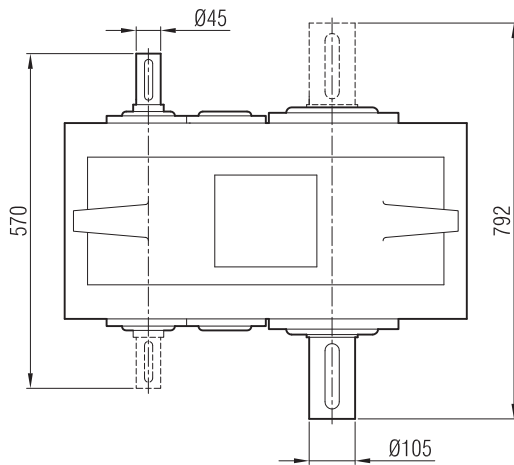
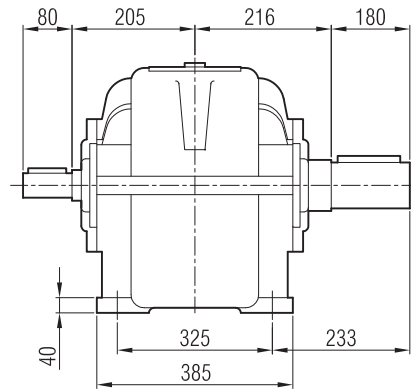
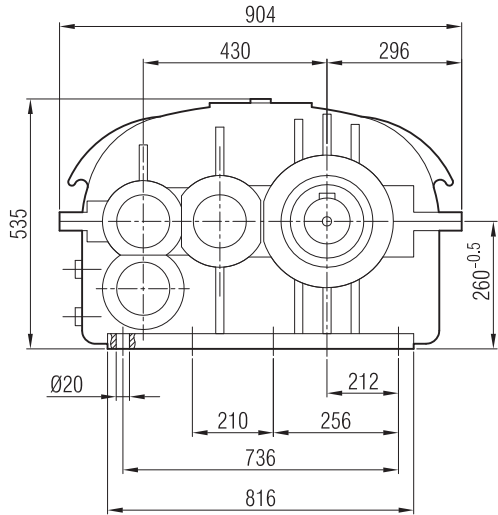

Bağlantı Pozisyonları

Mounting Positions

Bauformen

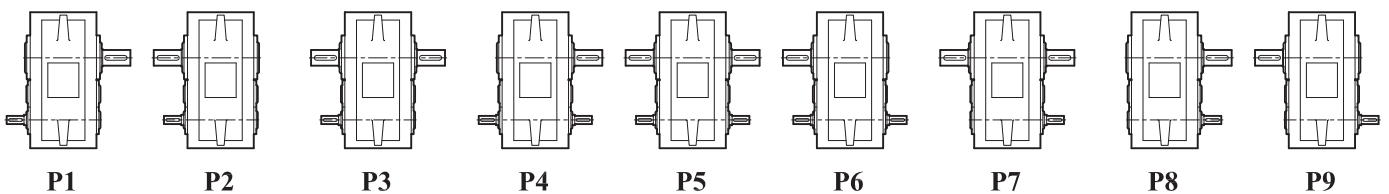



3A 430

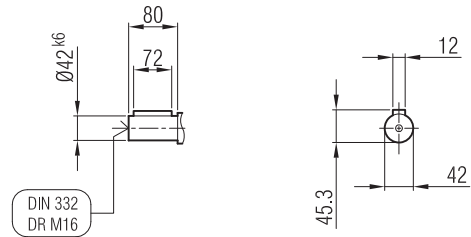
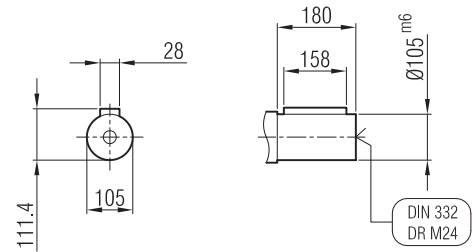
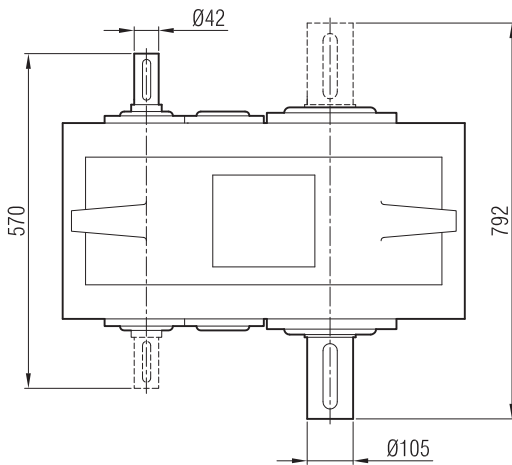
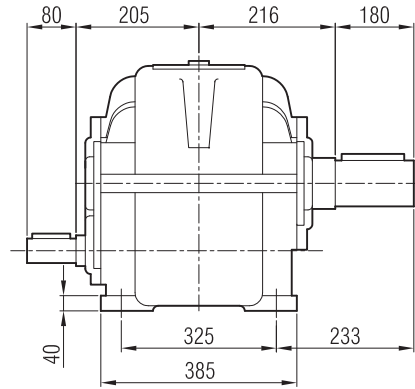
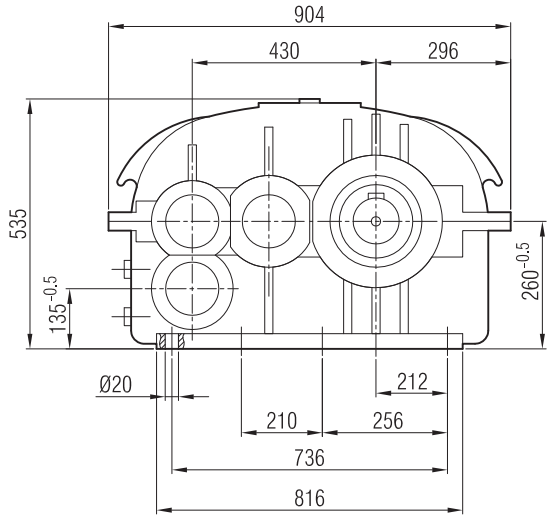

Bağlantı Pozisyonları

Mounting Positions

Bauformen

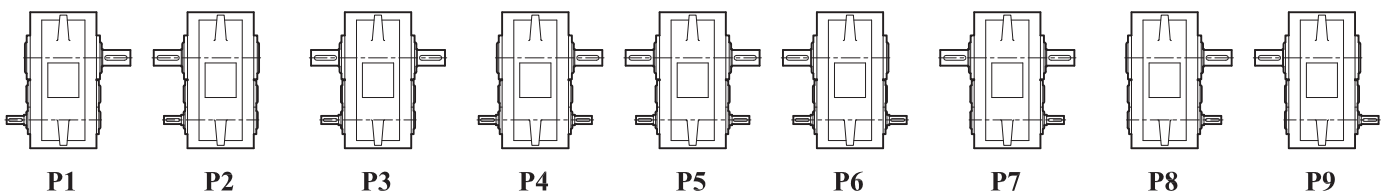

2A 501

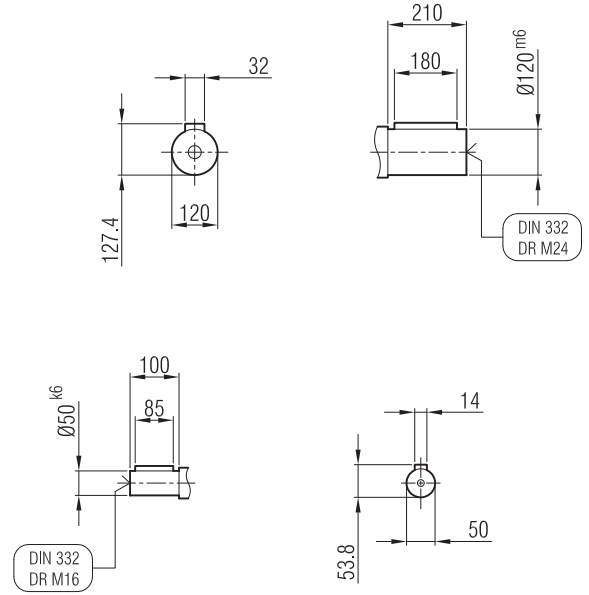
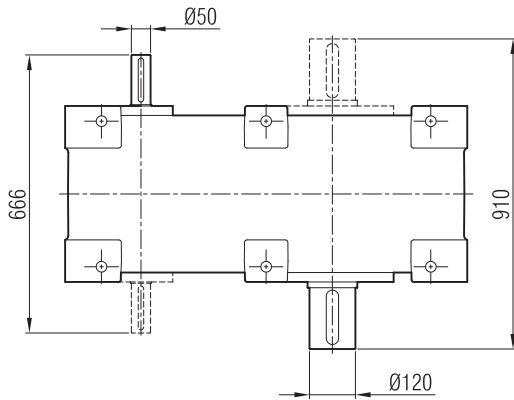
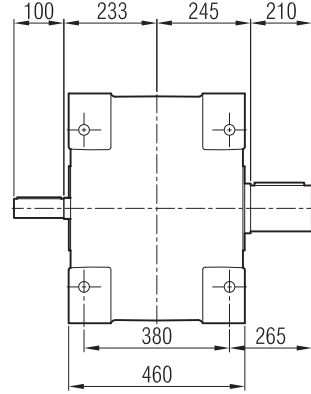
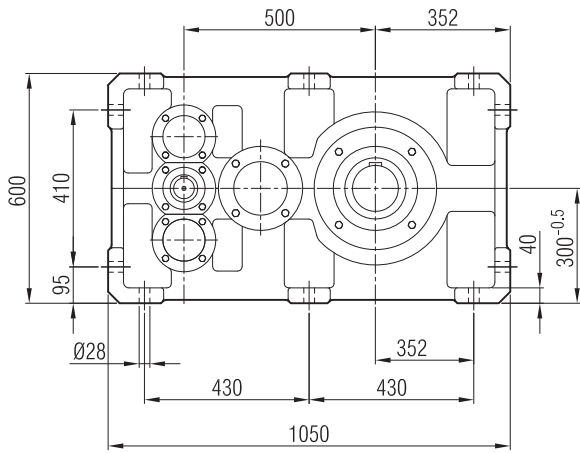

Bağlantı Pozisyonları

Mounting Positions

Bauformen

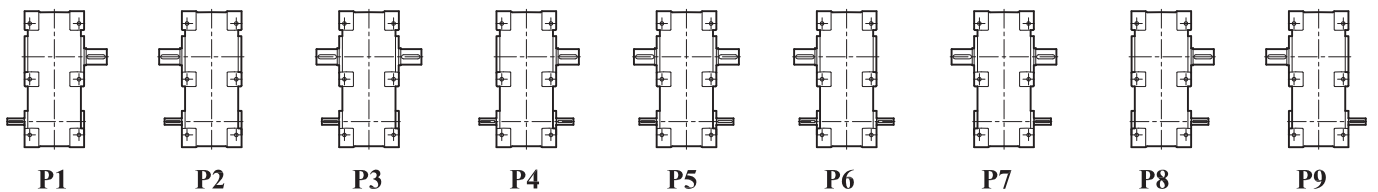

3A 501

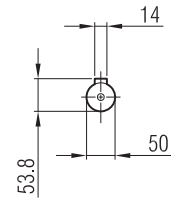
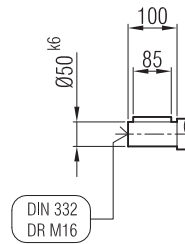
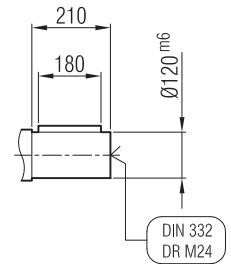
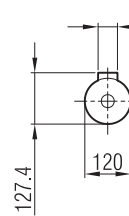
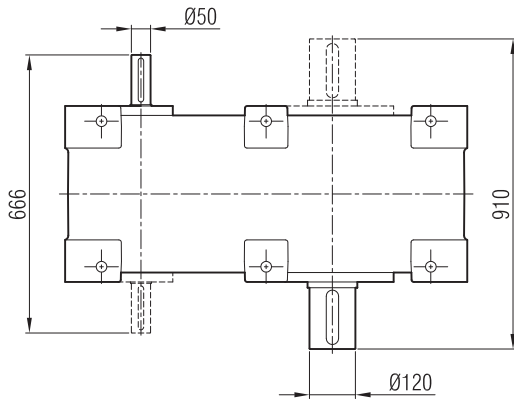
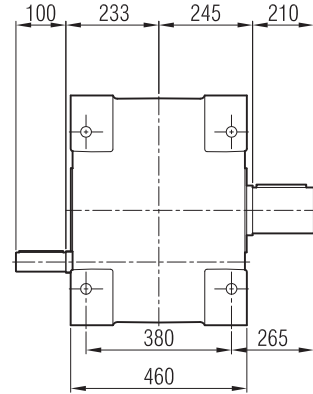
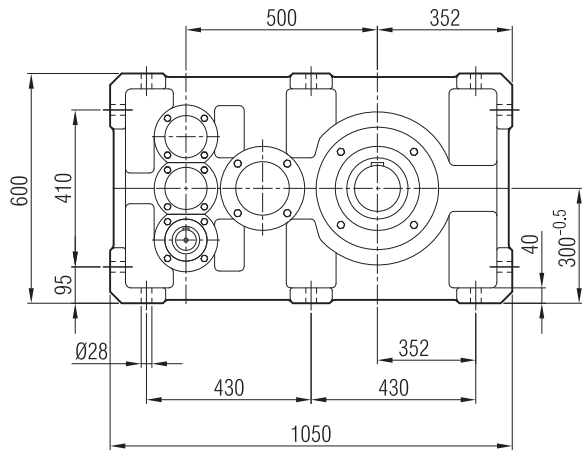

Bağlantı Pozisyonları

Mounting Positions

Bauformen

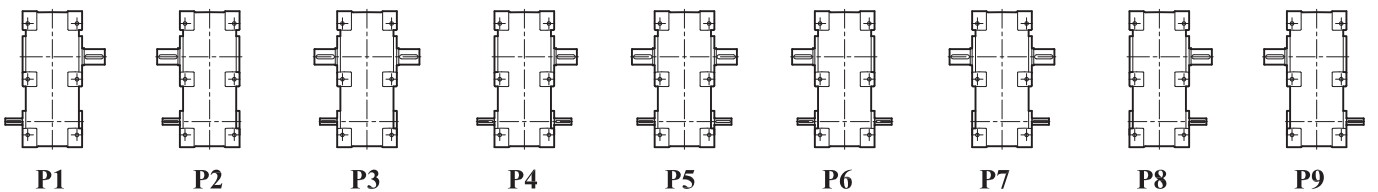



3A 750

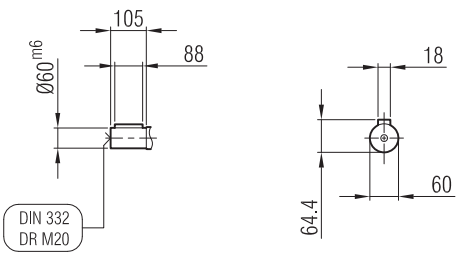
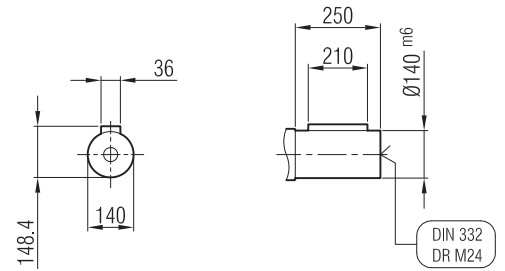
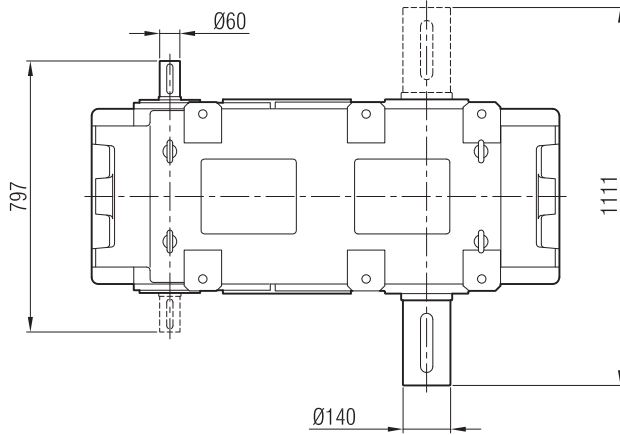
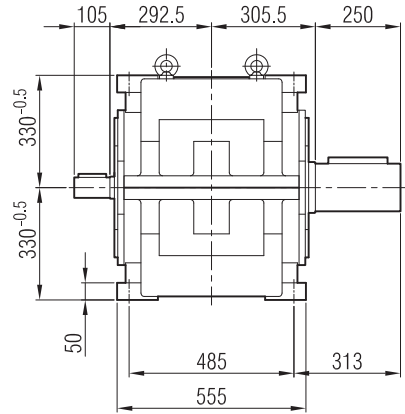
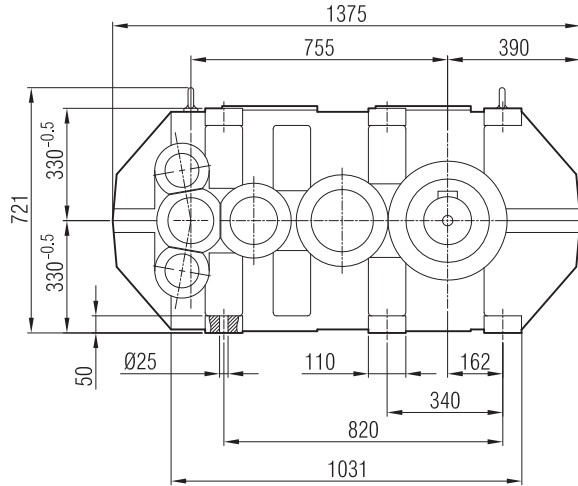

Bağlantı Pozisyonları

Mounting Positions

Bauformen

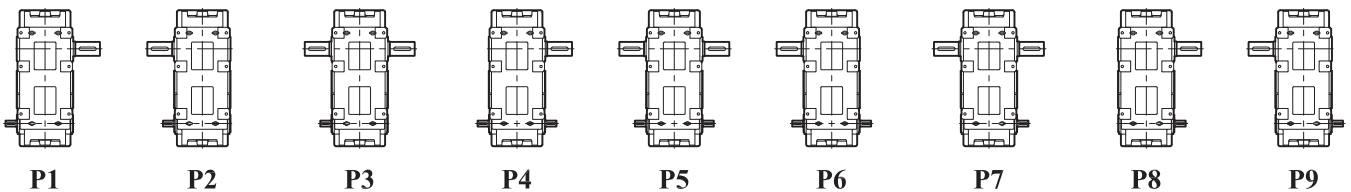



4A 750

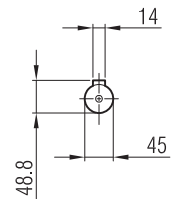
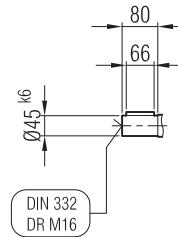
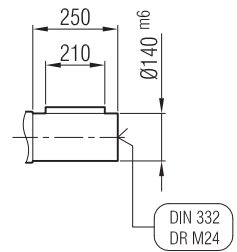
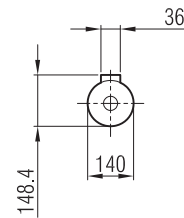
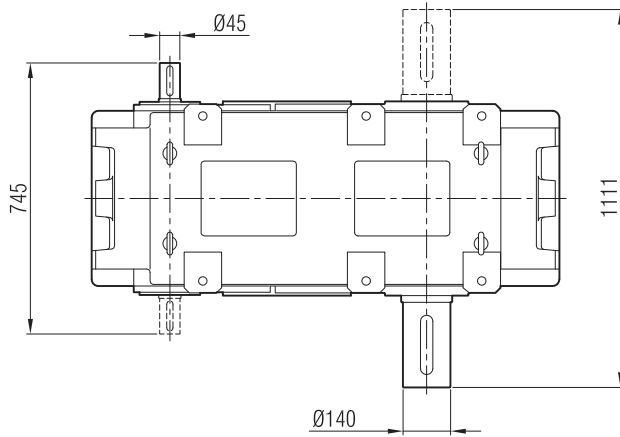
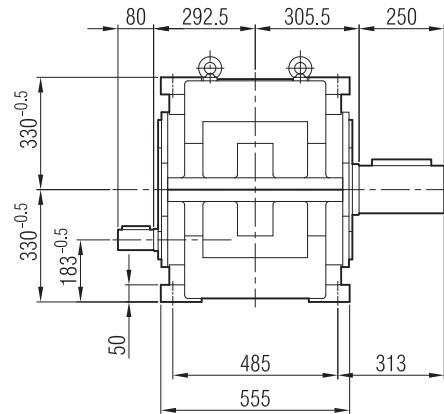
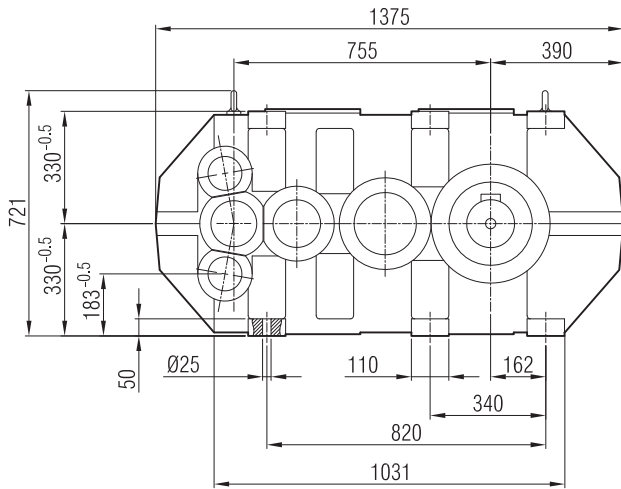

Bağlantı Pozisyonları

Mounting Positions

Bauformen

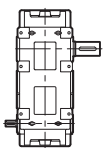

P1

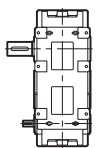

P2

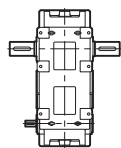

P3

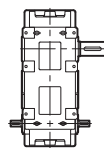

P4

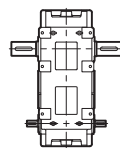

P5

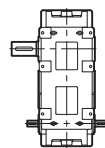

P6

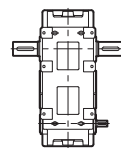

P7

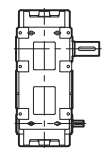

P8

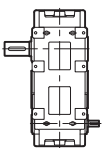

P9

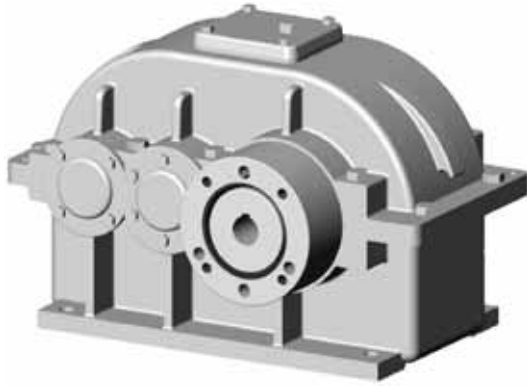

2AE ...

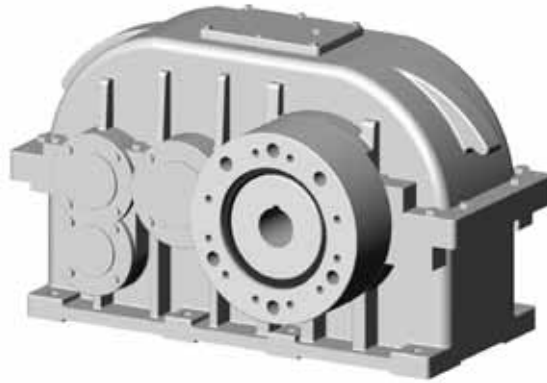

3AE ...

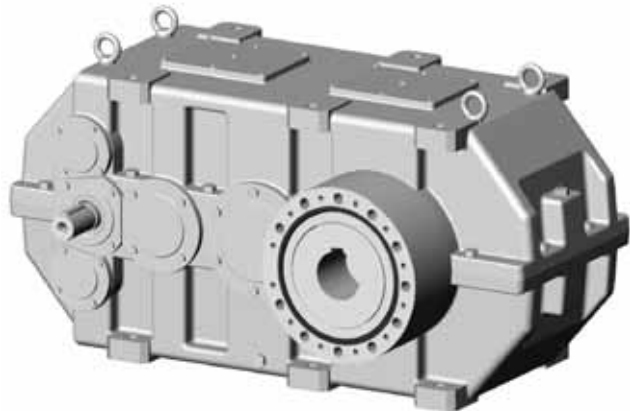

3AE 750



2AE 225

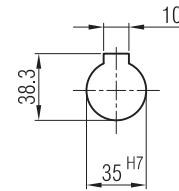
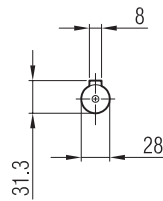
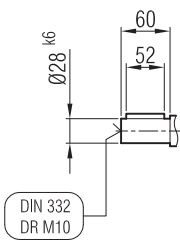
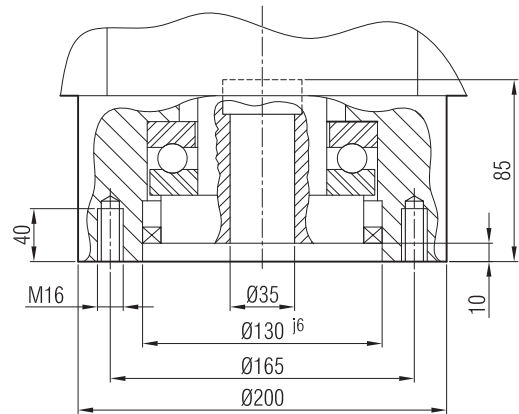
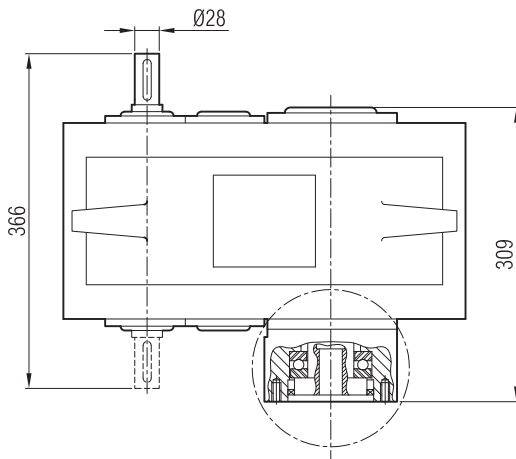
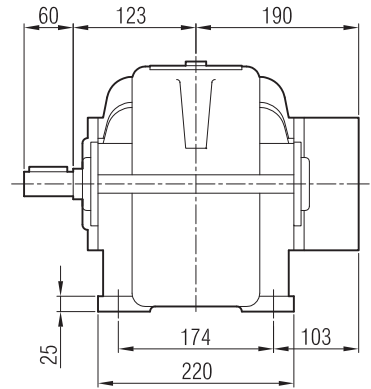
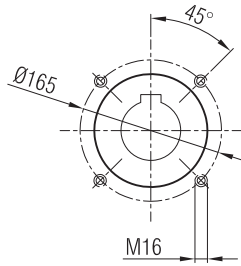
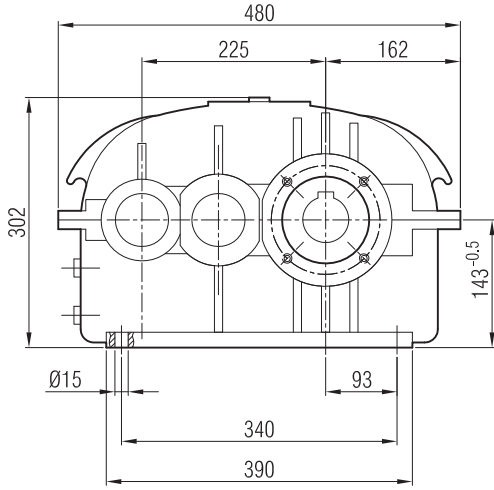

Bağlantı Pozisyonları

Mounting Positions

Bauformen

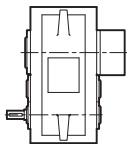

P1

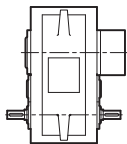

P4

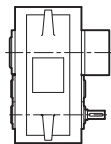

P8





2AE 275

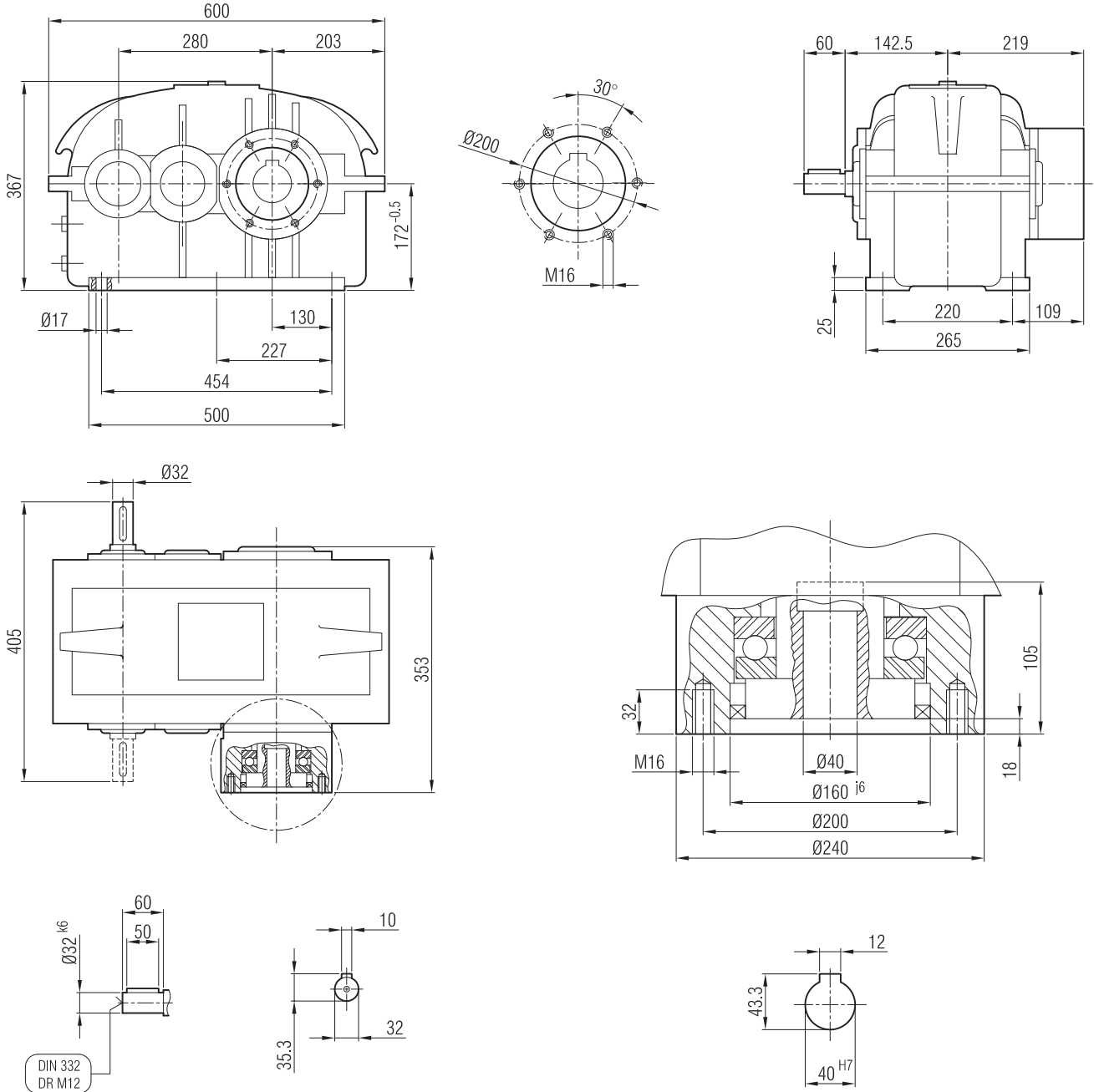

Bağlantı Pozisyonları

Mounting Positions

Bauformen

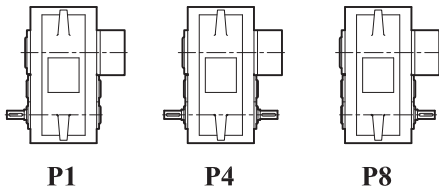



2AE 350

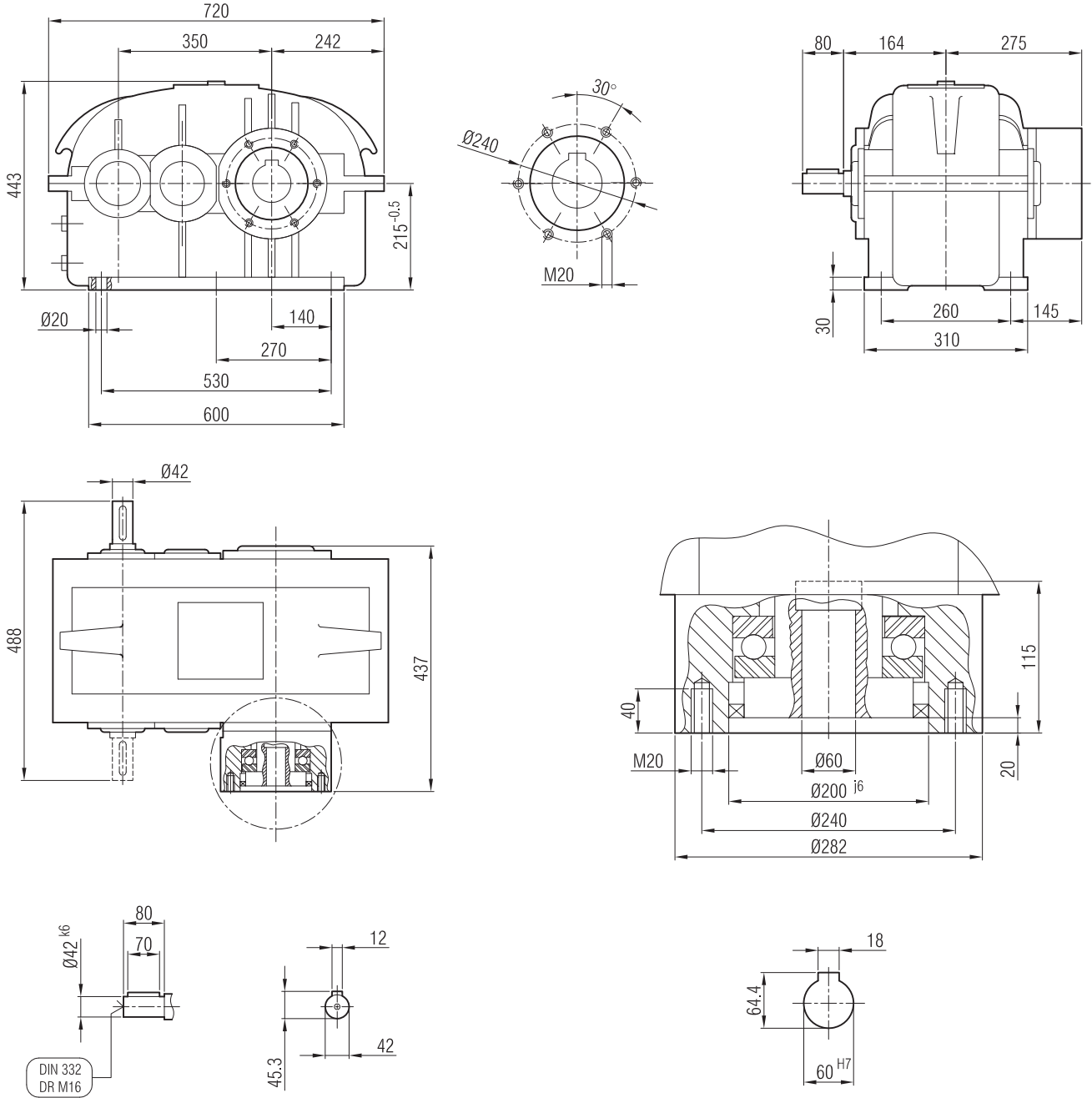

Bağlantı Pozisyonları

Mounting Positions

Bauformen

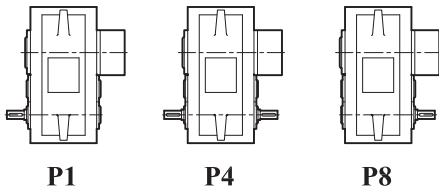

P1

P4

P8





2AE 430

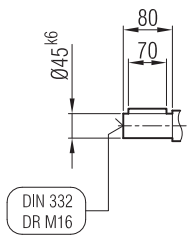
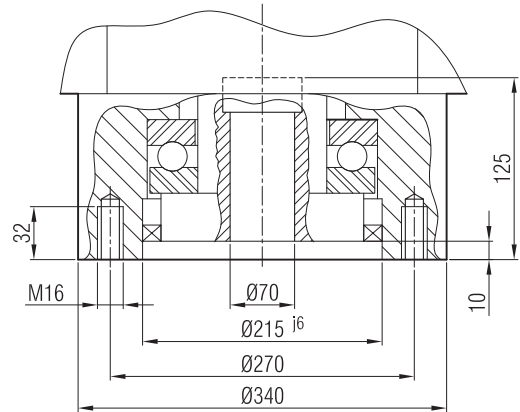
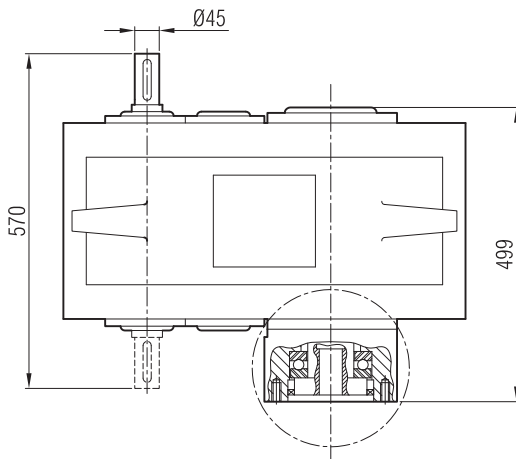
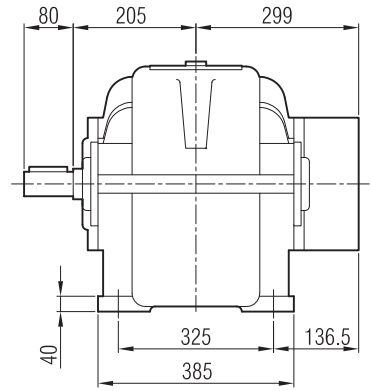
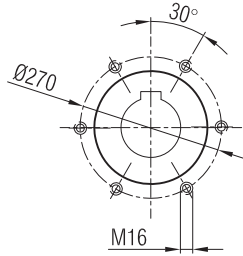
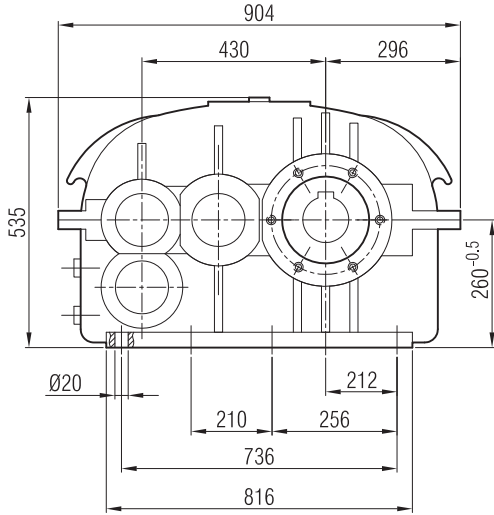

DIN 332
DR M16

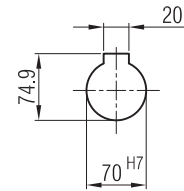
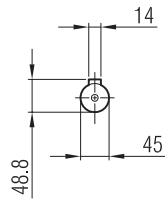

Bağlantı Pozisyonları

Mounting Positions

Bauformen

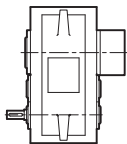

P1

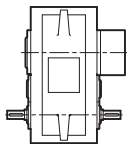

P4

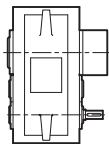

P8





3AE 430

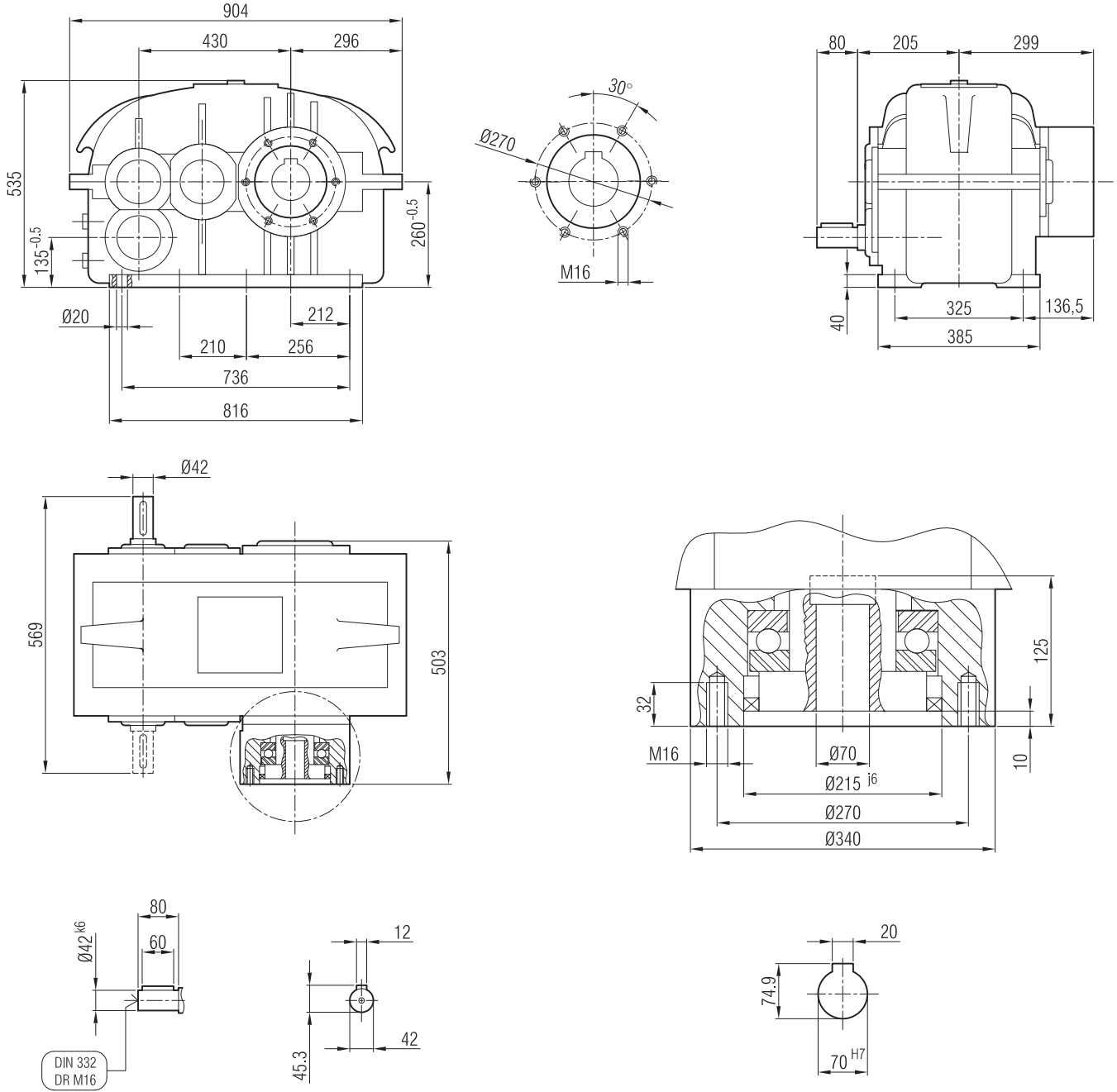

Bağlantı Pozisyonları

Mounting Positions

Bauformen

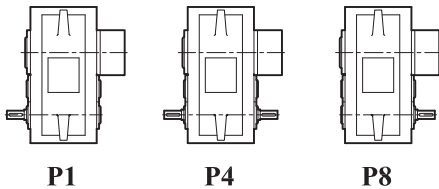

2A 501

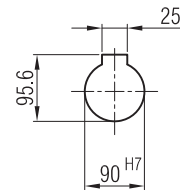
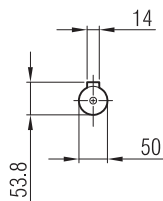
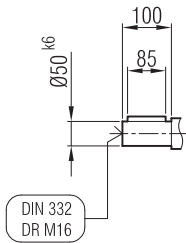
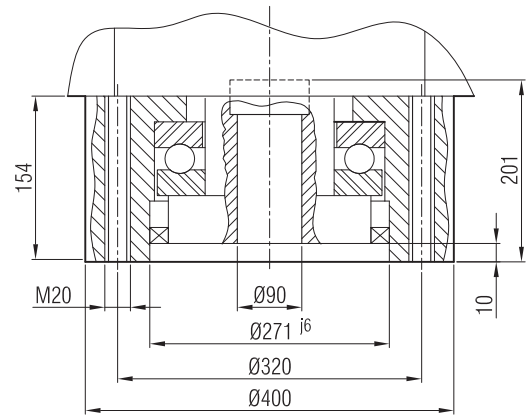
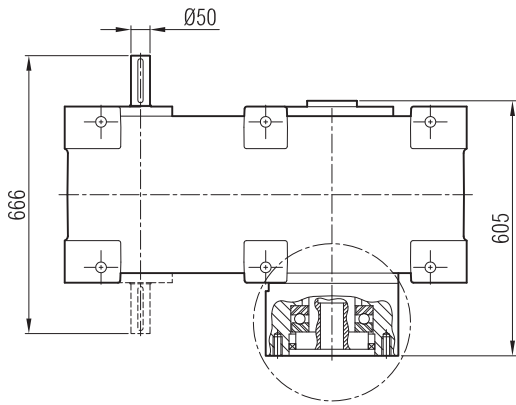
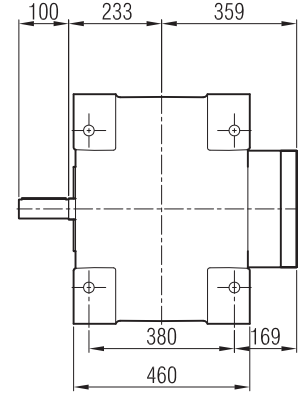
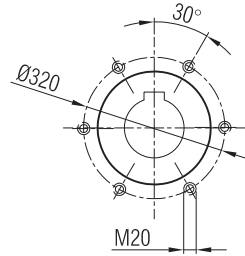
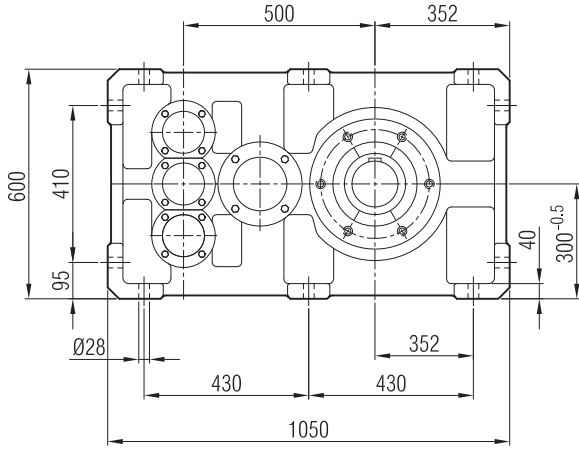

Bağlantı Pozisyonları

Mounting Positions

Bauformen

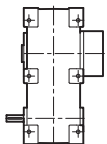

P1

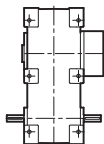

P4

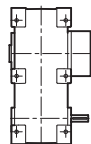

P8



3A 501

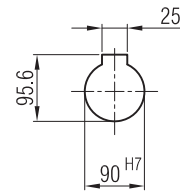
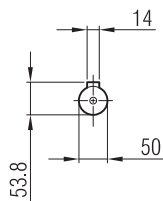
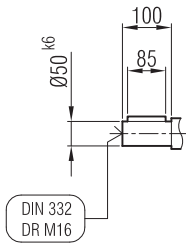
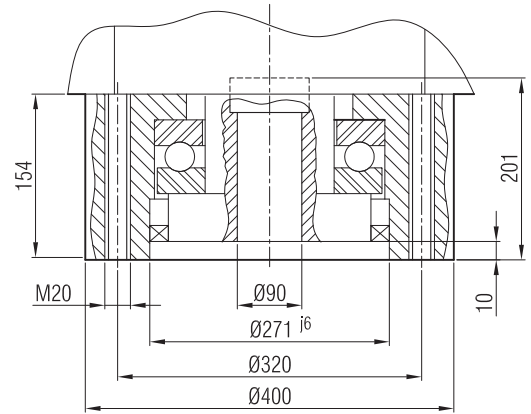
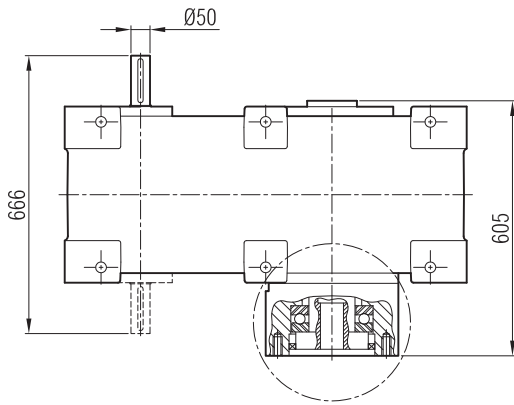
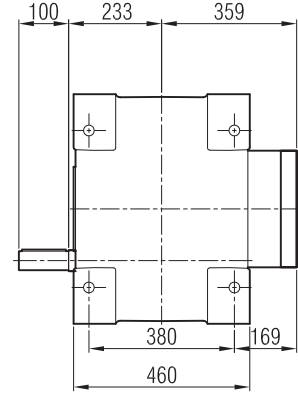
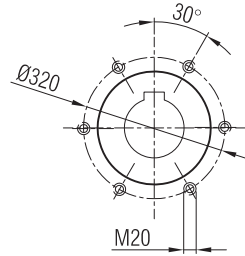
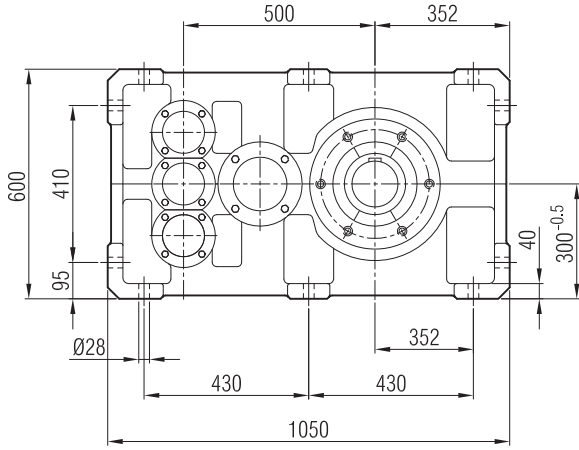

Bağlantı Pozisyonları

Mounting Positions

Bauformen

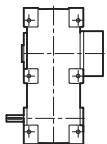

P1

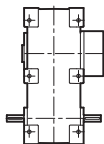

P4

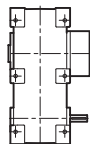

P8





3AE 750

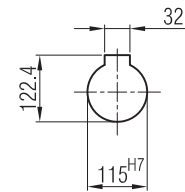
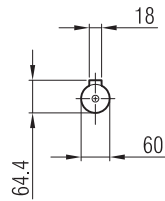
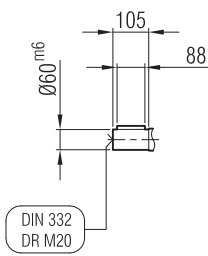
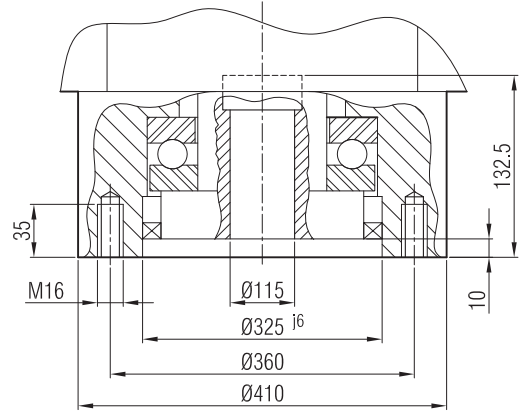
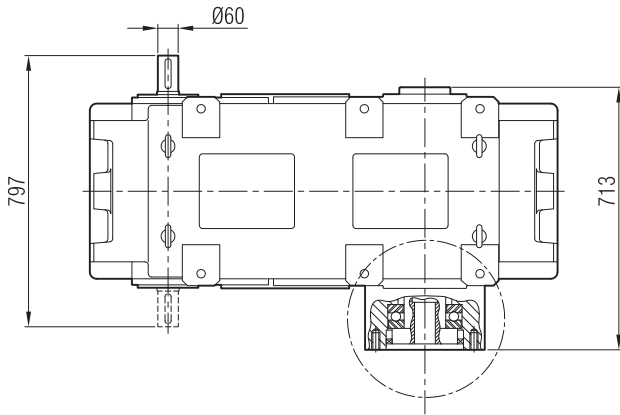
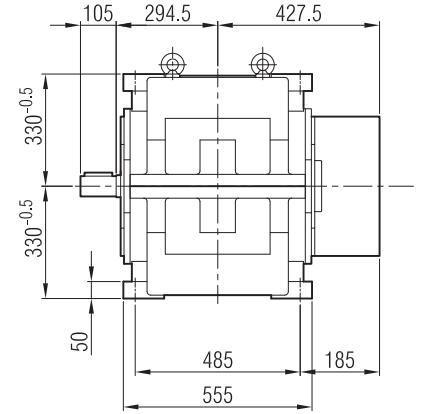
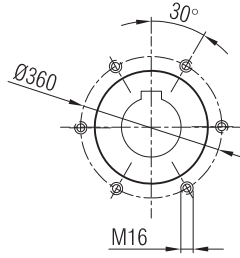
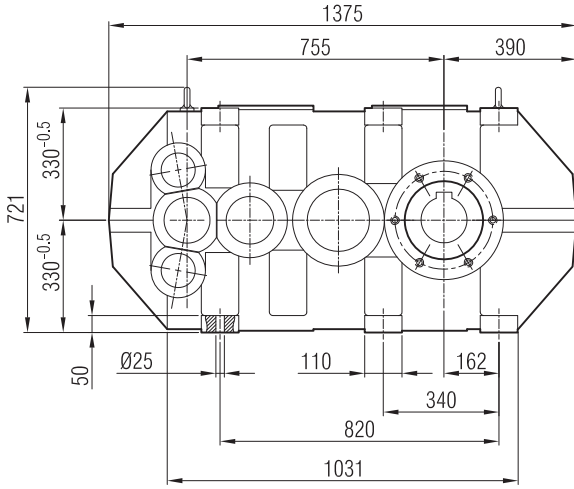

Bağlantı Pozisyonları

Mounting Positions

Bauformen

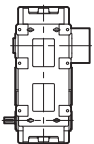

P1

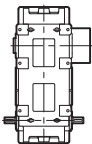

P4

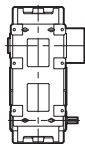

P8







Yedek Parça Listesi

General Parts List

Einzelteilliste

TİP / TYPE / TYP
A } 200

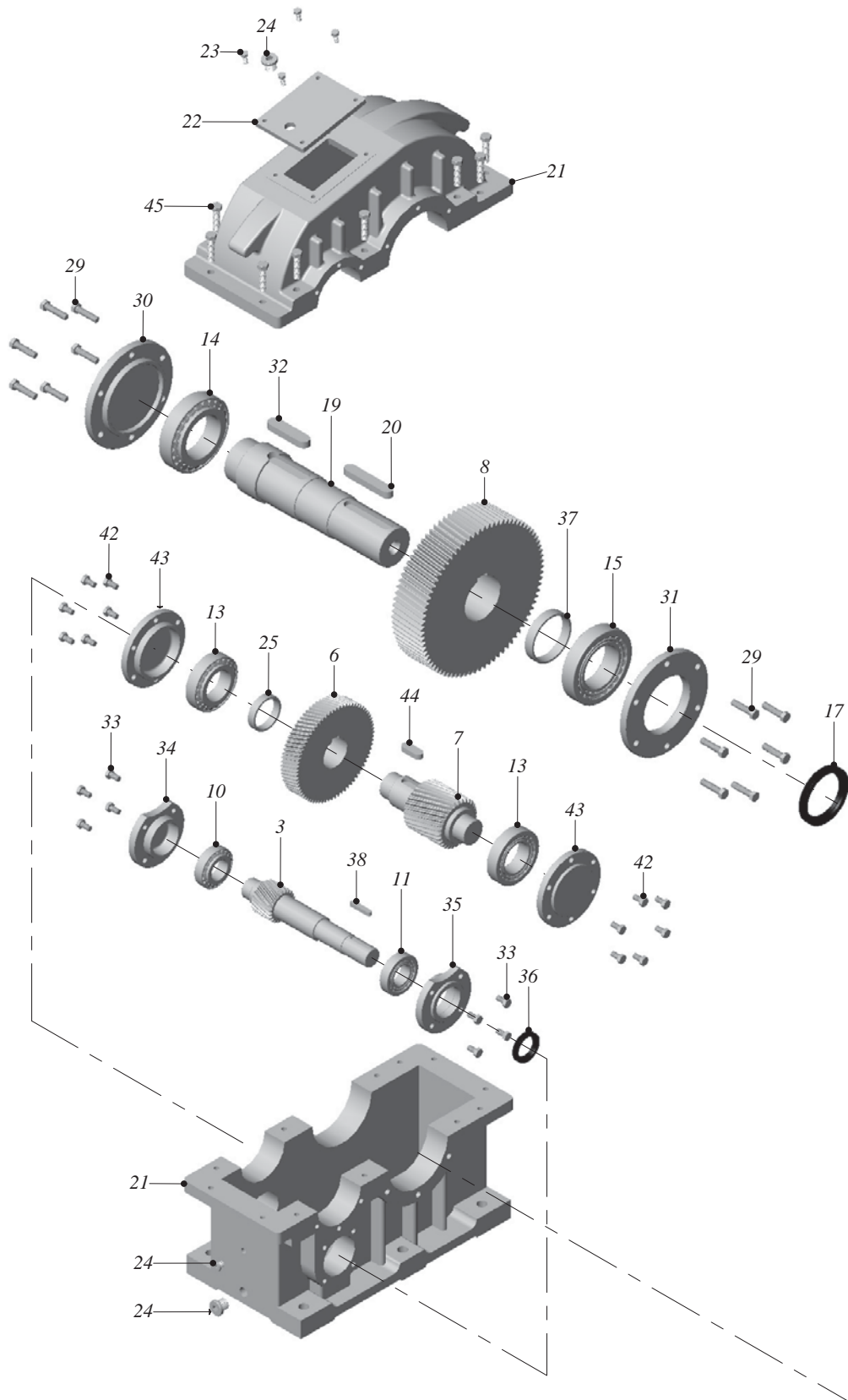



Yedek Parça Listesi

General Parts List

Einzelteilliste

TİP / TYPE / TYP

A } 200

3 - Milli Dişli Z1 (Giriş Mili)	3 - Gear Z1	3 - Ritzelwelle Z1
7 - Milli Dişli Z5	7 - Gear Z5	7 - Ritzelwelle Z5
8 - Dişli Z6	8 - Gear Z6	8 - Rad Z6
10 - Rulman	10 - Bearing	10 - Lager
11 - Rulman	11 - Bearing	11 - Lager
13 - Rulman	13 - Bearing	13 - Lager
14 - Rulman	14 - Bearing	14 - Lager
15 - Rulman	15 - Bearing	15 - Lager
17 - Keçe	17 - Seal	17 - Wellendichtring
19 - Çıkış Mili	19 - Output Shaft	19 - Abtriebswelle
20 - Kama	20 - Key	20 - Passfeder
21 - Gövde	21 - Gear Case	21 - Getriebegehäuse
22 - Kapak	22 - Cover	22 - Deckel
23 - Cıvata	23 - Bolt	23 - Sechskantschraube
24 - Yağ Tapası	24 - Oil Plug	24 - Ölschraube
25 - Burç	25 - Spacer	25 - Stützscheibe
29 - Cıvata	29 - Bolt	29 - Sechskantschraube
30 - Rulman Baskı Kapağı	30 - Bearing Cover	30 - Lagerdeckel
31 - Keçe Kapağı	31 - Seal Cover	31 - Dichtringflansch
32 - Kama	32 - Key	32 - Passfeder
33 - Cıvata	33 - Bolt	33 - Sechskantschraube
34 - Rulman Baskı Kapağı	34 - Bearing Cover	34 - Lagerdeckel
35 - Keçe Kapağı	35 - Seal Cover	35 - Dichtringflansch
36 - Keçe	36 - Seal	36 - Wellendichtring
37 - Burç	37 - Spacer	37 - Stützscheibe
38 - Kama	38 - Key	38 - Passfeder
42 - Cıvata	42 - Bolt	42 - Sechskantschraube
43 - Rulman Baskı Kapağı	43 - Bearing Cover	43 - Lagerdeckel
25 - Burç	25 - Spacer	25 - Stützscheibe
45 - Cıvata	45 - Bolt	45 - Sechskantschraube



Yedek Parça Listesi

General Parts List

Einzelteilliste

TİP / TYPE / TYP
2A } 200

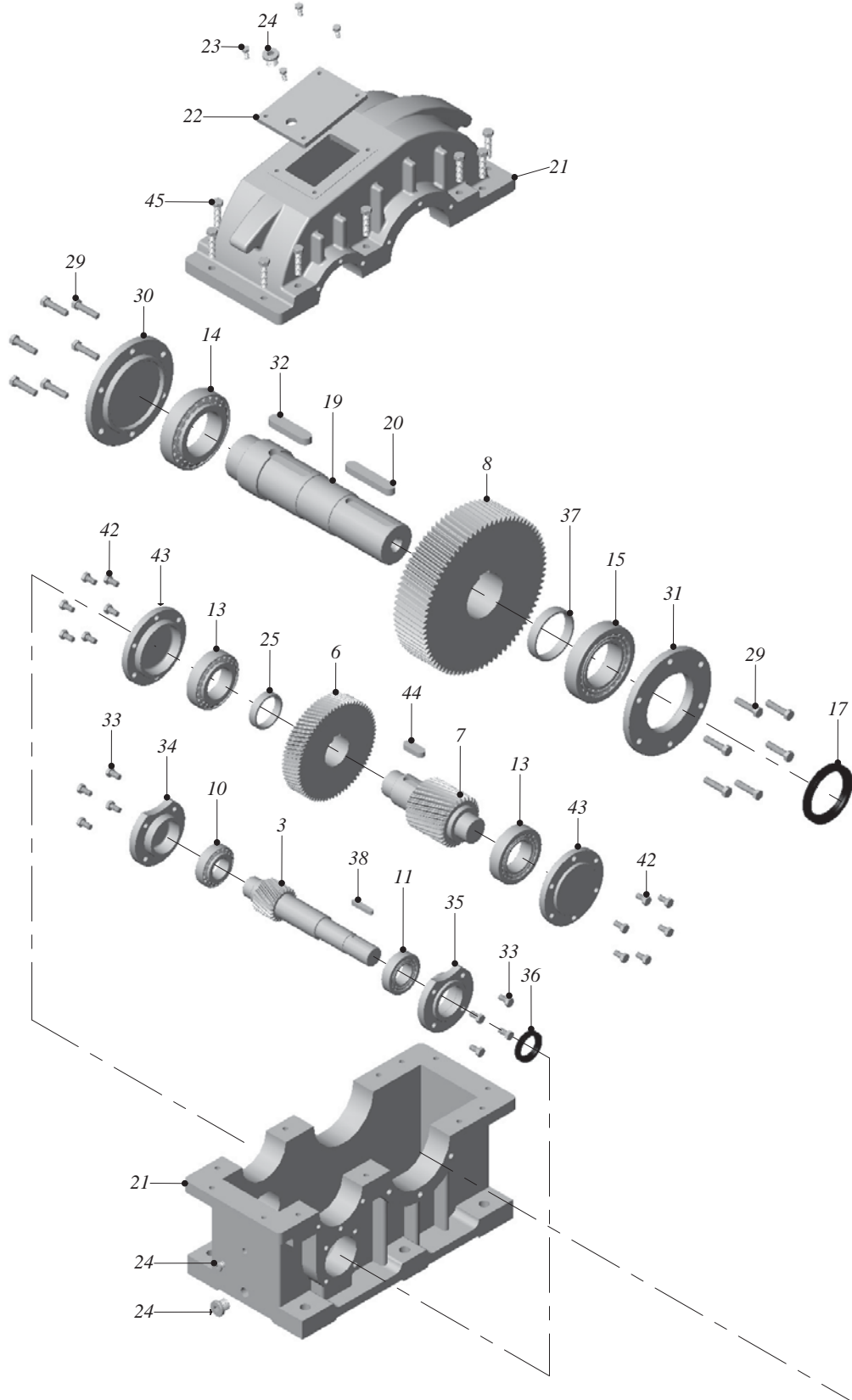



Yedek Parça Listesi

General Parts List

Einzelteilliste

TİP / TYPE / TYP

2A } 200

3 - Milli Dişli Z1 (Giriş Mili)	3 - Gear Z1	3 - Ritzelwelle Z1
6 - Dişli Z4	6 - Gear Z4	6 - Rad Z4
7 - Milli Dişli Z5	7 - Gear Z5	7 - Ritzelwelle Z5
8 - Dişli Z6	8 - Gear Z6	8 - Rad Z6
10 - Rulman	10 - Bearing	10 - Lager
11 - Rulman	11 - Bearing	11 - Lager
13 - Rulman	13 - Bearing	13 - Lager
14 - Rulman	14 - Bearing	14 - Lager
15 - Rulman	15 - Bearing	15 - Lager
17 - Keçe	17 - Seal	17 - Wellendichtring
19 - Çıkış Mili	19 - Output Shaft	19 - Abtriebswelle
20 - Kama	20 - Key	20 - Passfeder
21 - Gövde	21 - Gear Case	21 - Getriebegehäuse
22 - Kapak	22 - Cover	22 - Deckel
23 - Cıvata	23 - Bolt	23 - Sechskantschraube
24 - Yağ Tapası	24 - Oil Plug	24 - Ölschraube
25 - Burç	25 - Spacer	25 - Stützscheibe
29 - Cıvata	29 - Bolt	29 - Sechskantschraube
30 - Rulman Baskı Kapağı	30 - Bearing Cover	30 - Lagerdeckel
31 - Keçe Kapağı	31 - Seal Cover	31 - Dichtringflansch
32 - Kama	32 - Key	32 - Passfeder
33 - Cıvata	33 - Bolt	33 - Sechskantschraube
34 - Rulman Baskı Kapağı	34 - Bearing Cover	34 - Lagerdeckel
35 - Keçe Kapağı	35 - Seal Cover	35 - Dichtringflansch
36 - Keçe	36 - Seal	36 - Wellendichtring
37 - Burç	37 - Spacer	37 - Stützscheibe
38 - Kama	38 - Key	38 - Passfeder
42 - Cıvata	42 - Bolt	42 - Sechskantschraube
43 - Rulman Baskı Kapağı	43 - Bearing Cover	43 - Lagerdeckel
25 - Burç	25 - Spacer	25 - Stützscheibe
45 - Cıvata	45 - Bolt	45 - Sechskantschraube





Yedek Parça Listesi

General Parts List

Einzelteilliste

TİP / TYPE / TYP

2A } 180-225-275-350-430-501

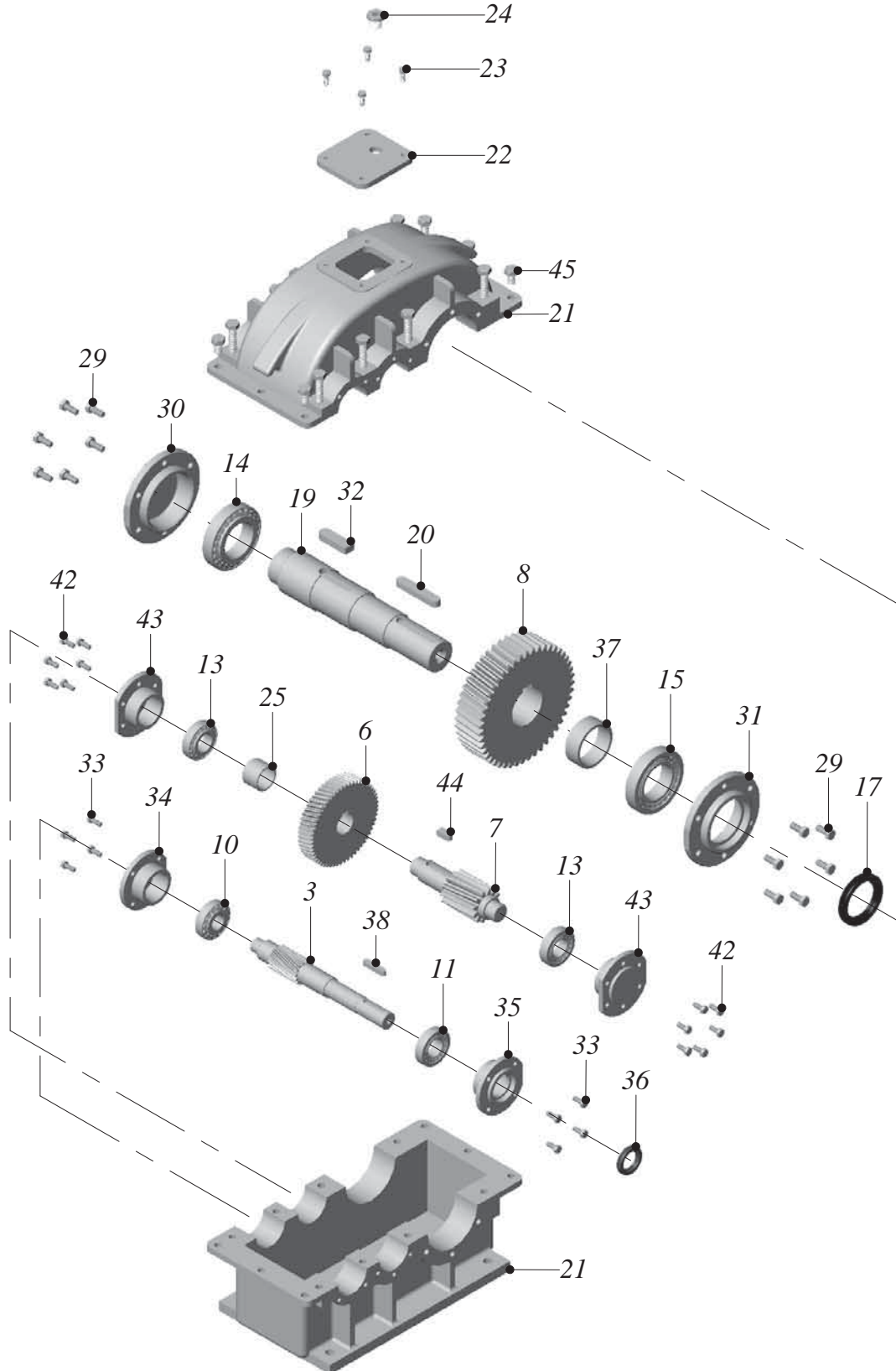



Yedek Parça Listesi

General Parts List

Einzelteilliste

TİP / TYPE / TYP

2A } 180-225-275-350-430-501

3 - Milli Dişli Z1 (Giriş Mili)	3 - Gear Z1	3 - Ritzelwelle Z1
6 - Dişli Z4	6 - Gear Z4	6 - Rad Z4
7 - Milli Dişli Z5	7 - Gear Z5	7 - Ritzelwelle Z5
8 - Dişli Z6	8 - Gear Z6	8 - Rad Z6
10 - Rulman	10 - Bearing	10 - Lager
11 - Rulman	11 - Bearing	11 - Lager
13 - Rulman	13 - Bearing	13 - Lager
14 - Rulman	14 - Bearing	14 - Lager
15 - Rulman	15 - Bearing	15 - Lager
17 - Keçe	17 - Seal	17 - Wellendichtring
19 - Çıkış Mili	19 - Output Shaft	19 - Abtriebswelle
20 - Kama	20 - Key	20 - Passfeder
21 - Gövde	21 - Gear Case	21 - Getriebegehäuse
22 - Kapak	22 - Cover	22 - Deckel
23 - Cıvata	23 - Bolt	23 - Sechskantschraube
24 - Yağ Tapası	24 - Oil Plug	24 - Ölschraube
25 - Burç	25 - Spacer	25 - Stützscheibe
29 - Cıvata	29 - Bolt	29 - Sechskantschraube
30 - Rulman Baskı Kapağı	30 - Bearing Cover	30 - Lagerdeckel
31 - Keçe Kapağı	31 - Seal Cover	31 - Dichtringflansch
32 - Kama	32 - Key	32 - Passfeder
33 - Cıvata	33 - Bolt	33 - Sechskantschraube
34 - Rulman Baskı Kapağı	34 - Bearing Cover	34 - Lagerdeckel
35 - Keçe Kapağı	35 - Seal Cover	35 - Dichtringflansch
36 - Keçe	36 - Seal	36 - Wellendichtring
37 - Burç	37 - Spacer	37 - Stützscheibe
38 - Kama	38 - Key	38 - Passfeder
42 - Cıvata	42 - Bolt	42 - Sechskantschraube
43 - Rulman Baskı Kapağı	43 - Bearing Cover	43 - Lagerdeckel
44 - Kama	44 - Key	44 - Passfeder
45 - Cıvata	45 - Bolt	45 - Sechskantschraube



Yedek Parça Listesi

General Parts List

Einzelteilliste

TİP / TYPE / TYP
3A } 430 - 501

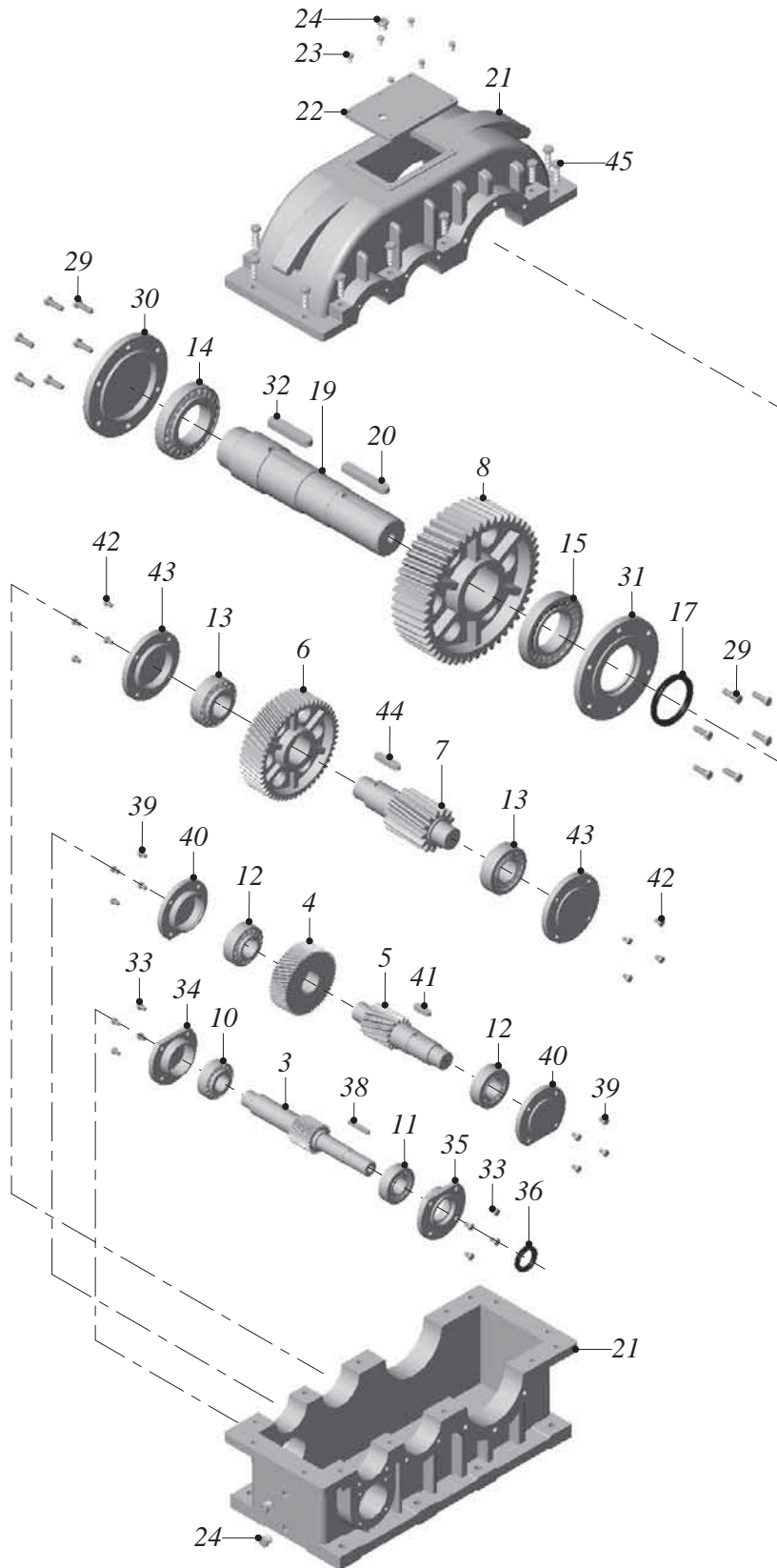



Yedek Parça Listesi

General Parts List

Einzelteilliste

TİP / TYPE / TYP

3A } 430-501

3 - Milli Dişli Z1 (Giriş Mili)	3 - Gear Z1	3 - Ritzelwelle Z1
4 - Dişli Z2	4 - Gear Z2	4 - Rad Z2
5 - Milli Dişli Z3	5 - Gear Z3	5 - Ritzelwelle Z3
6 - Dişli Z4	6 - Gear Z4	6 - Rad Z4
7 - Milli Dişli Z5	7 - Gear Z5	7 - Ritzelwelle Z5
8 - Dişli Z6	8 - Gear Z6	8 - Rad Z6
10 - Rulman	10 - Bearing	10 - Lager
11 - Rulman	11 - Bearing	11 - Lager
12 - Rulman	12 - Bearing	12 - Lager
13 - Rulman	13 - Bearing	13 - Lager
14 - Rulman	14 - Bearing	14 - Lager
15 - Rulman	15 - Bearing	15 - Lager
17 - Keçe	17 - Seal	17 - Wellendichtring
19 - Çıkış Mili	19 - Output Shaft	19 - Abtriebswelle
20 - Kama	20 - Key	20 - Passfeder
21 - Gövde	21 - Gear Case	21 - Getriebegehäuse
22 - Kapak	22 - Cover	22 - Deckel
23 - Cıvata	23 - Bolt	23 - Sechskantschraube
24 - Yağ Tapası	24 - Oil Plug	24 - Ölschraube
29 - Cıvata	29 - Bolt	29 - Sechskantschraube
30 - Rulman Baskı Kapağı	30 - Bearing Cover	30 - Lagerdeckel
31 - Keçe Kapağı	31 - Seal Cover	31 - Dichtringflansch
32 - Kama	32 - Key	32 - Passfeder
33 - Cıvata	33 - Bolt	33 - Sechskantschraube
34 - Rulman Baskı Kapağı	34 - Bearing Cover	34 - Lagerdeckel
35 - Keçe Kapağı	35 - Seal Cover	35 - Dichtringflansch
36 - Keçe	36 - Seal	36 - Wellendichtring
38 - Kama	38 - Key	38 - Passfeder
39 - Cıvata	39 - Bolt	39 - Sechskantschraube
40 - Rulman Baskı Kapağı	40 - Bearing Cover	40 - Lagerdeckel
41 - Kama	41 - Key	41 - Passfeder
42 - Cıvata	42 - Bolt	42 - Sechskantschraube
43 - Rulman Baskı Kapağı	43 - Bearing Cover	43 - Lagerdeckel
44 - Kama	44 - Key	44 - Passfeder
45 - Cıvata	45 - Bolt	45 - Sechskantschraube



Yedek Parça Listesi

General Parts List

Einzelteilliste

TİP / TYPE / TYP
3A } 750

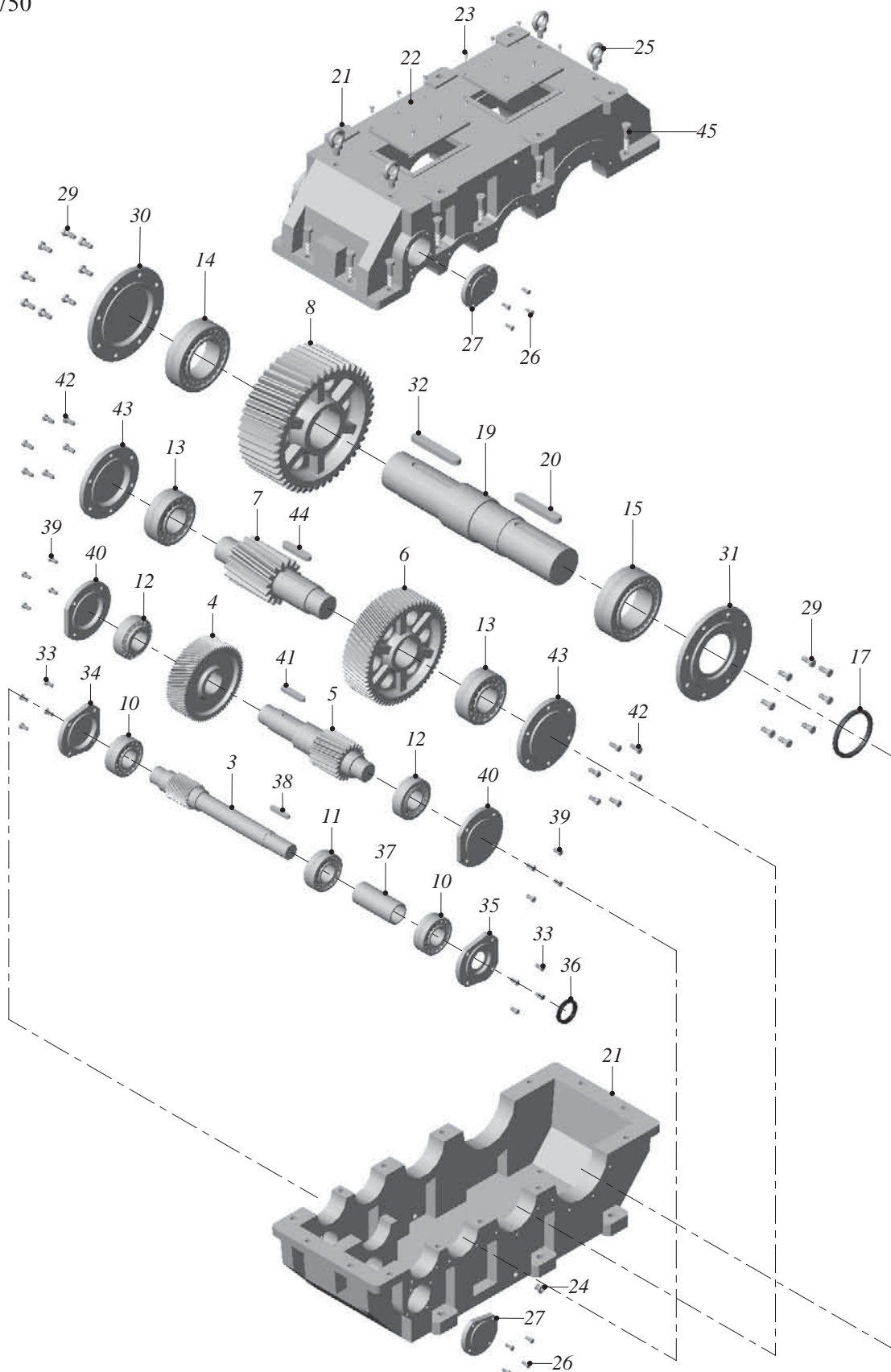

Yedek Parça Listesi
General Parts List
Einzelteilliste
TİP / TYPE / TYP
3A } 750

3 - Milli Dişli Z1 (Giriş Mili)	3 - Gear Z1	3 - Ritzelwelle Z1
4 - Dişli Z2	4 - Gear Z2	4 - Rad Z2
5 - Milli Dişli Z3	5 - Gear Z3	5 - Ritzelwelle Z3
6 - Dişli Z4	6 - Gear Z4	6 - Rad Z4
7 - Milli Dişli Z5	7 - Gear Z5	7 - Ritzelwelle Z5
8 - Dişli Z6	8 - Gear Z6	8 - Rad Z6
10 - Rulman	10 - Bearing	10 - Lager
11 - Rulman	11 - Bearing	11 - Lager
12 - Rulman	12 - Bearing	12 - Lager
13 - Rulman	13 - Bearing	13 - Lager
14 - Rulman	14 - Bearing	14 - Lager
15 - Rulman	15 - Bearing	15 - Lager
17 - Keçe	17 - Seal	17 - Wellendichtring
19 - Çıkış Mili	19 - Output Shaft	19 - Abtriebswelle
20 - Kama	20 - Key	20 - Passfeder
21 - Gövde	21 - Gear Case	21 - Getriebegehäuse
22 - Kapak	22 - Cover	22 - Deckel
23 - Cıvata	23 - Bolt	23 - Sechskantschraube
24 - Yağ Tapası	24 - Oil Plug	24 - Ölschraube
25 - Taşıma Kancası	25 - Lifting Eye Bolt	25 - Ringschraube
26 - Cıvata	26 - Bolt	26 - Sechskantschraube
27 - Rulman Baskı Kapağı	27 - Bearing Cover	27 - Lagerdeckel
29 - Cıvata	29 - Bolt	29 - Sechskantschraube
30 - Rulman Baskı Kapağı	30 - Bearing Cover	30 - Lagerdeckel
31 - Keçe Kapağı	31 - Seal Cover	31 - Dichtringflansch
32 - Kama	32 - Key	32 - Passfeder
33 - Cıvata	33 - Bolt	33 - Sechskantschraube
34 - Rulman Baskı Kapağı	34 - Bearing Cover	34 - Lagerdeckel
35 - Keçe Kapağı	35 - Seal Cover	35 - Dichtringflansch
36 - Keçe	36 - Seal	36 - Wellendichtring
37 - Burç	37 - Spacer	37 - Stützscheibe
38 - Kama	38 - Key	38 - Passfeder
39 - Cıvata	39 - Bolt	39 - Sechskantschraube
40 - Rulman Baskı Kapağı	40 - Bearing Cover	40 - Lagerdeckel
41 - Kama	41 - Key	41 - Passfeder
42 - Cıvata	42 - Bolt	42 - Sechskantschraube
43 - Rulman Baskı Kapağı	43 - Bearing Cover	43 - Lagerdeckel
44 - Kama	44 - Key	44 - Passfeder
45 - Cıvata	45 - Bolt	45 - Sechskantschraube



Yedek Parça Listesi

General Parts List

Einzelteilliste

TİP / TYPE / TYP
4A } 750

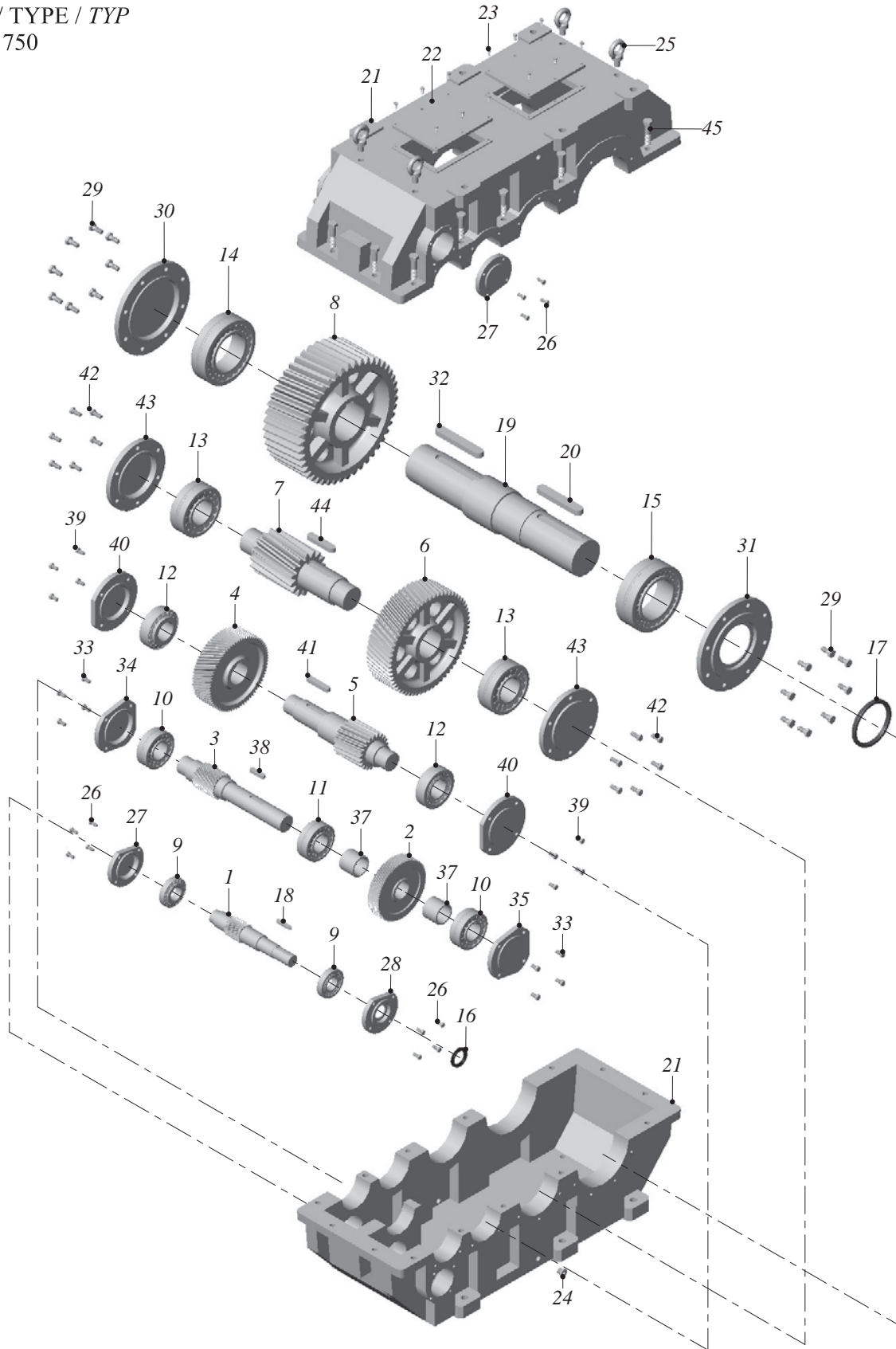

Yedek Parça Listesi
General Parts List
Einzelteilliste
TİP / TYPE / TYP
4A } 750

1 - Dişli Z1 (Giriş Mili)	1 - Gear Z1	1 - Rad Z1
2 - Dişli Z2	2 - Gear Z2	2 - Rad Z2
3 - Milli Dişli Z3	3 - Gear Z3	3 - Ritzelwelle Z3
4 - Dişli Z4	4 - Gear Z4	4 - Rad Z4
5 - Milli Dişli Z5	5 - Gear Z5	5 - Ritzelwelle Z5
6 - Dişli Z6	6 - Gear Z6	6 - Rad Z6
7 - Milli Dişli Z7	7 - Gear Z7	7 - Ritzelwelle Z7
8 - Dişli Z8	8 - Gear Z8	8 - Rad Z8
9 - Rulman	9 - Bearing	9 - Lager
10 - Rulman	10 - Bearing	10 - Lager
11 - Rulman	11 - Bearing	11 - Lager
12 - Rulman	12 - Bearing	12 - Lager
13 - Rulman	13 - Bearing	13 - Lager
14 - Rulman	14 - Bearing	14 - Lager
15 - Rulman	15 - Bearing	15 - Lager
16 - Keçe	16 - Seal	16 - Wellendichtring
17 - Keçe	17 - Seal	17 - Wellendichtring
18 - Kama	18 - Key	18 - Passfeder
19 - Çıkış Mili	19 - Output Shaft	19 - Abtriebswelle
20 - Kama	20 - Key	20 - Passfeder
21 - Gövde	21 - Gear Case	21 - Getriebegehäuse
22 - Kapak	22 - Cover	22 - Deckel
23 - Cıvata	23 - Bolt	23 - Sechskantschraube
24 - Yağ Tapası	24 - Oil Plug	24 - Ölschraube
25 - Taşıma Kancası	25 - Lifting Eye Bolt	25 - Ringschraube
26 - Cıvata	26 - Bolt	26 - Sechskantschraube
27 - Rulman Baskı Kapağı	27 - Bearing Cover	27 - Lagerdeckel
28 - Keçe Kapağı	28 - Seal Cover	28 - Dichtringflansch
29 - Cıvata	29 - Bolt	29 - Sechskantschraube
30 - Rulman Baskı Kapağı	30 - Bearing Cover	30 - Lagerdeckel
31 - Keçe Kapağı	31 - Seal Cover	31 - Dichtringflansch
32 - Kama	32 - Key	32 - Passfeder
33 - Cıvata	33 - Bolt	33 - Sechskantschraube
34 - Rulman Baskı Kapağı	34 - Bearing Cover	34 - Lagerdeckel
35 - Rulman Baskı Kapağı	35 - Bearing Cover	35 - Lagerdeckel
37 - Burç	37 - Spacer	37 - Stützscheibe
38 - Kama	38 - Key	38 - Passfeder
39 - Cıvata	39 - Bolt	39 - Sechskantschraube
40 - Rulman Baskı Kapağı	40 - Bearing Cover	40 - Lagerdeckel
41 - Kama	41 - Key	41 - Passfeder
42 - Cıvata	42 - Bolt	42 - Sechskantschraube
43 - Rulman Baskı Kapağı	43 - Bearing Cover	43 - Lagerdeckel
44 - Kama	44 - Key	44 - Passfeder
45 - Cıvata	45 - Bolt	45 - Sechskantschraube



Yedek Parça Listesi

General Parts List

Einzelteilliste

TİP / TYPE / TYP
2AE } 225-275-350-430-501

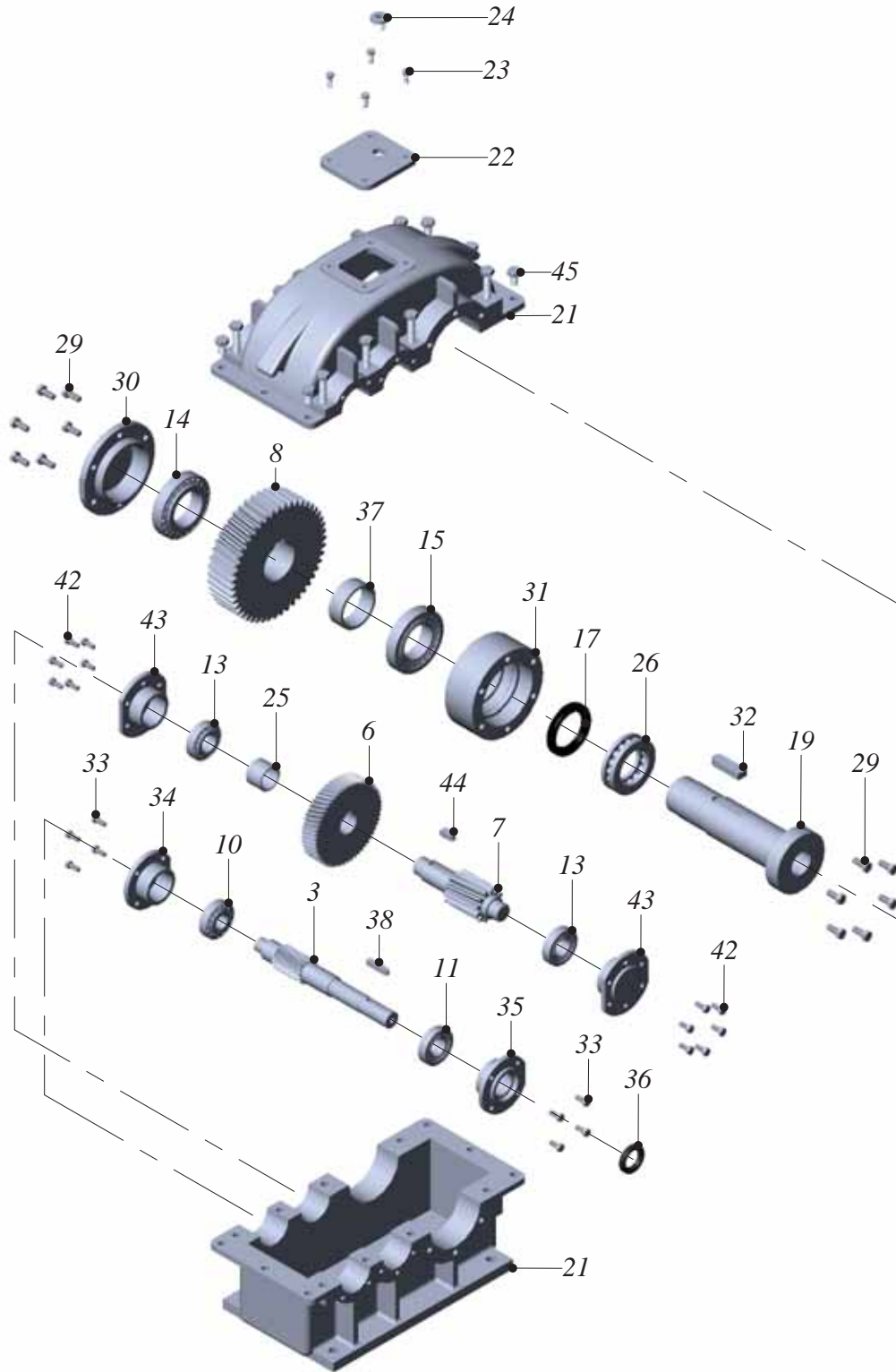



Yedek Parça Listesi

General Parts List

Einzelteilliste

TİP / TYPE / TYP

2AE } 225-275-350-430-501

3 - Milli Dişli Z1 (Giriş Mili)	3 - Gear Z1	3 - Ritzelwelle Z1
6 - Dişli Z4	6 - Gear Z4	6 - Rad Z4
7 - Milli Dişli Z5	7 - Gear Z5	7 - Ritzelwelle Z5
8 - Dişli Z6	8 - Gear Z6	8 - Rad Z6
10 - Rulman	10 - Bearing	10 - Lager
11 - Rulman	11 - Bearing	11 - Lager
13 - Rulman	13 - Bearing	13 - Lager
14 - Rulman	14 - Bearing	14 - Lager
15 - Rulman	15 - Bearing	15 - Lager
17 - Keçe	17 - Seal	17 - Wellendichtring
19 - Çıkış Mili	19 - Output Shaft	19 - Abtriebswelle
20 - Kama	20 - Key	20 - Passfeder
21 - Gövde	21 - Gear Case	21 - Getriebegehäuse
22 - Kapak	22 - Cover	22 - Deckel
23 - Cıvata	23 - Bolt	23 - Sechskantschraube
24 - Yağ Tapası	24 - Oil Plug	24 - Ölschraube
25 - Burç	25 - Spacer	25 - Stützscheibe
29 - Cıvata	29 - Bolt	29 - Sechskantschraube
30 - Rulman Baskı Kapağı	30 - Bearing Cover	30 - Lagerdeckel
31 - Extruder Rulman Gövdesi	31 - Extruder Bearing Case	31 - Extruder Lagergehäuse
32 - Kama	32 - Key	32 - Passfeder
33 - Cıvata	33 - Bolt	33 - Sechskantschraube
34 - Rulman Baskı Kapağı	34 - Bearing Cover	34 - Lagerdeckel
35 - Keçe Kapağı	35 - Seal Cover	35 - Dichtringflansch
36 - Keçe	36 - Seal	36 - Wellendichtring
37 - Burç	37 - Spacer	37 - Stützscheibe
38 - Kama	38 - Key	38 - Passfeder
42 - Cıvata	42 - Bolt	42 - Sechskantschraube
43 - Rulman Baskı Kapağı	43 - Bearing Cover	43 - Lagerdeckel
44 - Kama	44 - Key	44 - Passfeder
45 - Cıvata	45 - Bolt	45 - Sechskantschraube



TİP / TYPE / TYP

3AE } 430-501

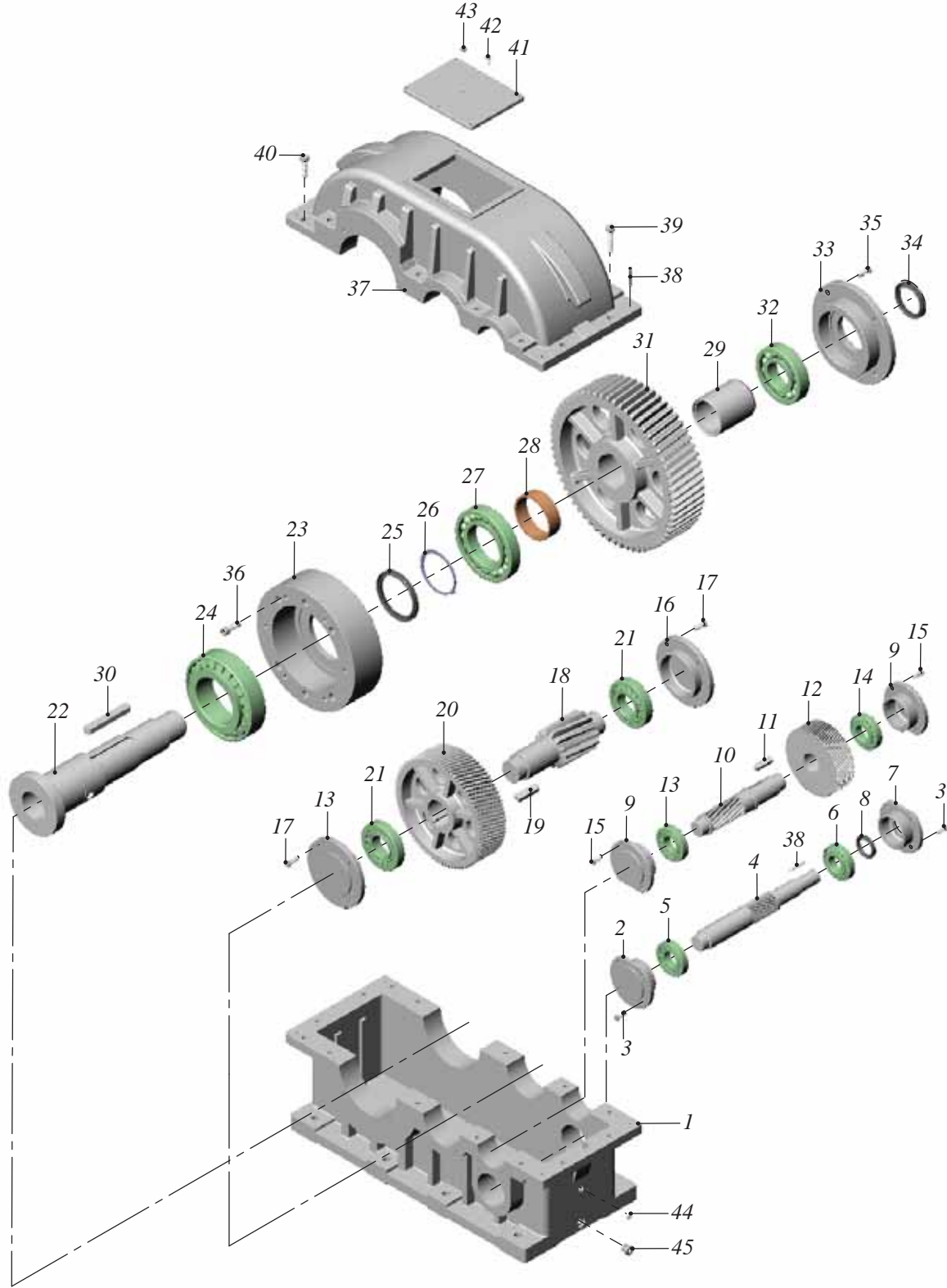

Yedek Parça Listesi
General Parts List
Einzelteilliste
TİP / TYPE / TYP
3AE } 430-501

1- Gövde	1- Gear Case	1- Getriebegehäuse
2- Rulman Baskı Kapağı	2- Bearing Cover	2- Lagerdeckel
3- Cıvata	3- Bolt	3- Sechskantschraube
4- Milli Dişli Z1	4- Gear Z1	4- Ritzelwelle Z1
5- Rulman	5- Bearing	5- Lager
6- Rulman	6- Bearing	6- Lager
7- Keçe Kapağı	7- Seal Cover	7- Dichtringflansch
8- Keçe	8- Seal	8- Wellendichtring
9- Rulman Baskı Kapağı	9- Bearing Cover	9- Lagerdeckel
10- Milli Dişli Z3	10- Gear Z3	10- Ritzelwelle Z3
11- Kama	11- Key	11- Passfeder
12- Dişli Z2	12- Gear Z2	12- Rad Z2
13- Rulman	13- Bearing	13- Lager
14- Rulman	14- Bearing	14- Lager
15- Cıvata	15- Bolt	15- Sechskantschraube
16- Rulman Baskı Kapağı	16- Bearing Cover	16- Lagerdeckel
17- Cıvata	17- Bolt	17- Sechskantschraube
18- Milli Dişli Z5	18- Gear Z5	18- Ritzelwelle Z5
19- Kama	19- Key	19- Passfeder
20- Dişli Z4	20- Gear Z4	20- Rad Z4
21- Rulman	21- Bearing	21- Lager
22- Extruder Çıkış Mili	22- Extruder Output Shaft	22- Extruder Abtriebswelle
23- Extruder Rulman Gövdesi	23- Extruder Bearing Case	23- Extruder Lagergehäuse
24- Rulman	24- Bearing	24- Lager
25- Keçe	25- Seal	25- Wellendichtring
26- Segman	26- Circlip	26- Sicherungsring
27- Rulman	27- Bearing	27- Lager
28- Bilezik	28- Spacer	28- Stützsheibe
29- Burç	29- Spacer	29- Stützsheibe
30- Kama	30- Key	30- Passfeder
31- Dişli Z6	31- Gear Z6	31- Rad Z6
32- Rulman	32- Bearing	32- Lager
33- Rulman Baskı Kapağı	33- Bearing Cover	33- Lagerdeckel
34- Keçe	34- Seal	34- Wellendichtring
35- Cıvata	35- Bolt	35- Sechskantschraube
36- Cıvata	36- Bolt	36- Sechskantschraube
37- Üst Gövde	37- Gear Case (Upper Part)	37- Getriebegehäuse (Überteil)
38- Pim	38- Pin	38- Stift
39- Cıvata	39- Bolt	39- Sechskantschraube
40- Cıvata	40- Bolt	40- Sechskantschraube
41- Üst Kapak	41- Upper Cover	41- Getriebedeckel
42- Cıvata	42- Bolt	42- Sechskantschraube
43- Havalandırma Cıvatası	43- Vent Plug	43- Entlüftungsschraube
44- Yağ Seviye Tespit Cıvatası	44- Oil Level Plug	44- Ölstandschraube
45- Yağ Boşaltma Cıvatası	45- Drain Plug	45- Verschluss-Schraube



Yedek Parça Listesi

General Parts List

Einzelteilliste

TİP / TYPE / TYP
 3AE } 750

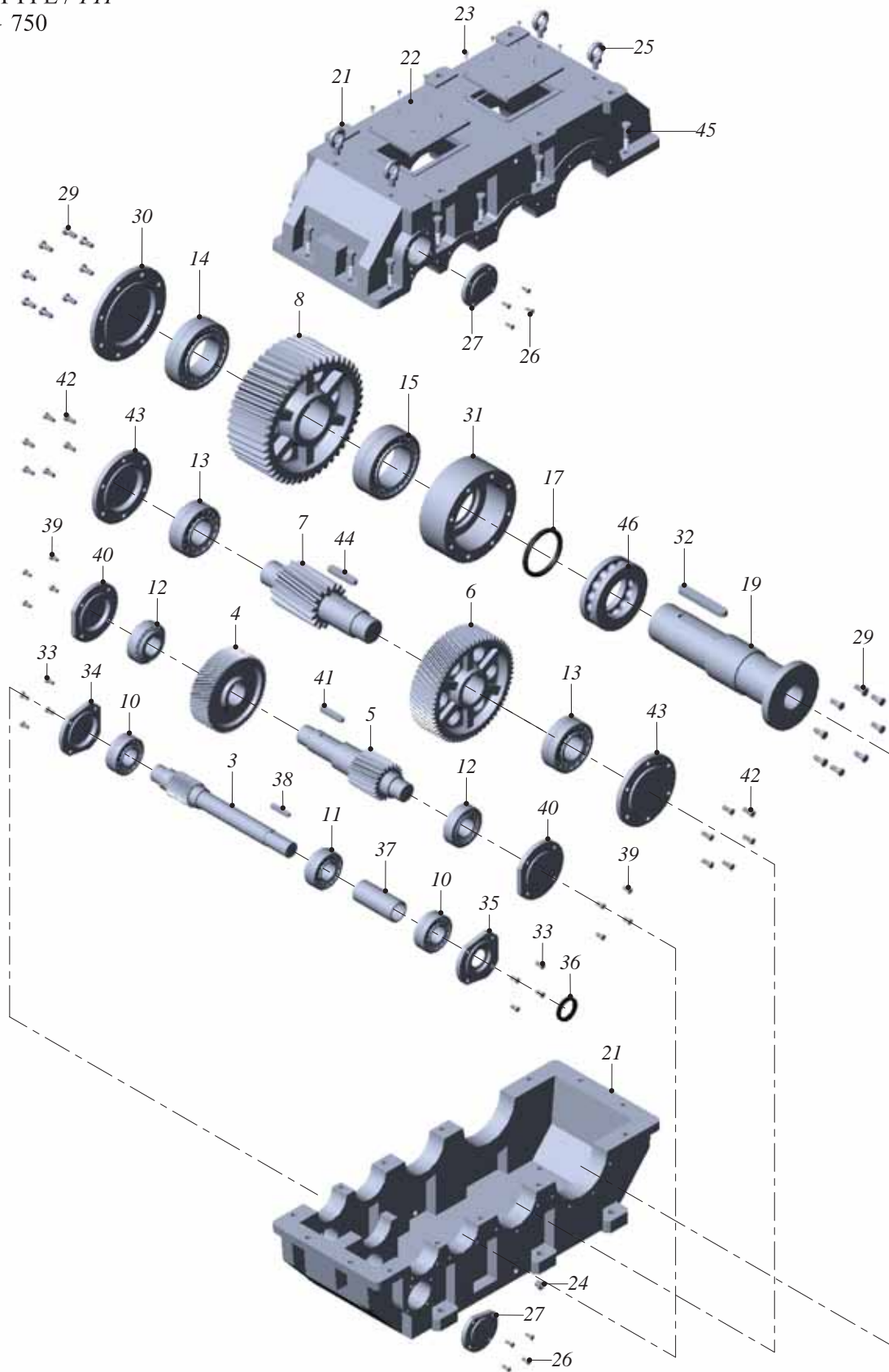

Yedek Parça Listesi
General Parts List
Einzelteilliste
TİP / TYPE / TYP

3AE } 750

3 - Milli Dişli Z1 (Giriş Mili)	3 - Gear Z1	3 - Ritzelwelle Z1
4 - Dişli Z2	4 - Gear Z2	4 - Rad Z2
5 - Milli Dişli Z3	5 - Gear Z3	5 - Ritzelwelle Z3
6 - Dişli Z4	6 - Gear Z4	6 - Rad Z4
7 - Milli Dişli Z5	7 - Gear Z5	7 - Ritzelwelle Z5
8 - Dişli Z6	8 - Gear Z6	8 - Rad Z6
10 - Rulman	10 - Bearing	10 - Lager
11 - Rulman	11 - Bearing	11 - Lager
12 - Rulman	12 - Bearing	12 - Lager
13 - Rulman	13 - Bearing	13 - Lager
14 - Rulman	14 - Bearing	14 - Lager
15 - Rulman	15 - Bearing	15 - Lager
17 - Keçe	17 - Seal	17 - Wellendichtring
19 - Çıkış Mili	19 - Output Shaft	19 - Abtriebswelle
21 - Gövde	21 - Gear Case	21 - Getriebegehäuse
22 - Kapak	22 - Cover	22 - Deckel
23 - Cıvata	23 - Bolt	23 - Sechskantschraube
24 - Yağ Tapası	24 - Oil Plug	24 - Ölschraube
25 - Taşıma Kancası	25 - Lifting Eye Bolt	25 - Ringschraube
26 - Cıvata	26 - Bolt	26 - Sechskantschraube
27 - Rulman Baskı Kapağı	27 - Bearing Cover	27 - Lagerdeckel
29 - Cıvata	29 - Bolt	29 - Sechskantschraube
30 - Rulman Baskı Kapağı	30 - Bearing Cover	30 - Lagerdeckel
31 - Extruder Rulman Gövdesi	31 - Extruder Bearing Case	31 - Extruder Lagergehäuse
32 - Kama	32 - Key	32 - Passfeder
33 - Cıvata	33 - Bolt	33 - Sechskantschraube
34 - Rulman Baskı Kapağı	34 - Bearing Cover	34 - Lagerdeckel
35 - Keçe Kapağı	35 - Seal Cover	35 - Dichtringflansch
36 - Keçe	36 - Seal	36 - Wellendichtring
37 - Burç	37 - Spacer	37 - Stützscheibe
38 - Kama	38 - Key	38 - Passfeder
39 - Cıvata	39 - Bolt	39 - Sechskantschraube
40 - Rulman Baskı Kapağı	40 - Bearing Cover	40 - Lagerdeckel
41 - Kama	41 - Key	41 - Passfeder
42 - Cıvata	42 - Bolt	42 - Sechskantschraube
43 - Rulman Baskı Kapağı	43 - Bearing Cover	43 - Lagerdeckel
44 - Kama	44 - Key	44 - Passfeder
45 - Cıvata	45 - Bolt	45 - Sechskantschraube
46 - Rulman	46 - Bearing	46 - Lager



I-MAK Turkey (Factory-Head Office):
Seyhli Mahallesi, Sanayi Caddesi No:1, 34906 Pendik / İstanbul –
Turkey Tel: +90 216 378 03 26 - Fax: +90 216 378 06 86
Web: www.imakreduktor.com / E-mail: imak@imakreduktor.com

I-MAK USA :
12610 Galveston Road, Webster, 77598 Texas, USA.
Tel: 281 480 8711 ext 200 / Fax: 281 480 8656
E-mail: sales@sipco-mls.com

www.imakreduktor.com

