



**I.Mak**®

REDÜKTÖR & VARYATÖR A.Ş.

## **Paralel Milli Redüktörler**

***Parallel Shaft Helical Geared Motor / Motoréducteurs à arbres parallèles***

**Y02**



SERIES

YP

**2021**  
TR | EN | FR

Gearboxes and Drives / Moto Réducteurs



<b>YP Serisi Redüktörlerin Genel Özellikleri</b> Descriptions and Specifications of the YP Serie / <i>Descriptions et specifications de la serie YP</i>	<b>1-2</b>
<b>Tip Tanımlamaları</b> Unit Designations / <i>Types et designations</i>	<b>3</b>
<b>Opsiyonlar</b> Options / <i>Options</i>	<b>4</b>
<b>Redüktör Bağlantı Varyasyonları</b> Mounting Options and Variations / <i>Options de montage et d'accouplement</i>	<b>5</b>
<b>Redüktör Komponent Varyasyonları</b> Gearboxes Components Variations / <i>Options et variations</i>	<b>6</b>
<b>Motor Varyasyonları</b> Mounting Options and Variations / <i>Options de montage et d'accouplement</i>	<b>7</b>
<b>Motor Komponent Varyasyonları</b> Motor's Components Variations / <i>Composant et options moteurs</i>	<b>8-9</b>
<b>Servis Faktörü</b> Service Factor / <i>Service facteur</i>	<b>10</b>
<b>Redüktör Yükleme Karakteristikleri</b> Load Characteristics of Gearboxes / <i>Types de machines et applications</i>	<b>11-14</b>
<b>Radyal Yükler</b> Overhung Loads / <i>Charges radiales</i>	<b>15-18</b>
<b>Motor İşletme Değerleri</b> Motor Performance / <i>Performance Moteurs</i>	<b>19-20</b>

<b>Frenler</b> Brakes / Freins	22
<b>Fren Seçim Tablosu</b> Brake Selection Table / Table de sélection des freins	23
<b>Lastik Takoz</b> Rubber Rings / Anneaux en caoutchouc	24
<b>Montaj Pozisyonları</b> Mounting Positions / Position de montage	25
<b>Klemens Pozisyonları</b> Position of Terminal Box / Position de la boîte à bornes	26
<b>Montaj Pozisyonları ve Yağ Miktarları</b> Mounting Positions and Oil Quantities / Positions de montage et quantités d'huiles	27-30
<b>Redüktörlerin Kontrol ve Bakımları</b> Control and Maintenance of Gearboxes / Contrôle et maintenance des réducteurs	31
<b>Redüktör Sipariş</b> Gearbox Ordering / Commandez votre réducteur	32
<b>YP Serisi Redüktörler Güç ve Devir Tabloları</b> Power Ratings and Output Speed Table for YP Series / YP Series puissances et vitesses de sorties	34-96
<b>YP Serisi Redüktörler Ölçü Sayfaları</b> Dimensions Pages / Dimensions	97-154
<b>Paralel Milli Redüktörler Yedek Parça Şeması ve Listesi</b> General Parts List / Liste des pièces détachées	155-161

# YP

SERİSİ / SERIES / SÉRIES



- Monoblok döküm gövdeli
- 9 Farklı gövde büyüklüğü
- 200 – 18000 Nm moment aralığı
- 4 – 32080 Tahvil aralığı

- Cast iron monobloc housing
- 9 Size of housing
- Torque range from 200 to 18000 Nm
- Ratio range from 4 to 32080

- *Carter monobloc en fonte*
- *9 tailles de carter*
- *Couple allant de 200 à 18000 Nm*
- *Rapport de réduction compris entre 4 et 32080*

## YP serisi redüktörlerin genel özellikleri

Helisel dişlili, paralel milli YP serileri, devamlı yükleme altında ve ağır şartlarda çalışmaya elverişli olarak dizayn edilmiş redüktörlerimizdir. Dişli malzemesi, bu redüktörlere uygun bir biçimde yüksek dereceli çelikten 16MnCr5 veya fiziksel olarak eşdeğer malzemelerden yapılmış ve taşlanmıştır. Dişli sertliği 58 HRC değerindedir.

Yüksek kalite döküm teknolojisi ile elde edilen gövde yapısı, hassas işleme teknolojisi, taşlanmış dişlileri ile, sessiz çalışan bir redüktör olarak endüstriyel pazarda yerini bulmuştur.

Kompakt gövde dizaynı sayesinde, kısıtlı alan konstruksiyonlarında rahatça montajı yapılabilmektedir. Özellikle konveyör, vinç yürütme gibi sistemlerde en çok tercih edilen tiplerdendir.

YP tip redüktörlere özel olarak tasarlanmış, montaj lastikleri ile, redüktörlerin çok kolay bir şekilde montajını gerçekleştirebilirsiniz. Moment kolu prensibi mantığında çalışacak bir sistemde, redüktör ani kalkışlara karşı korunmuş olur. Sistemsel kasma ve gerilmeler minimize edilmiş olur.

Bu redüktörlerimizi, delik milli, çıkış milli, çift yönlü çıkış milli, sıkma bilezikli ve flanşlı şekilde kullanabilirsiniz.

Ayrıca geniş gövde seçenekleri ile birçok ihtiyacınızı karşılamış olursunuz.

## Descriptions and specifications of the YP serie.

The YP Series gearboxes are specially designed for applications with heavy loads or continuous working cycle. The set of components is based on helical gears made of 16MnCr5, all gears are grinded, and finished after heat treatment to reach 58 HRC hardness.

The iron cast housing is produced under a very specific process to guarantee a high performance of the gearbox itself. The CNC process guarantees a perfect respect of the initial design and calculations to provide a noise free working. The YP serie is perfect for conveyors, hoist drives and various other applications. Available with hollow shaft, output shaft, flange, and various other options, the YP gearboxes guarantee easy installation, mounting and maintenance.

## Descriptions et spécifications de la série YP.

Spécialement conçus pour les applications à charges continue, les réducteurs de la Série YP garantissent une performance optimale. Les pignons hélicoïdaux qui composent les réducteurs de cette série sont produits à partir d'acier 16MnCr5 avec une dureté de 58 HRC après traitement.

Le carter du réducteur est produit selon un procédé très précis et un contrôle qualité poussé pour permettre une qualité supérieure. Ces différents paramètres permettent d'obtenir un réducteur au fonctionnement sans bruit et avec une vibration limitée. Les réducteurs de la série YP sont parfaitement adaptés pour des applications de convoyage ou de manutention de matériaux. Disponibles avec une large gamme d'options (Arbres creux, arbre de sortie, bride, bras d'attraction...) les réducteurs YP garantissent une grande facilité pour le montage, l'installation et l'entretien quelques soit la configuration.

**Paralel milli redüktörler**

Parallel shaft helical geared motor / *Motorréducteurs à arbres parallèles*

Kod	Tip tanımlama	Input type designation	Spécifications des types
YP...	Giriş milli - moment kolları - delik milli	Input shaft - torque arm - hollow shaft	Arbre d'entrée - bras de réaction - arbre creux
YPF...	Giriş milli - flanş montajlı - delik milli	Input shaft - flange mounted - hollow shaft	Arbre d'entrée - bride de sortie - arbre creux
YPM...	Motorlu - moment kolları - delik milli	With motor - torque arm - hollow shaft	Avec moteur - bras de réaction - arbre creux
YPFM...	Motorlu - flanş montajlı - delik milli	With motor - flange mounted - hollow shaft	Avec moteur - bride de sortie - arbre creux
YPP...	IEC giriş flanşlı - moment kolları - delik milli	IEC input flange - torque arm - hollow shaft	Bride d'entrée IEC - bras de réaction - arbre creux
YFPF...	IEC giriş flanşlı - flanş montajlı - delik milli	IEC input flange - flange mounted - hollow shaft	Bride d'entrée IEC - bride de sortie - arbre creux
YPPM...	IEC giriş flanşlı motorlu - moment kolları - delik milli	IEC input flange with motor - torque arm - hollow shaft	Bride d'entrée IEC - avec bras de réaction - arbre creux
YFPFM...	IEC giriş flanşlı motorlu - flanş montajlı - delik milli	IEC input flange with motor - flange mounted - hollow shaft	Bride d'entrée IEC - avec moteur - bride de sortie - arbre creux

**Giriş opsiyonları**

Input options / *Options d'entrée*



**YP**  
**Giriş milli**  
Solid input shaft  
*Avec arbre de sortie*



**YPM**  
**Motorlu**  
With motor  
*Avec moteur*



**YPP**  
**IEC pam flanşlı**  
IEC input flange  
*Avec bride PAM - IEC*



**YPPM**  
**IEC pam flanşlı motorlu**  
IEC input flange with motor  
*Avec bride PAM-IEC et moteur*

**Redüktör opsiyonları / Gearboxes options / Options des motoréducteurs**

Kod	Opsiyon	Options	Options
SL	Çıkış Milli	Output shaft	Arbre de sortie
FL	Çıkış flanşlı	Output flange	Bride de sortie
H	Çektirme pulu	Retaining screw washer	Epaulement ( vis de fixation )
SDL	Sıkma bilezik	Shrink disc	Frette de serrage
OC	Çıkış koruma kapağı	Output cover	Bouchon ( arbre creux )

**YP Serisi redüktörlerde flanş bağlantılı olmayan ürünlerde moment kolu standarttır.**

For all geared motors without flange, the torque arm is standard and not optional.

Les bras d'attraction sont standards pour tous les réducteurs fournis sans bride de sorties.

**Motor opsiyonları / Motor's options / Options moteurs**

Kod	Opsiyon	Options	Options
BR	Fren	Brake	Frein
BRH	Manuel kollu fren	Brake with hand release	Frein avec ouverture manuel
BD	Çift fren	Double brake	Double frein
BDH	Manuel kollu çift fren	Double brake with hand release	Double frein avec ouverture manuel
E	Enkoder	Encoder	Encoder
EMK	Elektromanyetik kavrama	Electromagnetic clutches	Disque electromagnetique
CF	Harici fan	External fan	Ventilation externe
FG	Kanopi	Canopy	Canopé
U	Fansız motor (güdük)	Without fan	Sans ventilation
M	Monofaze motor	Mono phase motor	Moteur monophasé
BS	Mekanik kilit	Backstop	Roulement anti-retour

**Çıkış opsiyonları**

Output options / Options de sortie



**YP..**  
**Delik milli**  
Hollow output shaft  
Arbre creux



**YP....SL**  
**Çıkış milli**  
Output shaft  
Arbre de sortie



**YP...FL-SL**  
**Çıkış milli - Çıkış flanşlı**  
Output shaft-Output flange  
Arbre et bride de sortie



**YP...FL**  
**Çıkış flanşlı**  
Output flange  
Bride de sortie



**Çıkış mili / Output shaft / Arbre de sortie**

Kod / Code	Varyasyon	Options	Options
111	Özel mil ölçüsü	Special shaft dimensions	Dimensions de l'arbre spécial
112	Özel mil malzemesi	Special shaft materials	Matériel de l'arbre spécial
113	Sertleştirilmiş mil	Hardened shaft	Axe durci
114	Diş çekilmiş mil	Shaft with screw	Axe à vis
115	Çoklu kama uygulaması	Shaft with multiple key	Arbre à multi clavette

**Kovan / Hollow shaft / Bride**

Kod / Code	Varyasyon	Options	Options
121	Özel kovan ölçüsü	Dimensions of special shaft	Arbre creux spécial
122	Özel kovan malzemesi	Material of special output shaft	Arbre creux en matériaux spéciaux
123	Sertleştirilmiş kovan *	Hardened steel hollow shaft	Arbre creux en acier trempé
124	Diş çekilmiş kovan**	Hollow shaft with screw	Arbre creux a vis
125	Opsiyonel kovan	Optional output shaft	Arbre creux optionnel
126	Çoklu kama uygulaması	Hollow shaft with splining	Arbre creux cannelé

**Giriş mili - pam mili / Input shaft / Bride pam**

Kod / Code	Varyasyon	Options	Options
131	Özel mil ölçüsü	Dimensions of the shaft	Dimensions de l'arbre ( Spécial )
132	Özel mil malzemesi	Material of special shaft	Matériaux de l'arbre ( Spécial )
133	Sertleştirilmiş mil	Hardened steel shaft	Arbre en acier trempé
134	Çoklu kama uygulaması	Hollow shaft with screw	Arbre creux a vis
135	Özel alın mili	Spécial input shaft	Arbre d'entrée spécial
136	Diş çekilmiş mil	Shaft with screw	Arbre de sortie avec vis

**Çıkış flanşı / Output flange / Bride de sortie**

Kod / Code	Varyasyon	Options	Options
141	Özel flanş ölçüsü	Dimensions of special output flange	Dimensions de la bride de sortie (Spéciale)
142	Özel flanş malzemesi	Material of special output flange	Matériaux de la bride de sortie (Spéciale)
143	Opsiyonel flanş	Optional output flange	Bride de sortie optionnelle
144	Standart dışı flanş*	Special output flange	Bride d'entrée spéciale

\* İstenilen değişiklik ürünün standart flanşı üzerinde yapılamayıp yeni bir flanş tasarlanması durumudur. / In the case your configuration require the production of a special flange / Dans le cas où la configuration de votre application requiert une bride d'entrée spéciale.

**Giriş flanşı / Input flange / Bride d'entrée**

Kod / Code	Varyasyon	Options	Options
151	Özel flanş ölçüsü	Special input flange	Bride d'entrée ( Spéciale )
152	Özel flanş malzemesi	Material of special input flange	Matériaux de la bride d'entrée ( spéciale )
153	Standart dışı flanş*	Special output shaft	Bride de sortie spéciale

\* İstenilen değişiklik ürünün standart flanşı üzerinde yapılamayıp yeni bir flanş tasarlanması durumudur. / In the case your configuration require the production of a special flange / Dans le cas où la configuration de votre application requiert une bride de sortie spéciale.

**Yağ / Oil / Huiles**

Kod / Code	Varyasyon	Options	Options
211	Sentetik yağ VG 220 (SHC 630)	Synthetic oil VG 220 ( SHC 630 )	Huile synthétique VG 220 ( SHC 630 )
212	Gıda uyumlu yağ VG 220 (CIBUS 220)	Food compatible oil VG 220 ( CIBUS 220 )	Huile pour industrie agroalimentaire VG 220 (CIBUS 220)
213	-40C° Uyumlu yağ VG 220 (SHC 630)	Cold resistant oil -40C° VG 220 ( SHC 630 )	Huile base température -40C° VG220 ( SHC 630 )

**Keçe-tapa / Seal-cover / Joint- bouchon**

Kod / Code	Varyasyon	Options	Options
221	Özel ölçü keçe	Dimensions of special seal	Dimensions du joint (Spécial)
222	Özel ölçü tapa	Dimensions of special cover	Dimensions du bouchon ( Spécial )
223	Özel marka keçe	Special brand of seal	Marque du joint ( Spécial )
224	Özel marka tapa	Special brand of cover	Marque du bouchon ( Spécial )
225	Viton keçe	Viton seal	Joint en viton
226	Özel tip keçe uygulaması	Special configuration of seal	Configuration spéciale du joint
227	Toz kapağı	Dust cover	Bouchon anti-poussière

**Rulman / Bearing / Roulement**

Kod / Code	Varyasyon	Options	Options
231	Güçlendirilmiş çıkış rulmanı	Reinforced output bearing	Roulement renforcé ( Sortie )
232	Güçlendirilmiş giriş rulmanı	Reinforced input bearing	Roulement renforcée ( Entrée )
233	Özel marka rulman	Special brand of bearing	Marque du roulement ( Spécial )
234	Özel ölçü rulman	Special dimensions of bearing	Dimensions du roulement ( Spécial )
235	Mekanik kilit CW*	Backstop bearing ( CW )	Roulement anti-retour ( CW )
236	Mekanik kilit CCW*	Backstop bearing ( CCW )	Roulement anti-retour ( CCW )

\* İRO ve YP serileri için geçerlidir, diğer serilerde motora uygulanmaktadır. / Available in YP and IRO Series, the other series are equipped with backstop bearings at motor side / Disponible pour les séries YP et IRO, les autres séries sont équipés de roulement anti-retour placés sur le moteur.

**Gövde / Housing / Carter**

Kod / Code	Varyasyon	Options	Options
241	Özel işlenmiş gövde	Special housing	Carter spéciale
242	Özel malzeme	Special housing materials	Carter avec matériaux spéciaux

**Boya / Paint / Peinture**

Kod / Code	Varyasyon	Options	Options
251	Özel renk boya	Special paint color	Couleur spéciale
252	Özel tip boya	Special paint type	Type de peinture spéciale
253	Epoksi boya	Epoxy paint	Peinture epoxy
254	Akrilik boya (dış ortam)	Acrylic paint	Peinture acrylique (Environnement extérieur)
255	Su bazlı boya	Water based paint	Peinture à base d'eau
256	Antikorozyon boya	Anti-corrosion paint	Peinture anti-corrosion

**Dişli / Gears / Pignons**

Kod / Code	Varyasyon	Options	Options
261*	Özel imalat dişli	Special gear	Pignons spéciaux
262	Katalog dışı tahvil	Gear ratio ( Catalogue )	Rapport de réduction des pignons (Catalogue)

\* 261 kodu, 262 yi kapsamaktadır. / 261 and 262 codes are equivalent / Les codes 261 et 262 sont équivalents

**Voltaj - Frekans / Voltage and frequency / Voltage et fréquence**

Kod / Code	Varyasyon	Options	Options
311	Özel voltaj motor	Special voltage	Voltage spécial
312	Özel frekans motor	Special frequency	Fréquence spéciale

\*400 V 50 Hz dışı tüm sarımlar standart dışı kabul edilir. / 400 V 50 Hz are considered as standard / 400 V 50 Hz sont les normes standards

**Koruma sınıfı / IP Classification / Classification IP**

Kod / Code	Varyasyon	Options	Options
321	IP 54	IP 54	IP 54
322	IP 56	IP 56	IP 56
323	IP 65	IP 65	IP 65
324	IP 66	IP 66	IP 66

IP 55 Standart kabul edilir / IP 55 is our standard / IP 55 étant la classe standard

**İzolasyon sınıfı / Isolation class / Classe d'isolations**

Kod / Code	Varyasyon	Options	Options
331	B sınıfı	B - class	Classe - B
332	H sınıfı	H - class	Classe - H

\* F izolasyon sınıfı standart kabul edilir. / F class is accepted as a standard / La classe F étant la norme d'isolation standard

\* 0 C° ile 40 C° aralığı dışındaki ortam sıcaklıkları için fabrikaya danışınız / Adapted for outside environment with temperature in between 0 C° and 40 C° / Adapté aux environnements extérieurs avec une température comprises entre 0° C et 40° C

**Rulman / Bearing / Roulement**

Kod / Code	Varyasyon	Options	Options
341	Sıcak ortam rulmanı*	Bearing for hot environment	Roulement pour environnement a températures élevées
342	Soğuk ortam rulmanı*	Bearing for cold environment	Roulement pour environnement a températures négatives
343	İzole rulman	Isolated bearing	Roulement isolé
344	Gresörlük	Bearing with greasing nipples	Roulement avec graisseurs
345	Mekanik kilit CW	Backstop bearing ( CW )	Roulement anti-retour ( CW )
346	Mekanik kilit CCW	Backstop bearing ( CCW )	Roulement anti-retou ( CCW )

\* 0 C° ile 40 C° aralığı dışındaki ortam sıcaklıkları için fabrikaya danışınız / For outside environment with temperature out of 0C° and 40C° consult our technical team / Pour des environnements avec des température non comprises entre 0C° et 40C° consulté nos équipes techniques.

**Marka / Brand / Marque**

Kod / Code	Varyasyon	Options	Options
351	Gamak Motor	Gamak Motor	Gamak Moteur
352	Volt Elektrik Motor	Volt Motor	Volt Moteur
353	Aemot Motor	Aemot Motor	Aemot Moteur
354	Wat Motor	Wat Motor	Wat Moteur
356	Diğer	Diğer	Diğer

**Verim sınıfı / Efficiency classifications / Classes d'efficience énergétique**

Kod / Code	Varyasyon	Options	Options
361	IE1	IE1	IE1
362	IE3	IE3	IE3
363	IE4	IE4	IE4

\* IE 2 verim sınıfı standart kabul edilir. / IE 2 is the standard category / IE 2 étant la norme standard

## Fren markası / Brake's brand / Marque du frein

Kod / Code	Varyasyon	Options	Options
412	EMF fren	EMF brake	Frein - EMF
413	Fatih fren	Fatih brake	Frein - Fatih
414	Diğer	Other	Autres

## Fren tipi / Type of brake / Type de frein

Kod / Code	Varyasyon	Options	Options
421	220 V soğutmalı	220 V cooler	220 V - avec refroidissement
422	24 V soğutmalı	24 V cooler	24 V - avec refroidissement
423	220 V soğutmasız*	220 V without cooler	220 V - sans refroidissement
424	24 V soğutmasız*	24 V without cooler	24 V - sans refroidissement
425	Çift balatalı fren	Double disk brake	Frein avec double disque
426	Özel tip fren	Special brake type	Type de frein spécial
427	Özel voltaj fren	Special voltage for brake	Frein avec voltage spécial

\* Soğutmasız frenlerde motor fan muhafazası bulunmamaktadır / The brake without cooling are installed without fan or cover / Les freins sans refroidissement ne sont pas équipés de couvercle ou d'hélice.

## Enkoder / Encoder / Codeur

Kod / Code	Varyasyon	Options	Options
431	HPL 100 Pulse rotary enkoder	HPL 100 Pulse rotary encoder	HPL 100 Codeur d'impulsions rotatif
432	HPL 360 Pulse rotary enkoder	HPL 360 Pulse rotary encoder	HPL 360 Codeur d'impulsions rotatif
433	HPL 500 Pulse rotary enkoder	HPL 500 Pulse rotary encoder	HPL 500 Codeur d'impulsions rotatif
434	HPL 1024 Pulse rotary enkoder	HPL 1024 Pulse rotary encoder	HPL 1024 Codeur d'impulsions rotatif
435	HPL 2048 Pulse rotary enkoder	HPL 2048 Pulse rotary encoder	HPL 2048 Codeur d'impulsions rotatif
436	HTL 1024 Pulse rotary enkoder	HTL 1024 Pulse rotary encoder	HTL 1024 Codeur d'impulsions rotatif
437	HTL 2048 Pulse rotary enkoder	HTL 2048 Pulse rotary encoder	HTL 2048 Codeur d'impulsions rotatif
438	TTL 1024 Pulse rotary enkoder	TTL 1024 Pulse rotary encoder	HTL 1024 Codeur d'impulsions rotatif
439	TTL 2048 Pulse rotary enkoder	TTL 2048 Pulse rotary encoder	TTL 2048 Codeur d'impulsions rotatif
440	Diğer	Others	Autres

\* Diğer enkoder çeşitleri için fabrikaya danışınız / For different type of encoder contact our sales team / Pour des type de codeurs différents contactez notre équipe technique

## Termistör - Isıtıcı / Thermistor and heater / Thermistatet chauffage

Kod / Code	Varyasyon	Options	Options
441	PTC X 1 termistör	PTC X 1 thermistor	PTC X 1 Thermistat
442	Bimetal termostat	Bimetallic switch	Interupteur bilame
443	Basın sensörü	Pressure sensor	Senseur pression
444	110 V sargı ısıtıcı	110 V coil heat	Bobine chauffante 110 V
445	220 V sargı ısıtıcı	220 V coil hear	Bobine chauffante 220 V
446	PT 100	PT 100	PT 100

## Harici fan / External fan / Ventilateur externe

Kod / Code	Varyasyon	Options	Options
451	24 VDC (EBM)	24 VDC (EBM)	24 VDC (EBM)
452	230 VAC (EBM)	230 VAC (EBM)	230 VAC (EBM)
453	380 VAC (EBM)	380 VAC (EBM)	380 VAC (EBM)
454	230 VAC	230 VAC	230 VAC
455	380 VAC	380 VAC	380 VAC

## Özel motorlar / Special motor / Moteur spécial

Kod / Code	Varyasyon	Options	Options
461	Servo motor*	Servo motor	Servo moteur
462	DC motor*	DC motor	Moteur DC
463	Vektör motor	Vector motor	Moteur vecteur
464	Tork motoru	Tork motor	Moteur à couple élevé
465	Hidro motor*	Hydraulic motor	Moteur hydraulique
466	Pnömatik motor*	Compressed air motor	Moteur a air comprimé
467	Ex-proof motor	Explosion proof motor	Moteur anti-explosion
468	Senkron relüktans motor	Synchronous reluctance motors	Moteur à reluctance synchrone
469	Senkron motor*	Synchronous motors	Moteurs synchrones
470	Müşteri motoru	Customer's motor	Moteur en provenance du client

\* Motorlar firmamız tarafından tedarik edilmemektedir / Our factory is not providing such motors / Moteur non fournis par notre usine  
Özel motor kodları motorların fabrikamız tarafından takıldığı durumlarda uygulanır / Motors installed in our factory / Moteur installés dans notre usine

**Servis Faktörü ( $F_s$ )**  
**Servis Faktörü = İşletme**  
**Katsayısı = ( $F_s$ )**

Redüktörlerdeki bu değer, tahrik edeceği makinenin bütün teknik ve karakteristik özelliklerine dayanma süresine bağlıdır. Genel olarak makineler yüklenme bakımından üç tip karakteristik gösterirler.

1. HAFİF YÜK (U)
2. ORTA YÜK (M)
3. AĞIR YÜK (H)

Üç değişik yükleme biçiminde çalışan, üç ayrı makinede üretilen momentler birbirine eşitte olsalar, ağır çalışan makinede daha büyük işletme katsayılı Redüktör kullanılmaktadır.

Günlük çalışma saati ise, çalışan dişli ve transmisyon elemanlarının malzeme yorulmasına maruz kalması bakımından, çalışma saatinin fazla olması halinde zararlı yönde etki eder.

Star-Stop durumuna gelince, her makinenin ilk kalkış esnasında en yüksek yüke maruz kaldığı düşünülürse tehlikeli görülür. Müteakip çalışmalarda bu daha aşağıya düşer.

Kataloğumuzda işletme katsayılarının nasıl kullanıldığının anlaşılması için bir misal ile belirtelim.

Önce tablo-1'den makinenin çalışma sahasına göre karakteristiğini belirleyelim. Makinemiz elektrik motor tahrikli ZİNCİR KOVALI EKSKAVATÖR ise yükleme durumu AĞIR' dır. ( H ) Tablo 2'den makine 24 saat çalışacağına göre minimum işletme katsayısı  $F_s = 2$  bulunur.

**Service Factor ( $F_s$ )**

Value of the service factor of a gearbox depends on all technical and characteristic specifications of a driven machine. Generally machines have three types of loading characteristics:

1. UNIFORM LOAD (U)
2. MODERATE LOAD (M)
3. HEAVY LOAD (H)

Even if the torques required by three different machines operating at three different load specifications are equal.

Gearbox of the machine operating under heavy load conditions should have greater service factor.

Daily working period has effect on gearbox elements due to the materials fatigue of working parts.

It must be taken into account that all machines are subject to the greatest load at the first start, so that the number of starts has also effect on service factor.

This is an example how to use the service factor given in the catalogue.

Load specification of machine should be determined first, from table 1 in our example, the machine is CHAIN BUCKET EXCAVATOR driven by electric motor has HEAVY load specification and daily operation time is 24 hours. So that minimum service factor  $F_s = 2$  is taken from Table 2.

**Service facteur ( $F_s$ )**

La valeur du service facteur d'un motoréducteur dépend des caractéristique de l'application. Ont distingue trois type de charges différentes

1. Charges uniformes (U)
2. Charges modérées (M)
3. Charges élevées (H)

Les spécifications des charges restent les même lorsque trois machines différentes sont soumises à des charges distinctes.

Les réducteurs utilisés dans des applications soumises à de fortes charges doivent obligatoirement avoir des services facteurs élevés.

Le nombre d'heures d'utilisations journalières a une influence directe sur l'usure des pièces et composants du réducteur.

Le réducteur est soumis à une charge maximale lors du démarrage de l'application. Le nombre d'arrêt/rédémarrage est donc à prendre en compte lors de l'analyse du service facteur.

L'exemple çı-dessous explique le processus d'analyse et de calcul du service facteur.

L'application étudiée est un excavateur a godets (Tableau 1) , le réducteur est actionné par un moteur électrique. La charge est "élevée" et la durée de fonctionnement journalière est de 24h. En se basant sur le tableau 2, le service facteur minimum requis est  $F_s = 2$

Ekskavatörler		Excavators		Excavateur	
Zincir kovalı ekskavatörler	H	Chain-Bucket excavators	H	Excavateurs à gaudets	H
Paletli yürüyüşler	H	Travelling gears (Caterpillar)	H	Convoyeur à étage	H
Ray üzerinde yürüyüşler	M	Travelling gears ( Rails )	M	Convoyeur à rails	M
Manevra mekanizmaları	U	Manoeuvring winches	U	Grues à manœuvre	U
Emiş pompaları	M	Pumps	M	Pompes	M
Kovalı çarklar	H	Bucket wheels	H	Roue à gaudets	H
Dönüş mekanizmalar	M	Slewing gears	M	Pignons rotatif	M

İnşaat Makinaları		Building Machines		Machine de Construction	
İnşaat asansörleri	U	Hoists	U	Grues de construction	U
Betoniyerler	M	Concrete mixers	M	Malaxeur à béton	M
Yol inşaat makinaları	M	Road construction machines	M	Machine de construction(routes)	M

Kaldırma ve İletme Tesisleri		Conveyor		Convoyeurs	
Zincirli konveyör	M	Through chain conveyors	M	Convoyeurs à chaines	M
Mafsal bantlı konveyörler	M	Link conveyors	M	Convoyeur à bande souple	M
Lastik bantlı konveyörler (Dökme Yükler)	U	Belt conveyors (Bulk Goods)	U	Convoyeur à bande rigide	U
Lastik bantlı elevatörler	M	Ballast elevators	M	Elevateurs à bande	M
Lastik cepli elevatörler	M	Ballast pocket elevators	M	Elevateur à poche	M
Lastik bantlı konveyörler (Parça Yükler)	M	Belt conveyors (Piece Goods)	M	Convoyeur à bande	M
Askılı konveyörler	U	Chain conveyors	U	Convoyeur à chaines	U
Yük asansörleri	M	Goods lifts	M	Élévateur à chaines	M
Kovalı elevatörler (Toz Malzeme)	U	Bucket elevators (Flour Goods)	U	Élévateur à godets (graviers)	U
Helezon konveyör	M	Screw conveyors	M	Vis d'Archimède	M
Kovalı elevatörler (Parçalı Malzeme)	M	Bucket elevators (Piece Goods)	M	Élévateurs à godets (Roches)	M
Eğik asansörler	H	Inclined hoists	H	Grues inclinées	H
Çelik bantlı konveyörler	M	Steel belt conveyors	M	Convoyeur à bande (Acier)	M
Paletli konveyörler	M	Apron conveyors	M	Convoyeurs à palettes	M

Tahrik Makinası Torque Machine Machines couplées	Günlük Çalışma Müddeti (Saat) Daily Working Period (Hour) Utilisation journalière (Heure)	Makinanın Yükleme Karakteristiği Load Characteristics of Machines Caractéristique des charges		
		Hafif Yük U Uniform Load U Charge uniforme U	Orta Yük M Moderate Load M Charge modérée M	Ağır Yük H Heavy Load H Charge élevée H
<b>Elekt. Motorlu</b> / Elect. Motor / <i>Moteurs élect.</i> <b>Türbin</b> / Turbin / <i>Turbine</i> <b>Hidrolik</b> / Hydraulic / <i>Hydraulique</i>	0.....3	0.8	1	1.5
	3....10	1	1.25	1.75
	10...24	1.25	1.5	2
<b>Pistonlu Makinalar ( 4....6 Silindir</b> Piston Machines ( 4....6 Cylindir ) <i>Machine à pistons ( 4.....6 Cylindres )</i>	0.....3	1	1.25	2
	3....10	1.25	1.5	2
	10...24	1.5	1.75	2
<b>Pistonlu Makinalar ( 1....2 Silindir)</b> Piston Machines ( 1....2 Cylindir ) <i>Machine à pistons ( 1.....2 Cylindres )</i>	0.....3	1.25	1.5	2
	3....10	1.5	1.75	2.25
	10...24	1.75	2	2.5

Kimya Endüstrisi		Chemical Industry		Industrie Chimique	
Soğutma tamburları	M	Cooling drums	M	Tambours de refroidissement	M
Karıştırıcılar	M	Mixers	M	Mixeurs	M
Çalkalayıcılar (Hafif Akışkanlar)	U	Agitators ( Liquids )	U	Agitateurs (Liquides)	U
Çalkalayıcılar (Ağır Akışkanlar)	M	Agitators ( Semi Liquids )	M	Agitateurs (Semi liquide)	M
Tambur kurutucuları	M	Drying drums	M	Tambours de séchage	M
Santrifüjler	U	Centrifuges ( Lights )	U	Centrifugeuse (Légère)	U
Santrifüjler	H	Centrifuges ( Heavy )	H	Centrifugeuse (Lourde)	H

Petrol Endüstrisi		Oil Industry		Pétrole et Hydrocarbures	
Boru hattı pompaları	M	Pipeline pumps	M	Pompes à oléoducs	M
Kuyu açma mekanizmaları	H	Rotary drilling equipment	H	Foreuse à cylindres	H

Ventilatör Ve Aspiratörler		Fans		Ventilations	
Pistonlu ventilatörler	M	Rotary piston blowers	M	Souffleurs rotatifs	M
Ventilatör ( Aksiyal ve Radyal )	U	Blowers ( Axial and Radial )	U	Souffleurs ( Axe et radial )	U
Santrifüj (türbinli) körük	H	Centrifugal	H	Centrifugeuse	H

Kauçuk Makinaları		Rubber Machines		Industrie du Caoutchouc	
Ekstruder ve kanderler	H	Extruders and calenders	H	Extrudeuse	H
Yoğurma makinaları	H	Pug mills	H	Malaxeur	H
Karıştırıcılar	M	Mixers	M	Mixeurs	M
Silindirme makinaları	H	Rolling mills	H	Presse	H

Ağaç İşleme Makinaları		Wood Working Machine		Industries Forestières	
Yontma tamburları	H	Backers	H	Presse à bois	H
Planya makinaları	M	Planing machines	M	Aplanisseuses	M
Ağaç işleme tezgahları	U	Wood working machines	U	Découpe de bois	U
Şerit testereler	H	Band saws	H	Scie	H

Yıkama Makinaları		Washing Machines		Laveuses	
Yıkama makinaları	U	Washing machines	U	Machine de lavage	U
Tamburlu kurutucular	M	Tumblers	M	Tambours	M

Tahrik Makinası Torque Machine Machines couplées	Günlük Çalışma Müddeti (Saat) Daily Working Period (Hour) Utilisation journalière (Heure)	Makinanın Yükleme Karakteristiği Load Characteristics of Machines Caractéristique des charges		
		Hafif Yük U Uniform Load U Charge uniforme U	Orta Yük M Moderate Load M Charge modérée M	Ağır Yük H Heavy Load H Charge élevée H
<b>Elekt. Motorlu</b> / Elect. Motor / Moteurs élect. <b>Türbin</b> / Turbin / Turbine <b>Hidrolik</b> / Hydraulic / Hydraulique	0....3	0.8	1	1.5
	3....10	1	1.25	1.75
	10...24	1.25	1.5	2
<b>Pistonlu Makinalar ( 4....6 Silindir</b> Piston Machines ( 4....6 Cylindir ) Machine à pistons ( 4....6 Cylindres )	0....3	1	1.25	2
	3....10	1.25	1.5	2
	10...24	1.5	1.75	2
<b>Pistonlu Makinalar ( 1....2 Silindir</b> Piston Machines ( 1....2 Cylindir ) Machine à pistons ( 1....2 Cylindres )	0....3	1.25	1.5	2
	3....10	1.5	1.75	2.25
	10...24	1.75	2	2.5



Vinç Tesisleri		Cranes		Grues	
Bom kaldırma	H	Derricking jib bomm gear	H	Bras ouvrant	H
Vinç yürüyüşleri	U	Travelling gears	U	Grues(Charriot )	U
Yük kaldırma	H	Hoist gears	H	Grues	H
Dönüş tertibatları	U	Slewing gears	U	Pignons rotatifs	U

Metal İşleme Makinaları		Metal Working Machines		Métallurgie et Acieries	
Planya makineleri	S	Planing machine	S	Aplaniseuses	S
Çekiç tokmak	S	Hammer	S	Marteau	S
Oyma makinesi	S	Engraving machine	S	Graveuses	S
Presler	H	Presses	H	Presses	H
Makaslar ( Giyotin )	M	Shears	M	Découpeuses	M
Sıcak basma presleri	H	Forging presses	H	Presse à forge	H
Takım tezgahları ( Ana Tahrir )	M	Machines tools ( Main Drives )	M	Machine outil ( Axe principal )	M
Takım tezgahları ( Yardımcı Tahrir )	U	Machines tools ( Auxiliarily Drives )	U	Machine outil ( axe secondaire )	U

Gıda Endüstri Makinaları		Food Industry Machines		Industrie Agroalimentaire	
Doldurma makinaları ( Şişe, Kavanoz vs.)	U	Filling machines ( Bottles, Contaniers.)	U	Embouteilleuse	U
Yoğurma makinaları	M	Kneading machines	M	Malaxeurs	M
Ambalaj makinaları	U	Packaging machines	U	Machine d'emballage	U
Şeker kamışı kırıcıları	M	Cane crushers	M	Presse à canne	M
Şeker kamışı kesicileri	M	Cane cutters	M	Découpeuse de canne	M
Şeker kamışı öğütücüleri	H	Cane millis	H	Broyeurs de cannes	H
Şeker pancarı kesicileri	M	Sugar beet cutters	M	Découpeuse de betteraves	M
Şeker pancarı yıkayıcıları	M	Suger beet washers	M	Laveuse à betteraves	M

Pompalar		Pumps		Pompes	
Pistonlu pompalar (Q1 / 100)	H	Piston pumps ( Q1 / 100 )	H	Pompes à piston ( Q1 / 100 )	H
Pistonlu pompalar (Q1 / 100 : 1 / 20)	M	Piston pumps ( Q1 / 100 : 1 / 20 )	M	Pompes à piston ( Q1 / 100 : 1 / 20 )	M
Türbin ( Hafif Akışkan )	U	Turbin ( Light - Liquids )	U	Turbine (Liquides légers)	U
Türbin ( Ağır Akışkan )	M	Turbin ( Semi - Liquids )	M	Turbine (Semi-liquide)	M

Tahrir Makinası Torque Machine Machines couplées	Günlük Çalışma Müddeti (Saat) Daily Working Period (Hour) Utilisation journalière (Heure)	Makinanın Yükleme Karakteristiği Load Characteristics of Machines Caractéristique des charges		
		Hafif Yük U Uniform Load U Charge uniforme U	Orta Yük M Moderate Load M Charge modérée M	Ağır Yük H Heavy Load H Charge élevée H
<b>Elekt. Motorlu</b> / Elect. Motor / Moteurs élect. <b>Türbin</b> / Turbin / Turbine <b>Hidrolik</b> / Hydrolic / Hydraulique	0....3	0.8	1	1.5
	3....10	1	1.25	1.75
	10...24	1.25	1.5	2
<b>Pistonlu Makinalar ( 4....6 Silindir</b> Piston Machines ( 4....6 Cylindir ) Machine à pistons ( 4....6 Cylindres )	0....3	1	1.25	2
	3....10	1.25	1.5	2
	10...24	1.5	1.75	2
<b>Pistonlu Makinalar ( 1....2 Silindir</b> Piston Machines ( 1....2 Cylindir ) Machine à pistons ( 1....2 Cylindres )	0....3	1.25	1.5	2
	3....10	1.5	1.75	2.25
	10...24	1.75	2	2.5

Kağıt Endüstri Makinaları		Paper Industry Machines		Industrie Papetière	
Düzeleme silindirleri	H	Glazing Cylinders	H	Cylindres appliniseurs	H
Holender	M	Hollenders	M	Holenders	M
Kağıt hamur makineleri	H	Pulpers	H	Pulpeuses	H
Kalender	H	Calender	H	Calendrier	H
Taş presler	H	Stone Presses	H	Presse	H
Vakum presler	H	Vacum Presses	H	Presse à aspiration	H
Kuru silindirler	H	Drying Cylinders	H	Cylindres de séchage	H

Taş ve Kil Makinaları		Stone and Clay Working Machines		Roches et Argiles	
Kırıcılar	H	Breakers	H	Broyeurs	H
Döner fırınlar	M	Rotary ovens	M	Four rotatifs	M
Çekiçli değirmenler	H	Hammer mills	H	Broyeux à marteaux	H
Bilyalı değirmenler	H	Ball mills	H	Broyeurs à billes	H
Çarpmalı öğütücüler	H	Beater mills	H	Broyeux à percussions	H
Tuğla presleri	H	Brick presses	H	Presse à pavès	H

Tekstil Makinaları		Textile Machines		Industrie du Textile	
Sargı makinaları ( Q1 / 100 )	M	Batchers ( Q1 / 100 )	M	Machines d'emballages	M
Basma ve boyama mak.	M	Printing and dyeing machines	M	Presse et imprimante	M
Dokuma tezgahları	M	Looms	M	Tisseuse	M

Kompresörler		Compressors		Compresseurs	
Turbo kompresör	M	Turbo compressors	M	Turbocompresseurs	M

Silindirme ve Çekme Tesisleri		Metal Rolling Mills		Acieries	
Sac kesme makineleri	H	Sheet metal cutting machines	H	Découpeuses	H
Hız ayarlı silindirler	M	Roller adjustment drivers	M	Ajusteuse à presses	M
Çubuk kesme makinaları	H	Billet shears	H	Scies	H
Kabuk sıyırma makinaları	H	Descaling machines	H	Eplucheuse	H
Tel çekme tesisleri	M	Wire drawing machines	M	Enrouleuses	M
Soğuk çekme tesisleri	H	Cooling beds	H	Bande de refroidissements	H
Rulolu nakil ( Hafif )	M	Roller tables ( Lights )	M	Enrouleuses ( légères )	M
Rulolu nakil ( Ağır )	H	Roller tables ( Heavy )	H	Enrouleuses ( lourdes )	H
Silindir haddeme	H	Manipulators	H	Cylindres	H

Tahrik Makinası Torque Machine Machines couplées	Günlük Çalışma Müddeti (Saat) Daily Working Period (Hour) Utilisation journalière (Heure)	Makinanın Yükleme Karakteristiği Load Characteristics of Machines Caractéristique des charges		
		Hafif Yük U Uniform Load U Charge uniforme U	Orta Yük M Moderate Load M Charge modérée M	Ağır Yük H Heavy Load H Charge élevée H
<b>Elekt. Motorlu</b> / Elect. Motor / Moteurs élect. <b>Türbin</b> / Turbin / Turbine <b>Hidrolik</b> / Hydraulic / Hydraulique	0.....3	0.8	1	1.5
	3....10	1	1.25	1.75
	10...24	1.25	1.5	2
<b>Pistonlu Makinalar ( 4....6 Silindir</b> Piston Machines ( 4....6 Cylindir ) Machine à pistons ( 4.....6 Cylindres )	0.....3	1	1.25	2
	3....10	1.25	1.5	2
	10...24	1.5	1.75	2
<b>Pistonlu Makinalar ( 1....2 Silindir</b> Piston Machines ( 1....2 Cylindir ) Machine à pistons ( 1.....2 Cylindres )	0.....3	1.25	1.5	2
	3....10	1.5	1.75	2.25
	10...24	1.75	2	2.5

### Radyal Yüklerin Belirlenmesi

Meydana gelen radyal yükün hesaplanabilmesi için redüktörün çıkış veya giriş miline bağlanan iletme elemanının tipi dikkate alınmalıdır. Aşağıdaki tabloda bazı iletme elemanları faktörleri ( $f_i$ ) verilmiştir.

İletme Elemanı	İletme Elemanı Faktörü ( $f_i$ )	Açıklama
Dişli	1,15	< 17 diş
Zincir Dişli	1,40	< 13 diş
Zincir Dişli	1,25	< 20 diş
V-Kayış Kasnakları	1,75	Ön Gerilme Kuvveti
Düz Kayış Kasnakları	2,50	Ön Gerilme Kuvveti
Triger Kayış Kasnakları	1,50	Ön Gerilme Kuvveti

Mil üzerindeki radyal yük aşağıdaki formülle hesaplanır:

$$F_R = \frac{Md \cdot 2000}{d_0} \cdot f_i$$

$F_R [N]$  = Radyal Yük  
 $M_d [Nm]$  = Döndürme Momenti  
 $d_0 [mm]$  = İletme elemanının Ortalama Çapı  
 $f_i$  = İletme Elemanı Faktörü

Bu değerler gözönüne alınarak hesaplanan sonuçlar doğrultusunda, kataloğumuzda yer alan redüktörlere ait radyal yükleri görerek seçim yapabilirsiniz. Bu tablolarda verilen radyal yükler rulman ömrüne göre belirlenmiş olup  $S_f = 1$  şartına ve yükün milin ortasını yüklediği durumlar için verilmiştir.

### Determining of Overhung Loads

Type of transmission component mounting output or input shaft has to be consideration to find occurred overhung loads. Some transmission component factor ( $f_i$ ) is given at the table below.

Transmission Component	Transmission Component Factor ( $f_i$ )	Explanation
Gear	1,15	< 17 teeth
Sprockets	1,40	< 13 teeth
Sprockets	1,25	< 20 teeth
V-Belt Pulleys	1,75	Pre-tension
Flat Belt Pulleys	2,50	Pre-tension
Trigger Belt Pulleys	1,50	Pre-tension

Overhung Loads on shaft is find by at the formula below:

$$F_R = \frac{Md \cdot 2000}{d_0} \cdot f_i$$

$F_R [N]$  = Overhung Load  
 $M_d [Nm]$  = Torque  
 $d_0 [mm]$  = Mean Diameter of Transmission Component  
 $f_i$  = Transmission Component Factor

You can Choose, by seeing overhung loads belong to gearboxes in our catalog according to determined results by considering these values. The given overhung loads on the tables are determined according to working life, on  $S_f = 1$  and force which are applied to the midpoint of the shaft

### Calcul des charges radiales

Afin de determiner les charges radiales en bouts d'arbres il conviens de prendre en compte les paramètre et coefficients suivants. Le coefficient correcteur ( $f_i$ ) est a appliquer en fonction du type de transmission

Élément de transmission	Coefficient correcteur ( $f_i$ )	Remarques
Pignons	1,15	< 17 dents
Roue a chaine	1,40	< 13 dents
Roue a chaine	1,25	< 20 dents
Poulies a gorges	1,75	En fonction de la précontrainte
Poulies plates	2,50	En fonction de la précontrainte
Poulies dentées	1,50	En fonction de la précontrainte

La charge radiale en bout d'arbre se calcule en utilisant la formule suivante:

$$F_R = \frac{Md \cdot 2000}{d_0} \cdot f_i$$

$F_R [N]$  = Charge appliquée en bout d'arbre(N)  
 $M_d [Nm]$  = Couple en Nm  
 $d_0 [mm]$  = Diamètre de l'élément de transmission(mm)  
 $f_i$  = Coefficient correcteur pour charge radiale

Les résultats sont définis en fonction de la durée de vie et d'utilisation des réducteurs. Les résultats se basent sur les charges radiales appliquées au centre de l'arbre.

Radyal Yük Hesabı, Çıkış Miline etkiyen Durum için  
Calculation of Overhung Load for State Acting on Output Shaft  
Calculs des charges radiales appliquées sur l'arbre de sortie

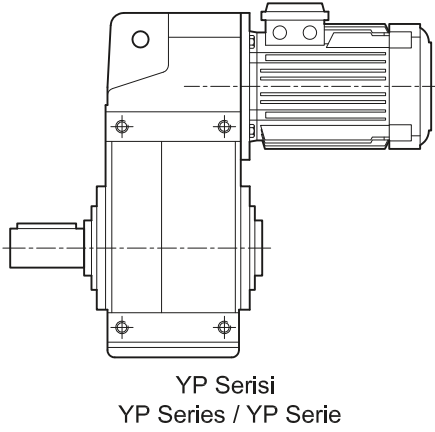

Radyal Yük Hesabı için Sabit Değerler Tablosu  
Tables of Fixed Values for Calculation of Overhung Load  
Tableau des valeurs préétablies pour le calcul des charges radiales

YP Serisi / YP Series / YP Serie				
Tip/ Type	k	c	d	l
YP 52 - 53	124.5	99.5	25	50
YP 62 - 63	146.5	116.5	30	60
YP 72 - 73	190.25	150.25	40	80
YP 82 - 83	223.65	173.65	50	100
YP 92 - 93	261.5	201	60	120
YP 102 - 103	322.5	252	70	140
YP 122 - 123	390	305	90	170
YP 142 - 143	459.75	354.75	110	210
YP 152 - 153	507	402	120	210

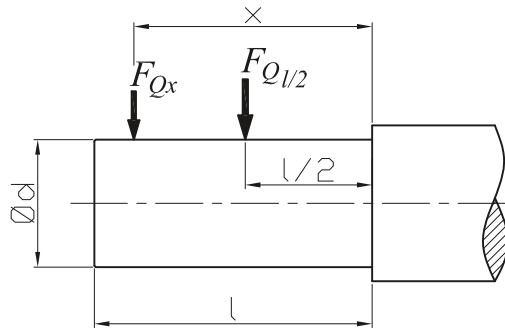

Radyal yük, milin orta noktasında değil ise  $F_{Qx} = F_{Ql/2} \cdot \frac{k}{c+x}$  formülü ile hesaplanır.

If overhung load is not applied at the midpoint of output shaft; it is calculated by  $F_{Qx} = F_{Ql/2} \cdot \frac{k}{c+x}$

Dans le cas où les charges radiales ne sont pas appliquées au centre de l'arbre d'entrée, la formule à appliquer est  $F_{Qx} = F_{Ql/2} \cdot \frac{k}{c+x}$

Radyal Yük Hesabı, Kovana etkiyen Durum için  
Calculation of Overhung Load for State Acting on Hollow Shaft  
Calcul des charges radiales appliquées en configuration arbre creux

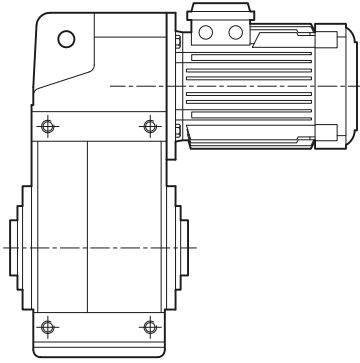

YP Serisi  
YP Series / YP Serie

Radyal Yük Hesabı için Sabit Değerler Tablosu  
Tables of Fixed Values for Calculation of Overhung Load  
Tableau des valeurs préétablies pour le calcul des charges radiales

YP Serisi / YP Series / YP Serie				
Tip/ Type	k	c	d	l
YP 52 - 53	96	96	25	-
YP 62 - 63	125.5	125.5	30	-
YP 72 - 73	146.25	146.25	40	-
YP 82 - 83	173.65	173.65	50	-
YP 92 - 93	197	197	60	-
YP 102 - 103	247	247	70	-
YP 122 - 123	303	303	90	-
YP 142 - 143	354.75	354.75	110	-
YP 153 - 153	402	402	120	-

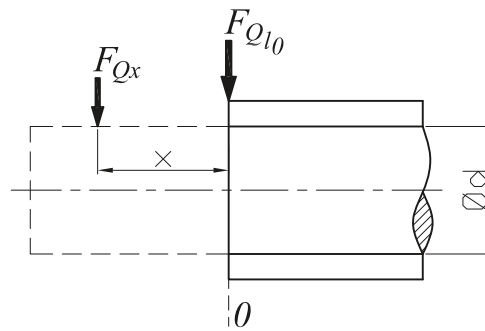

Radyal yük, kovanın 0 noktasında değil ise  $F_{Qx} = F_{Ql0} \cdot \frac{k}{c+x}$  formülü ile hesaplanır.

If overhung load is not applied at the zero point of hollow shaft; it is calculated by  $F_{Qx} = F_{Ql0} \cdot \frac{k}{c+x}$

Si les charges radiales ne sont pas appliquées au point 0 de l'arbre creux, il convient d'appliquer la formule suivante

$$F_{Qx} = F_{Ql0} \cdot \frac{k}{c+x}$$

Radyal Yük Hesabı, Giriş Miline etkiyen Durum için  
Calculation of Overhung Load for State Acting on Input Shaft  
Calcul des charges appliquées sur l'arbre d'entrée

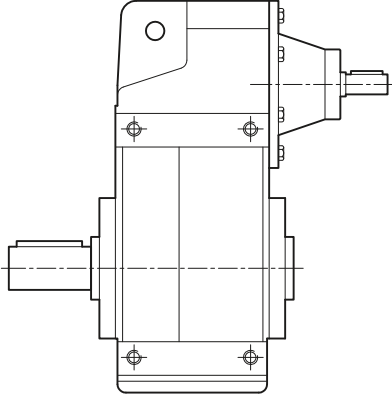

**YP Serisi**  
YP Series / YP Serie

Radyal Yük Hesabı için Sabit Değerler Tablosu  
Tables of Fixed Values for Calculation of Overhung Load  
Tableau des valeurs préétablies pour le calcul des charges radiales

YP Serisi / YP Series / YP Serie				
Tip/ Type	k	c	d	l
YP 52 - 53	83.5	63.5	19	40
YP 62 - 63	52.5	67.5	24	50
YP 72 - 73	110	77	24	50
YP 82 - 83	119	89	28	60
YP 92 - 93	123	88	34	70
YP 102 - 103	159.5	109.5	48	100
YP 122 - 123	187,5	132,5	55	110
YP 142 - 143	233	178	55	110
YP 152 - 153	341,5	201,5	70	140

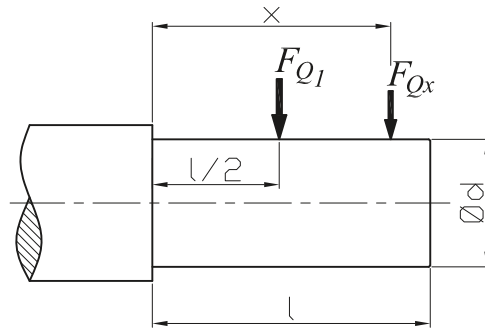

Radyal yük, milin orta noktasında değil ise  $F_{Qx} = F_{Q1} \cdot \frac{k}{c+x}$  formülü ile hesaplanır.

If overhung load is not applied at the midpoint of input shaft; it is calculated by  $F_{Qx} = F_{Q1/2} \cdot \frac{k}{c+x}$

Dans le cas où les charges radiales ne sont appliquées au centre de l'arbre d'entrée, la formule à appliquer est

$$F_{Qx} = F_{Q1/2} \cdot \frac{k}{c+x}$$

**1500 d/d Motorlar / Motors / Moteurs**

Kod	Güç (KW)	Hız (d/d)	Anma Akımı	Moment (Nm)	Verim		IE Sınıfı	Çalışma Sınıfı
					100%	75%		
Code	Power (KW)	Speed (r.p.m.)	Rated Current	Torque (Nm)	Efficiency		IE Class	Duty Type
					100%	75%		
Code	Puissance (kW)	Vitesse (r.p.m.)	Ampère	Couple (Nm)	Efficience		Classe IE	Classe d'utilisation
					100%	75%		
63M4a	0,12	1365	0,41	0,84	57,1	57,1	IE1	S1
63M4b	0,18	1340	0,60	1,28	59,7	59,7	IE1	S1
C63M4	0,25	1350	0,95	1,77	60,7	60,7	IE1	S1
71M4a	0,25	1380	0,81	1,73	61,9	61,8	IE1	S1
71M4b	0,37	1390	1,15	2,54	68,1	68,1	IE1	S1
C71M4	0,55	1385	1,50	3,75	68,6	68,6	IE1	S1
80M4a	0,55	1365	1,60	3,85	69,1	69,0	IE1	S1
80M4b	0,75	1410	2,10	5,08	79,6	79,6	IE2	S1
90S4	1,1	1420	2,60	7,39	82,0	82,0	IE2	S1
90L4	1,5	1430	3,50	10,02	83,0	83,0	IE2	S1
C90L4	2,2	1435	5,00	14,60	84,4	84,5	IE2	S1
100L4a	2,2	1435	5,00	14,60	84,5	84,6	IE2	S1
100L4b	3	1435	6,60	20,00	85,5	85,7	IE2	S1
C100L4	4	1455	8,20	26,30	86,5	86,6	IE2	S1
112M4	4	1455	8,20	26,30	86,7	86,8	IE2	S1
132S4	5,5	1465	11,20	35,90	87,9	88,8	IE2	S1
132M4	7,5	1465	15,40	48,90	89,0	89,1	IE2	S1
C132M4	11	1465	21,00	71,70	89,9	90,0	IE2	S1
160M4	11	1465	21,00	71,70	90,0	90,1	IE2	S1
160L4	15	1465	29,80	97,80	90,6	90,7	IE2	S1
180M4	18,5	1470	34,50	120,00	91,3	91,4	IE2	S1
180L4	22	1470	42,50	143,00	91,7	91,4	IE2	S1
200L4	30	1470	55,00	195,00	92,5	92,6	IE2	S1
225S4	37	1470	67,00	240,00	92,7	92,7	IE2	S1
225M4	45	1470	80,00	292,00	93,3	93,3	IE2	S1
250M4	55	1475	96,00	356,00	93,7	93,8	IE2	S1
280S4	75	1480	133,00	484,00	94,0	94,1	IE2	S1
280M4	90	1480	158,00	581,00	94,3	94,5	IE2	S1
315S4	110	1485	195,00	707,00	94,5	94,5	IE2	S1
315M4	132	1485	230,00	849,00	94,7	94,5	IE2	S1
315M4	160	1485	280,00	1029,00	94,9	94,9	IE2	S1
315L4	185	1485	323,00	1190,00	95,1	95,1	IE2	S1
315L4	200	1485	350,00	1286,00	95,1	95,1	IE2	S1

**1000 d/d Motorlar / Motors / Moteurs**

Kod	Güç (KW)	Hız (d/d)	Anma Akımı	Moment (Nm)	Verim		IE Sınıfı	Çalışma Sınıfı
					100%	75%		
Code	Power (KW)	Speed (r.p.m.)	Rated Current	Torque (Nm)	Efficiency		IE Class	Duty Type
					100%	75%		
Code	Puissance (kW)	Vitesse (r.p.m)	Ampère	Couple (Nm)	Efficience		Classe IE	Classe d'utilisation
					100%	75%		
71M6a	0,18	915	0,61	1,88	63,0	62,9	IE1	S1
71M6b	0,25	915	0,83	2,61	63,8	63,7	IE1	S1
80M6a	0,37	910	1,10	3,88	72,9	72,8	IE1	S1
80M6b	0,55	890	1,50	5,90	70,4	70,3	IE1	S1
90S6	0,75	920	2,00	7,79	75,9	75,9	IE2	S1
90L6	1,1	930	2,90	11,30	78,1	78,1	IE2	S1
100L6	1,5	945	3,60	15,20	79,8	79,7	IE2	S1
112M6	2,2	950	5,40	22,00	81,8	81,7	IE2	S1
132S6	3	960	6,90	29,80	83,3	83,2	IE2	S1
132M6a	4	960	9,00	39,80	84,6	84,5	IE2	S1
132M6b	5,5	960	12,30	54,70	86,0	86,0	IE2	S1
160M6	7,5	960	15,00	74,60	87,2	87,2	IE2	S1
160L6	11	965	22,00	108,90	88,7	88,7	IE2	S1
180L6	15	965	29,00	148,00	89,7	89,7	IE2	S1
200L6a	18,5	975	38,00	182,00	90,4	90,4	IE2	S1
200L6b	22	970	43,00	216,50	91,1	91,1	IE2	S1
225M6	30	980	58,00	292,00	91,7	91,7	IE2	S1
250M6	37	985	69,00	359,00	92,2	92,2	IE2	S1
250S6	45	985	92,00	436,00	92,7	92,7	IE2	S1

\* Motor teknik değerleri GAMAK marka motorlar içindir, kullanılan diğer markalar için değişiklik gösterebilir.



## Frenler

### 1) Pervanesiz frenler

Elektrik motorunun arkasındaki soğutma kapağı takılmayarak bunların yerine monte edilen frenlerdir. Kısa süreli çalışan motorlarda bu tip frenler kullanılır.

### 2) Pervaneli frenler

Elektrik motorunun motor mili ve fan kapağı uzatılarak monte edilen frenlerdir. Devamlı çalışan motorlarda bu tip frenler kullanılır.

### 3) Mikro anahtarlı frenler

Elektrik motorlarının demeraj akımının yüksek olması ve freni açmada gecikmesi dolayısıyla istenmeyen durumlar meydana gelir. Bunları önlemek için, frenin üzerine konulan bir mikro anahtar vasıtasıyla freni açtıktan hemen sonra motorun çalışması sağlanır. Bu tip frenler özellikle büyük güçteki redüktörlerin elektrik motorları için uygundur.

### Redüktörlerin ani veya gecikmeli frenlenmesi

Gecikmeli veya ani frenlenen redüktörler birçok sanayi makinalarında kullanılmaktadır. Bu sebepten frenler hem ani hem de gecikmeli fren yapacak şekilde dizayn edilmişlerdir. Frenlerin elektrik bağlantısında yapılacak bir değişiklikle ani veya gecikmeli frenleme sağlanır. Her frenli redüktör ile birlikte elektrik bağlantı şeması verilmektedir.

*Frenli redüktörleri teslim aldığınızda fren bağlantısının gecikmeli olarak yapıldığını unutmayınız.*

## Brakes

### 1) Brakes without cooling fan

Brake which is mounted on fan side of electric motor by cancelling cooling fan and fan cover of motor. This type of brake is used for a short period running motors.

### 2) Brakes with cooling fan

Brake which is mounted on fan side of electric motor by extending motor shaft and fan cover to use fan. This type of brake is necessary for continuously running motors

### 3) Brakes with micro switch

Because of high starting current of motors delayed disengagement of magnetic brakes undesirable conditions occur. To prevent this situation, starting of motor is provided after disengagement of brake by means of brake by means of a micro switch installed on the brake. This type of brake is especially suitable for high power geared motors.

### Non-delayed or delayed braking of geared motors

Delayed or non-delayed geared motors are used in many industrial machines. Therefore, brakes are designed to operate in both delayed and non-delayed conditions. This is supplied with each brake mounted geared motor.

*Please do not forget that the brakes are connected for delayed operations standard.*

## Freins

### 1) Freins sans hélices de refroidissements

Freins montés directement à l'emplacement de l'hélice de refroidissement. Dans cette configuration l'hélice et le couvercle extérieur sont retirés. Ce type de configuration est conseillé pour les applications et moteurs avec une durée de fonctionnement réduite.

### 2) Freins avec hélice de refroidissement

Le frein est monté directement à l'arrière de l'emplacement de l'hélice de refroidissement. Ce type de configuration nécessite une prolongation de l'arbre d'entraînement du moteur. Ce type de configuration est conseillé pour les applications nécessitant un usage continu du frein.

### 3) Frein à ouverture manuelle

La forte charge appliquée par le moteur sur certains freins entraîne une prolongation de la période de blocage. Afin d'éviter un arrêt prolongé certains freins sont équipés d'un clé d'ouverture manuelle, cette option permet un redémarrage immédiat du moteur. Ce type de freins est particulièrement adapté aux moteurs à forte puissance.

### Freins avec ou sans retardement d'arrêt.

Les motoréducteurs équipés de freins à retardement d'arrêt sont utilisés dans notre nombreuses applications et secteurs. Les freins sont conçus pour opérés avec ou sans l'option de retardement. Cette option est disponible pour l'ensemble de notre gamme de motoréducteurs. A noter que le freins dois être correctement connecté pour permettre un fonctionnement optimale de cette option.

### Fren alıştırma voltajları

Frenler 24V-DC veya 220V-AC ile çalışacak şekilde imal edilir. 220 voltluk frenlerin bağlantıları motor klemens kutusunda yapılmaktadır. 24V ile çalışan frenlerin bağlantısı için ayrıca 220/30V trafo ile doğrultucu gerekmektedir. İstenildiğinde bunlar firmamızca temin edilmektedir.

Frenli redüktörlerin elektrik motorlarına toprak hattı bağlantısı muhakkak yapılmalıdır.

### Fren siparişlerinde belirtilmesi gereken hususlar

- 1) Fren momenti
- 2) Fren tipi
- 3) Fren voltajı

24V ile çalışan fren siparişlerinde trafolu doğrultucu istenip istenmediğini lütfen belirtiniz.

### Fren bağlantı şemaları

### Operating voltage of brakes

Brakes are manufactured to operate at 24V-DC or 220V-AC. 220V brakes are connected to the motor terminal box directly, but 220/30V transformer with rectifier unit needed for 24V operating brakes. This unit will be supplied if required.

Geared brake motors must be earthed.

### Required ordering data for brakes

- 1) Brake torque
- 2) Brake type
- 3) Brake operating voltage.

Please inform as if you need 220/30V transformer with rectifier unit for 24V operating brakes

### Brake connection types

### Voltage et caractéristique des freins

Les freins sont adaptés à un voltage de 24V-DC ou 220V-AC. Les freins fonctionnant sous 220V sont directement connectés à la boîte de Klemens, Les freins fonctionnant sous 24V doivent impérativement être couplés à un transformateur, cette unité est disponible en option.

### Données Nécessaire à la Commande d'un Frein.

- 1) Couple des freins
- 2) Type de freins
- 3) Type de voltage

Veillez à nous informer si une unité de transformation 220/30V est nécessaire au branchement de votre frein ( 24 V )

### Type de connexion des freins

#### Gecikmeli Frenleme (24V)

Delayed Running Brake (24V)  
Frein à retardement (24 V)

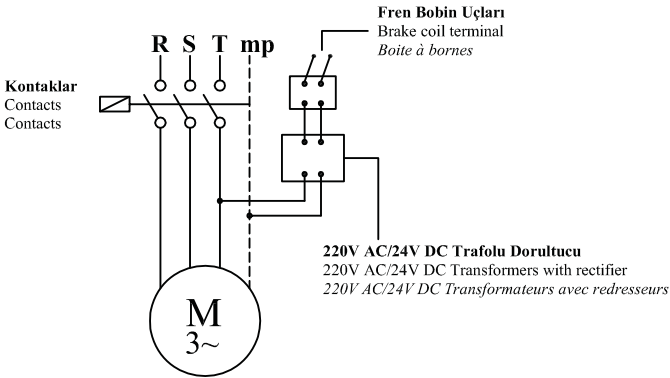

#### Ani Frenleme (24V)

Sudden Running Brake (24V)  
Frein à arrêt immédiat (24 V)

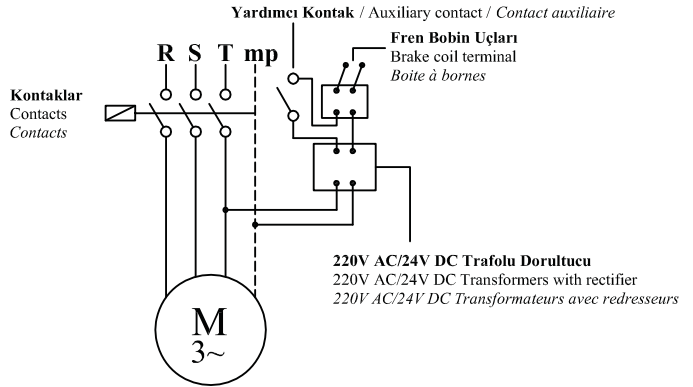

#### Gecikmeli Frenleme (220V)

Delayed Running Brake (220V)  
Frein à retardement (220 V)

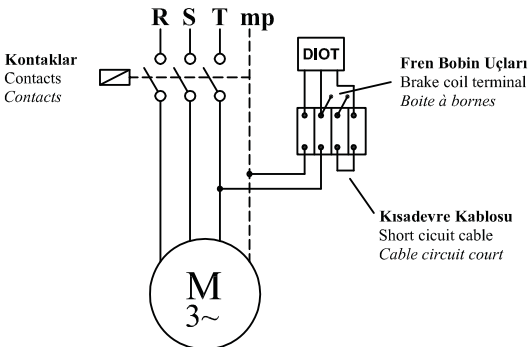

#### Ani Frenleme (220V)

Sudden Running Brake (220V)  
Frein à arrêt immédiat (220 V)

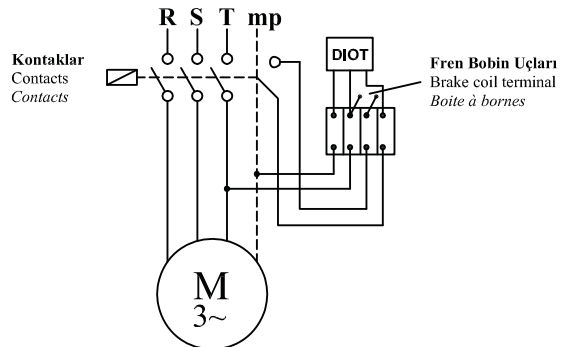

Tablo 1 / Table 1 / Tableau 1

Motor büyüklüğü Motor size Dimensions du moteur	n1 d/d / r.p.m / r.p.m			
	750	1000	1500	3000
	Güç / Power / Puissance [kW]			
63			0,12 - 0,18	0,18 - 0,25
71	0,09 - 0,12	0,18 - 0,28	0,25 - 0,37	0,37 - 0,55
80	0,18 - 0,25	0,37 - 0,55	0,55 - 0,75	0,75 - 1,1
90 S	0,37	0,75	1,1	1,5
90 L	0,55	1,1	1,5	2,2
100	0,75 - 1,1	1,5	2,2 - 3	3
112	1,5	2,2	4	4
132 S	2,2	3	5,5	5,5 - 7,5
132 M	3	4 - 5,5	7,5	11
160 M	4-5,5	7,5	11	15
160 L	7,5	11	15	18,5
180 M			18,5	22
180 L	11	15	22	
200	15	18,5 - 22	30	30 - 37
225 S	18,5		37	
225 M	22	30	45	45
250	30	37	55	55
280 S	37	45	75	75
280 M	45	55	90	90

Tablo 2 / Table 2 / Tableau 2

Motor büyüklüğü Motor size Dimensions du moteur	Fren momenti [kgm] Braking torque [kgm] Puissance de freinage [kgm]																			
	Hafif frenleme Light braking Freins legers										Kuvvetli frenleme Strong braking Freins lourds									
	0,5	1	2,5	4	5	10	20	30	50	80	0,5	1	2,5	4	5	10	20	30	50	80
63																				
71																				
80																				
90 S																				
90 L																				
100																				
112																				
132 S																				
132 M																				
160 M																				
160 L																				
180 M																				
180 L																				
200																				
225 S																				
225 M																				
250																				
280 S																				
280 M																				

## Lastik takozları

YP tip redüktörler için özel olarak tasarlanmış montaj lastikleri ile, redüktörlerin kolayca montajını gerçekleştirebilirsiniz. Moment kolu prensibi mantığında çalışacak bir sistemde, redüktör ani kalkışlara ve mil salgılarına karşı korunmuş olacaktır. Sistemsel kasma ve gerilmeler de minimize edilmiş olacaktır.



## Torque arm

The YP Series gearbox are configured with special mounting options. The rubber rings are working as torque arms for the gearbox, the special rubber material is also designed to resist shocks and absorb the vibration of the housing and output shaft.

## Bras d'attraction

Les réducteurs de la série YP sont équipés d'anneaux en caoutchouc pour faciliter le montage avec une configuration en arbre creux. Les composants de ces anneaux sont spécialement étudiés pour résister aux chocs tout en absorbant un maximum les vibrations transmises par l'application en marche.

Ayak montajlı redüktörlerde montaj pozisyonu "P" ile gösterilir

Foot mounted gearboxes position are defined as "P"

Les positions de montages des réducteurs à pattes sont définis par "P"

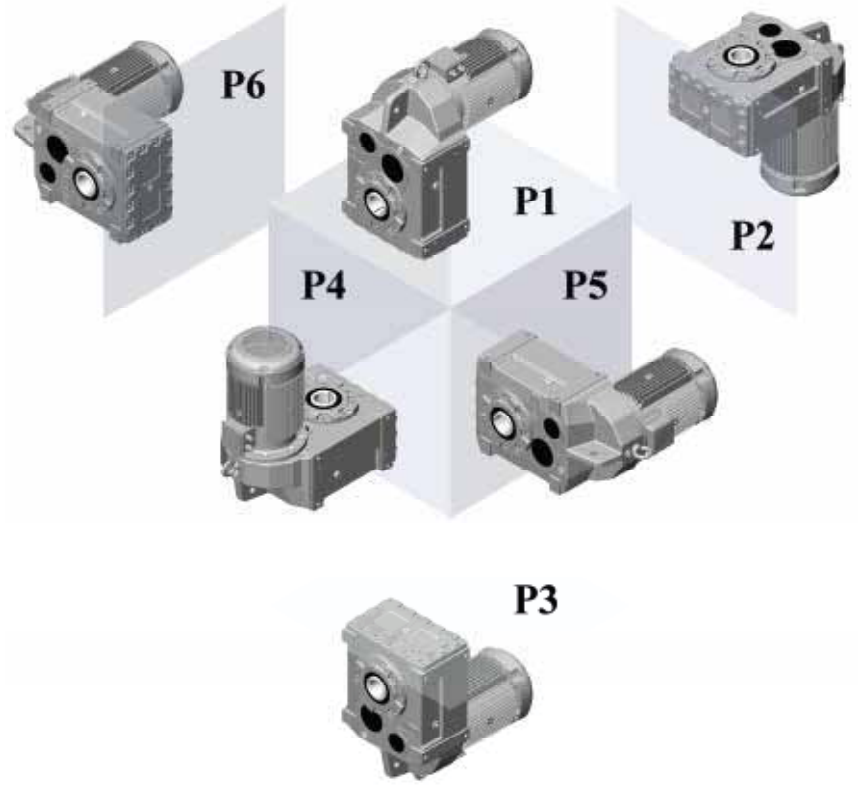

Flanş montajlı redüktörlerde montaj pozisyonu "V" ile gösterilir

Flange mounted gearboxes position are defined as "V"

Les positions de montages des réducteurs à brides sont définis par "V"

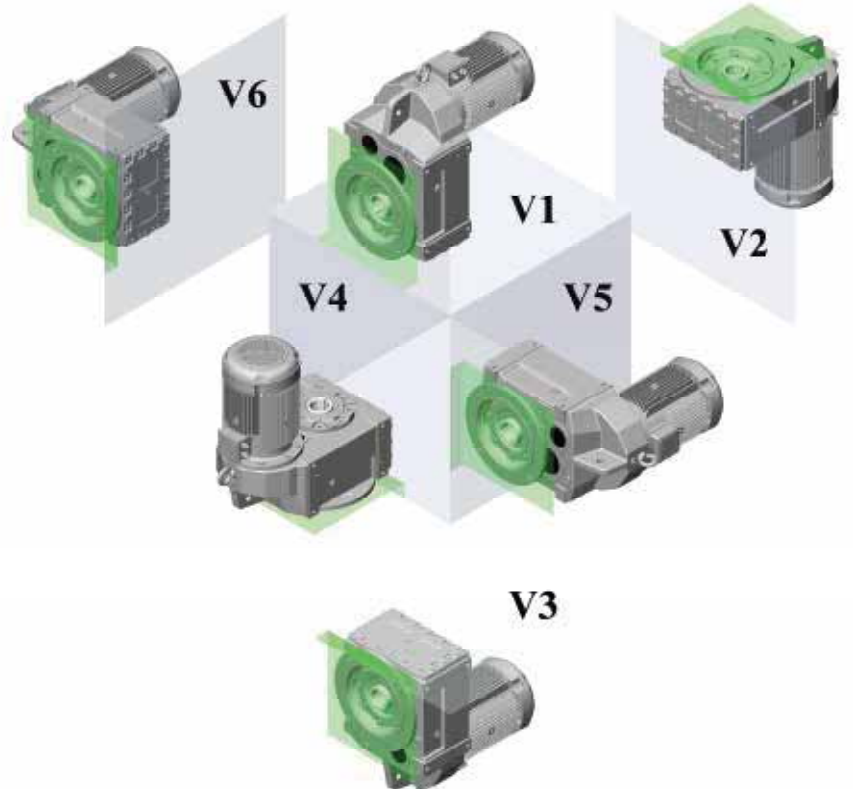

Standart klemens pozisyonu "KP1" dir, aksi belirtilmediği sürece standart pozisyonunda yapılır.

The standard mounting position is "KP1", if the mounting is not during the order, the mounting position is always "KP1"

La position de montage standard est "KP1", si aucune position de montage n'est précisée lors de la prise de commande, la position "KP1" sera attribuée par défaut

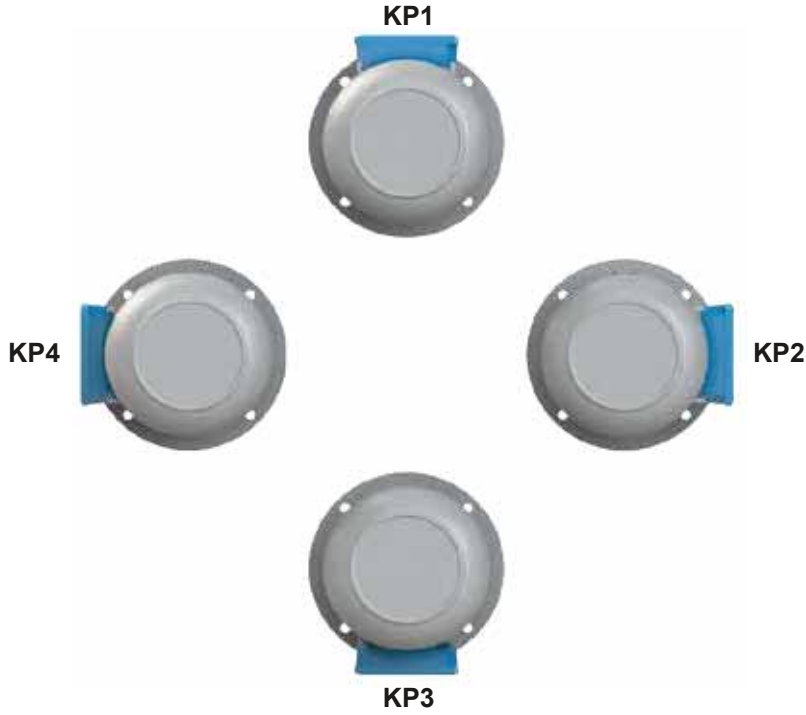
**Rakor yönleri**

Cable entry / Entrée des câbles

Standart rakor yönü "A" dır, belirtilmediği sürece standart yönde yapılır.

The standard position of the cable entry "A", if the position is not during the order, the mounting position is always "A"

La position standard de l'entrée des cables est "A", si aucune position de montage n'est précisée lors de la prise de commande, la position "A" sera attribuée par défaut.



Yağ Cinsi Lubrifiant Art des Lubrifiant	ISO Viskozite sinifi Viscosity class Catégorie de viscosite	DIN 51517-3	Kullanım sicaklığı Usage temperature Gebrauchs temperatur d'usage C°	Firma Firm Marque						
				Mobil	ARAL	bp	Shell	Castrol	KLÜBER LUBRICATION	BELGiN
Mineral Yağ Mineral Oil Huile Minéral	ISO VG 320	CLP	-10.....+90	Mobilgear 600XP320	Degol BG 320	Energol GR-XP 320	OmalaS2 GX 320	Alpha SP 320	Klüberoil GEM 1 N 320	Recompound FL 320
	ISO VG 220	CLP	-10.....+90	Mobilgear 600 XP 220	Degol BG 220	Energol GR-XP 220	OmalaS2 GX 220	Alpha SP 220	Klüberoil GEM 1 N 220	Recompound FL 220
	ISO VG 150	CLP	-10.....+90	Mobilgear 600 XP 150	Degol BG 150	Energol GR-XP 150	OmalaS2 GX 150	Alpha SP 150	Klüberoil GEM 1 N 150	Recompound FL 150
	ISO VG 100	CLP	-15.....+90	Mobilgear 600 XP 100	-	-	OmalaS2 GX 100	Alpha SP 100	Klüberoil GEM 1 N 100	Recompound FL 100
Sentetik Yağ Synthetic Oil Huile Synthétique	ISO VG 320	CLP HC	-30.....+110	Mobil SHC Gear 320	Degol GS 320	Energol SG-XP320	OmalaS4 GX V 320	Optigear Synthetic PD 320 ES	Klübersynth GEM 4N 320	Recompound Syn 320
	ISO VG 220	CLP HC	-35.....+110	Mobil SHC Gear 220	Degol GS 220	Energol SG-XP220	OmalaS4 GX V 220	Optigear Synthetic PD 220 ES	Klübersynth GEM 4N 220	Recompound Syn 220
	ISO VG 150	CLP HC	-40.....+110	Mobil SHC Gear 150	Degol GS 150	Energol SG-XP150	OmalaS4 GX V 150	Optigear Synthetic PD 150 ES	Klübersynth GEM 4N 150	Recompound Syn 150
	ISO VG 100	CLP HC	-45.....+110	Mobil SHC 627	-	-	-	Optigear Synthetic PD 100 ES	Klübersynth GEM 4N 100	Recompound Syn 100

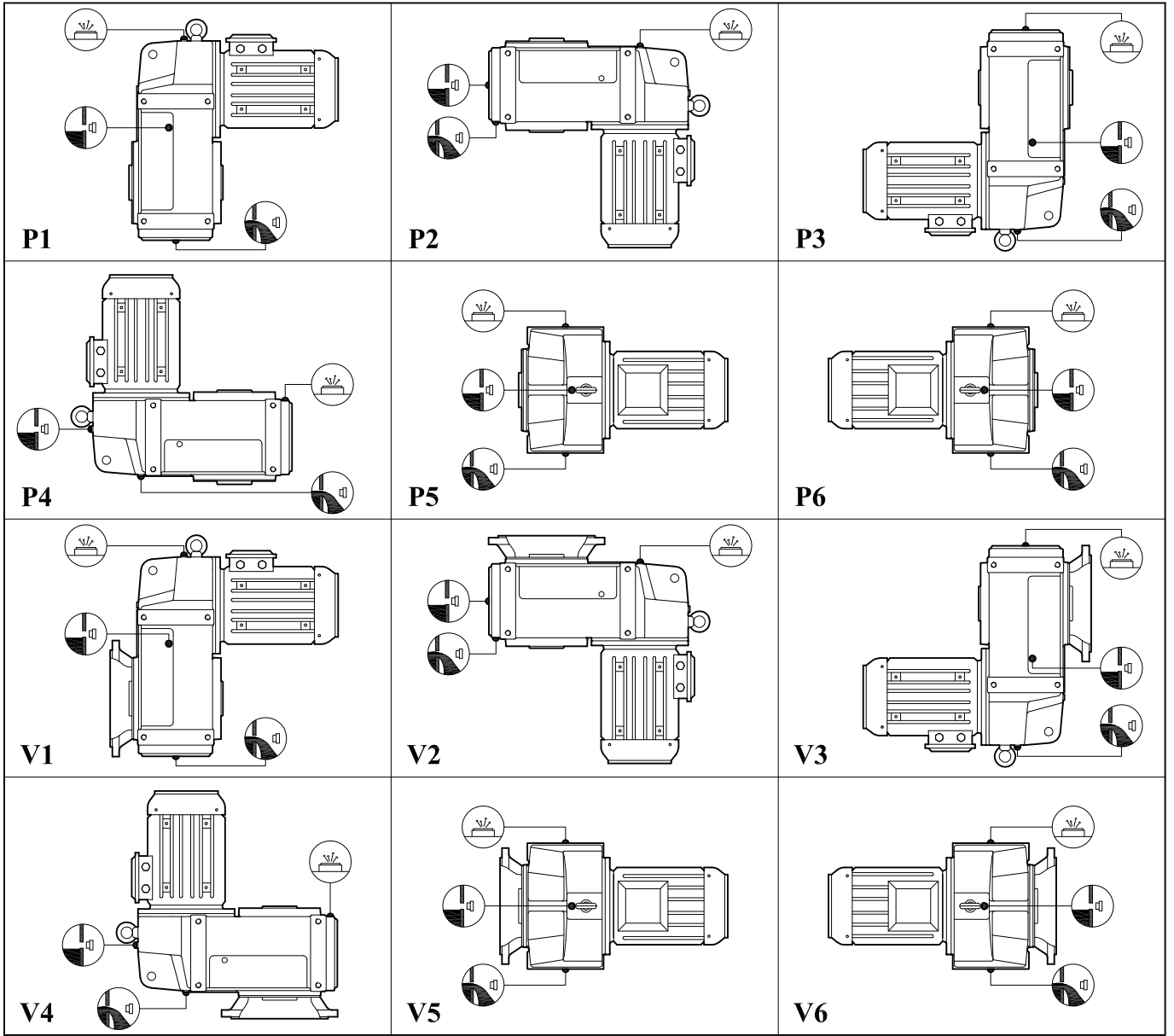

**Semboller :**  
Seymbols :  
Seymboles :



**Yağ Doldurma ve Havalandırma**  
Oil Filling and Vent Plug  
Valve d'aération



**Yağ Seviye Tespit**  
Oil Level  
Niveau d'huile



**Yağ Boşaltma**  
Oil Drain Plug  
Bouchon de drainage

TİP Type Type	Bağlantı Pozisyonları ve Yağ Miktarları ( litre ) Oil Quantities for Mounting Positions ( liter ) Quantités d'huiles en fonction da la position de montage ( lites )											
	P1	V1	P2	V2	P4	V4	P3	V3	P5	V5	P6	V6
YP... 52 / 53	1,1 / 0,9			1,4 / 1,2			0,9 / 0,7				1,1 / 0,9	
YP... 62 / 63	1,6 / 1,4			1,9 / 1,7			1,2 / 1				1,6 / 1,4	
YP... 72 / 73	3 / 2,7			4,1 / 3,8			3,2 / 9				4,1 / 3,8	
YP... 82 / 83	6,3 / 5,9			7,7 / 7,3			4,7 / 4,3				6,4 / 6	
YP... 92 / 93	13 / 11			16 / 13			11 / 8				14 / 11	
YP... 102 / 103	20 / 17			24 / 21			20 / 17				18 / 15	
YP... 122 / 123	27 / 24			35 / 32			24 / 11				30 / 27	
YP... 142 / 143	44 / 40			53 / 49			41 / 33				47 / 45	
YP... 152 / 153	76 / 70			86 / 80			61 / 55				80 / 75	



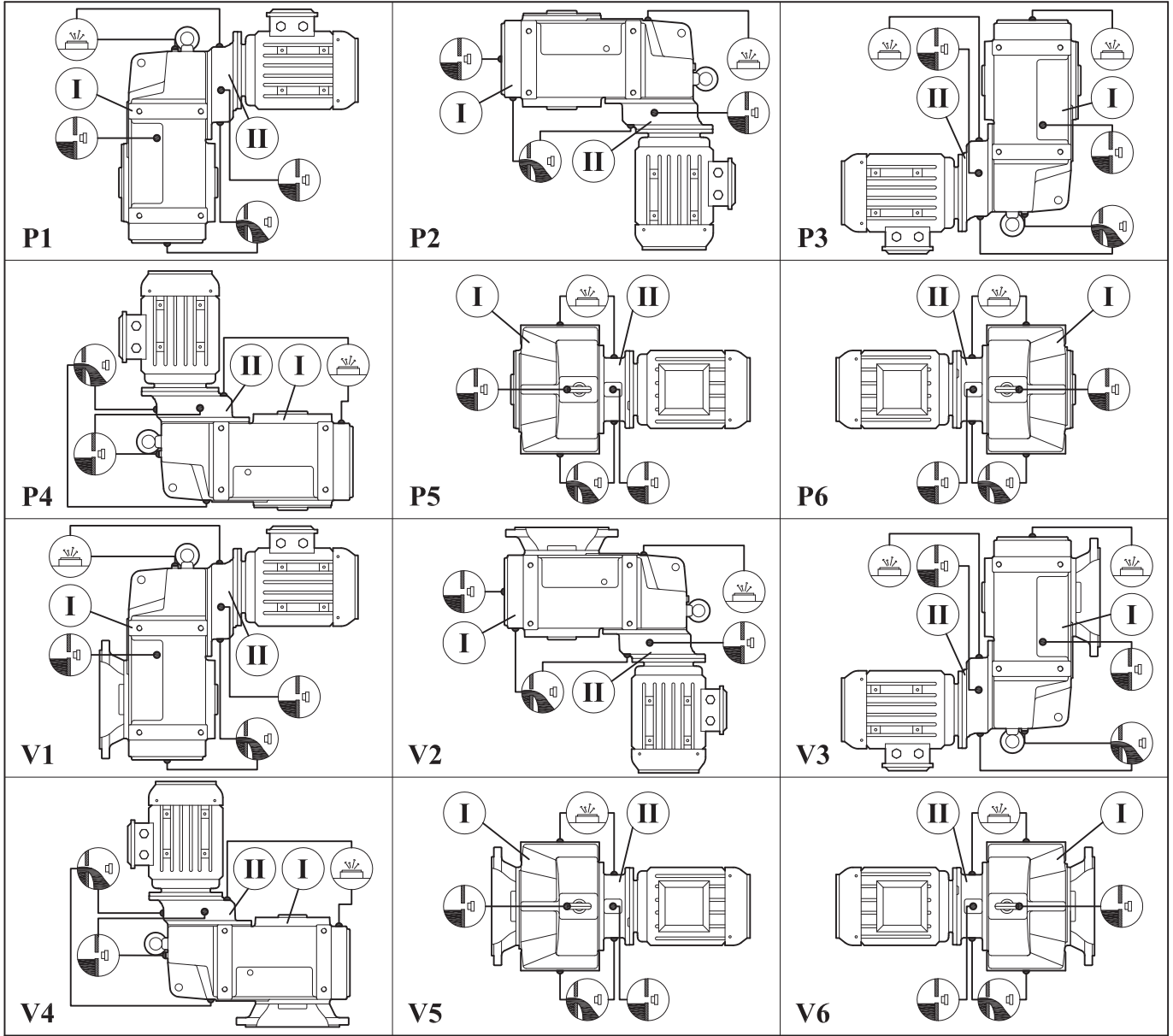

Semboller :  
Seymbols :  
Seymboles :



**Yağ Doldurma ve Havalandırma**  
Oil Filling and Vent Plug  
Valve d'aération



**Yağ Seviye Tespit**  
Oil Level  
Niveau d'huile



**Yağ Boşaltma**  
Oil Drain Plug  
Bouchon de drainage

TİP Type Type	Bağlantı Pozisyonları ve Yağ Miktarları ( litre ) Oil Quantities for Mounting Positions ( liter ) Quantités d'huiles en fonction de la position de montage ( litres )											
	P1	V1	P2	V2	P3	V3	P4	V4	P5	V5	P6	V6
	I / II		I / II		I / II		I / II		I / II			
YP.... 74	2,7 / 0,1		3,8 / 0,3		2,9 / 0,25		3,8 / 0,2		3,8 / 0,2			
YP.... 84	5,9 / 0,2		7,3 / 0,35		4,3 / 0,4		7,3 / 0,35		6 / 0,35			
YP.... 94	11 / 0,3		13 / 0,75		8 / 0,75		13 / 0,5		11 / 0,5			
YP.... 104	17 / 0,6		21 / 1,2		17 / 1,3		21 / 1,1		15 / 1			
YP.... 124	24 / 0,7		32 / 1,35		21 / 1,8		32 / 1,5		27 / 1,2			
YP.... 144	40 / 1,85		49 / 4		33 / 4,5		49 / 4		45 / 2,75			
YP.... 154	70 / 4,35		80 / 6,5		55 / 7		80 / 6,5		75 / 5,25			

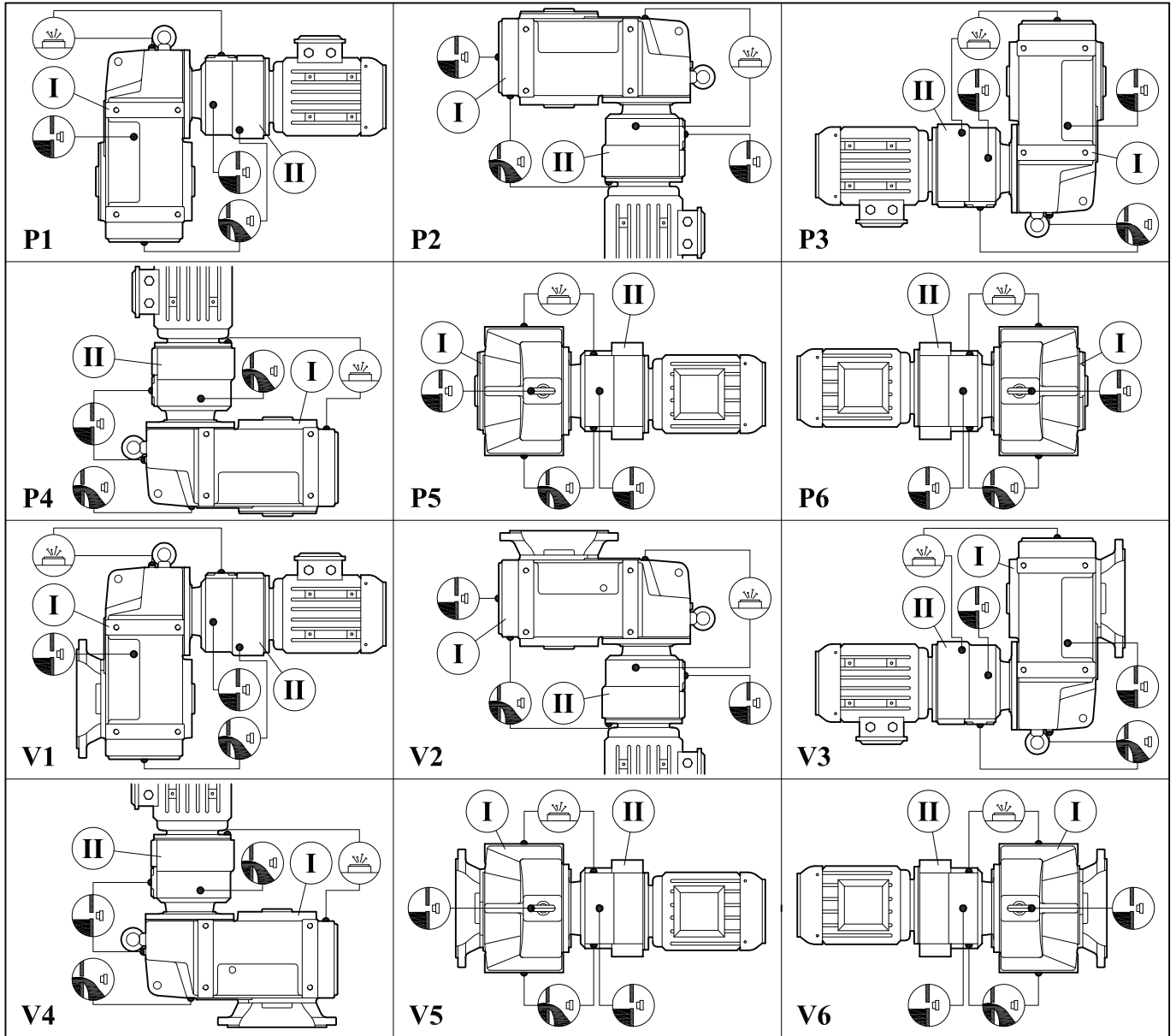

Semboller :  
Seymbols :  
Seymboles :



**Yağ Doldurma ve Havalandırma**  
Oil Filling and Vent Plug  
Valve d'aération



**Yağ Seviye Tespit**  
Oil Level  
Niveau d'huile



**Yağ Boşaltma**  
Oil Drain Plug  
Bouchon de drainage

TİP Type Type	Bağlantı Pozisyonları ve Yağ Miktarları ( litre ) Oil Quantities for Mounting Positions ( liter ) Quantités d'huiles en fonction da la position de montage ( litres )											
	P1	V1	P2	V2	P4	V4	P3	V3	P5	V5	P6	V6
	I / II		I / II		I / II		I / II		I / II		I / II	
YP.... 52 İR 42	1,1	0,4		1,4	0,7		0,9	0,5		1,1	0,5	
YP.... 52 İR 43	1,1	0,35		1,4	0,65		0,9	0,45		1,1	0,45	
YP.... 53 İR 42	0,9	0,4		1,2	0,7		0,7	0,5		0,9	0,5	
YP.... 53 İR 43	0,9	0,35		1,2	0,65		0,7	0,45		0,9	0,45	
YP.... 62 İR 42	1,6	0,4		1,9	0,7		1,2	0,5		1,6	0,5	
YP.... 62 İR 43	1,6	0,35		1,9	0,65		1,2	0,45		1,6	0,45	
YP.... 63 İR 42	1,4	0,4		1,7	0,7		1	0,5		1,4	0,5	
YP.... 63 İR 43	1,4	0,35		1,7	0,65		1	0,45		1,4	0,45	
YP.... 72 İR 52	3	0,8		4,1	1,2		3,2	0,8		4,1	0,8	
YP.... 72 İR 53	3	0,75		4,1	1,15		3,2	0,75		4,1	0,75	

TİP Type Type	Bağlantı Pozisyonları ve Yağ Miktarları ( litre )											
	Oil Quantities for Mounting Positions ( liter )											
	Quantités d'huiles en fonction de la position de montage ( litres )											
	P1	V1	P2	V2	P4	V4	P3	V3	P5	V5	P6	V6
I / II		I / II				I / II		I / II				
YP.... 73 İR 52	2,7 / 0,8		3,8 / 1,2				9 / 0,8		3,8 / 0,8			
YP.... 73 İR 53	2,7 / 0,75		3,8 / 1,15				9 / 0,75		3,8 / 0,75			
YP.... 82 İR 52	6,3 / 0,8		7,7 / 1,2				4,7 / 0,8		6,4 / 0,8			
YP.... 82 İR 53	6,3 / 0,75		7,7 / 1,15				4,7 / 0,75		6,4 / 0,75			
YP.... 83 İR 52	5,9 / 0,8		7,3 / 1,2				4,3 / 0,8		6 / 0,8			
YP.... 83 İR 53	5,9 / 0,75		7,3 / 1,15				4,3 / 0,75		6 / 0,75			
YP.... 92 İR 62	13 / 1,25		16 / 1,8				11 / 1,25		14 / 1,25			
YP.... 92 İR 63	13 / 1,1		16 / 1,65				11 / 1,1		14 / 1,1			
YP.... 93 İR 62	11 / 1,25		13 / 1,8				8 / 1,25		11 / 1,25			
YP.... 93 İR 63	11 / 1,1		13 / 1,65				8 / 1,1		11 / 1,1			
YP.... 102 İR 62	20 / 1,25		24 / 1,8				20 / 1,25		18 / 1,25			
YP.... 102 İR 63	20 / 1,1		24 / 1,65				20 / 1,1		18 / 1,1			
YP.... 103 İR 62	17 / 1,25		21 / 1,8				17 / 1,25		15 / 1,25			
YP.... 103 İR 63	17 / 1,1		21 / 1,65				17 / 1,1		15 / 1,1			
YP.... 122 İR 72	27 / 2,5		35 / 3				24 / 2,5		30 / 2,5			
YP.... 122 İR 73	27 / 2,3		35 / 2,8				24 / 2,3		30 / 2,3			
YP.... 123 İR 72	24 / 2,5		32 / 3				11 / 2,5		27 / 2,5			
YP.... 123 İR 73	24 / 2,3		32 / 2,8				11 / 2,3		27 / 2,3			
YP.... 142 İR 72	44 / 2,5		53 / 3				41 / 2,5		47 / 2,5			
YP.... 142 İR 73	44 / 2,3		53 / 2,8				41 / 2,3		47 / 2,3			
YP.... 143 İR 72	40 / 2,5		49 / 3				33 / 2,5		45 / 2,5			
YP.... 143 İR 73	40 / 2,3		49 / 2,8				33 / 2,3		45 / 2,3			
YP.... 142 İR 82	40 / 5,5		49 / 7,5				33 / 5,5		45 / 5,5			
YP.... 152 İR 82	76 / 5,5		86 / 7,5				61 / 5,5		80 / 5,5			
YP.... 152 İR 83	76 / 5		86 / 7				61 / 5		80 / 5			
YP.... 153 İR 82	70 / 5,5		80 / 7,5				55 / 5,5		75 / 5,5			
YP.... 153 İR 83	70 / 5		80 / 7				55 / 5		75 / 5			
YP.... 153 İR 92	70 / 9		80 / 11				55 / 9		75 / 9			

## Redüktörlerin Kontrol ve Bakımları

- Redüktörlerin yağ seviyesi ve miktarını kontrol ediniz. Yağın cinsini İ.MAK kataloğunda yer alan yağ çizelgelerini kullanarak seçiniz.
- Havalandırma tapasının faal olup olmadığına bakınız. Hava tahliye deliği çalışmaz ise redüktör gövdesinin içinde biriken hava, basınç oluşturarak keçelerden yağ sızmasına sebep olur. Böylece yağ azalarak çevre kirliliğine yol açar ve redüktörün verimli çalışmasını engellemiş olur.
- Redüktör bağlantı cıvatalarının gevşeyip gevşemediğini kontrol ediniz, gevşeyen cıvatalar var ise sıkılaşma suretiyle tedbir alınız. Redüktör montajında meydana gelen eksen kaçıklığında zararlı sarsıntılara dikkat ediniz.
- Redüktörün ilk çalıştırmadan 500 saat sonra, sonraki her 6000 saatte periyodik olarak yağınızı değiştiriniz.
- Özel hususlar ve çalışma şartları hakkında mutlaka firmamıza danışınız.

## Control and maintenance gearboxes

- Check the oil levels and quantity of your gearboxes. Choose the type and quantity of oil from the İ.MAK catalogue.
- Check if the ventilation stopper is active or not. If the air evacuation hole does not work properly, the accumulated air in the gearbox trunk might causes pressure and gas leakage from the mats.
- Before starting your geared motors, proceed to the checking of connection bolts and screw. Check if they have loosened or not during transport or installation. Take measures by firming loosened bolts. A wrong connexion might create vibration to the axis and conduct to damage of the geared motor.
- Change the oil after 500 hours of initial operation and periodically every 6000 hours of operating the geared motor.
- If you are facing any technical issue, please consult the user guide delivered with the geared motor. In case of special issue or emergency please directly contact your reseller or the closest I-MAK technical center.

## Contrôle et maintenance des réducteurs

- Vérifiez le niveau et la quantité d'huile de façons régulière. Consultez le catalogue I-MAK pour obtenir les niveaux d'huiles requis en fonction du modèle et de la position du réducteur.
- Vérifiez le fonctionnement de la valve d'aération. L'absence d'évacuation de l'air peut provoquer une augmentation de la pression dans le réducteur pouvant conduire à des fuites d'huiles.
- Contrôler les vis et boulons reliant le moteur au réducteur, en cas de mauvaise fermeture le moteur peut créer des vibrations de l'arbre entraînant l'endommagement du motoréducteur.
- La première vidange doit être effectuée après 500 heures d'utilisations du motoréducteur, les vidanges suivantes doivent être effectuées au bout de 6000 heures d'utilisations.
- En cas de problèmes techniques, consultez le manuel d'utilisation fournis à la livraison du motoréducteur. En cas de problèmes particulier ou d'urgence, veuillez à contacter votre revendeur ou le centre technique I-MAK le plus proche.

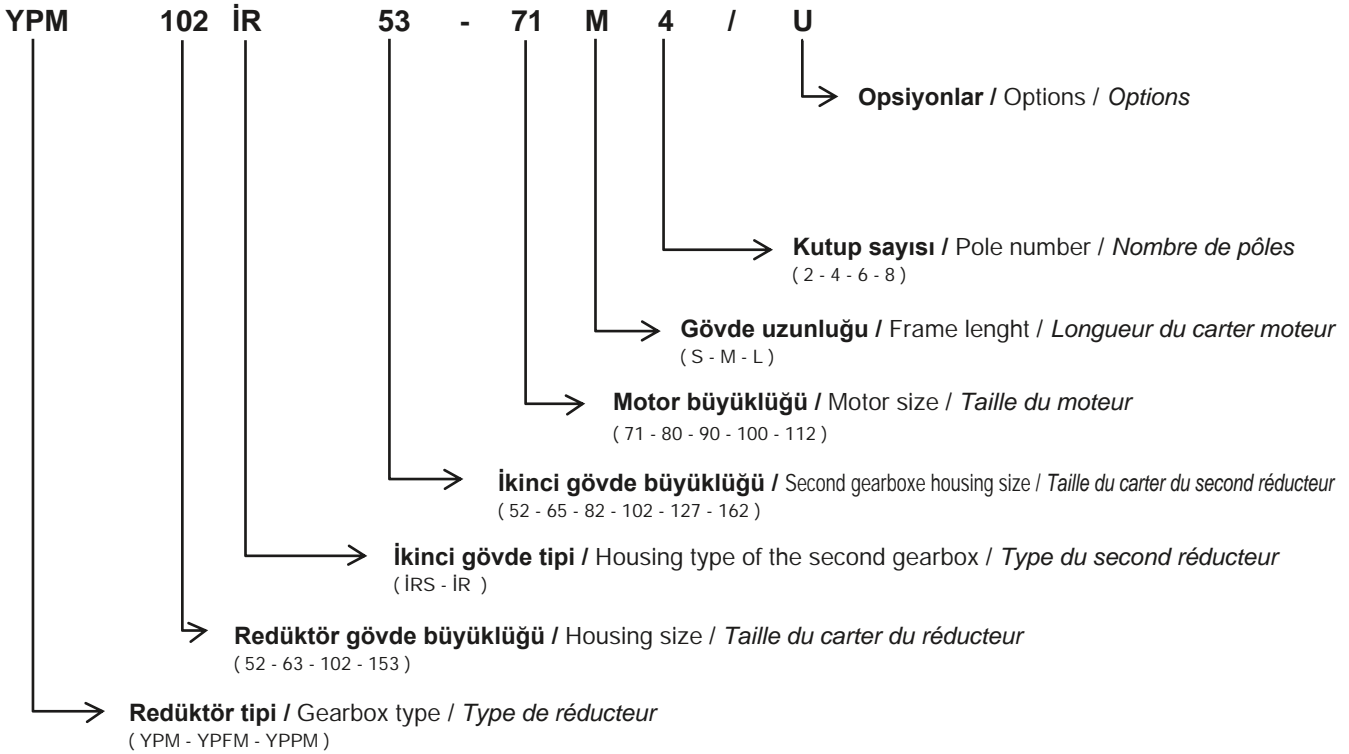
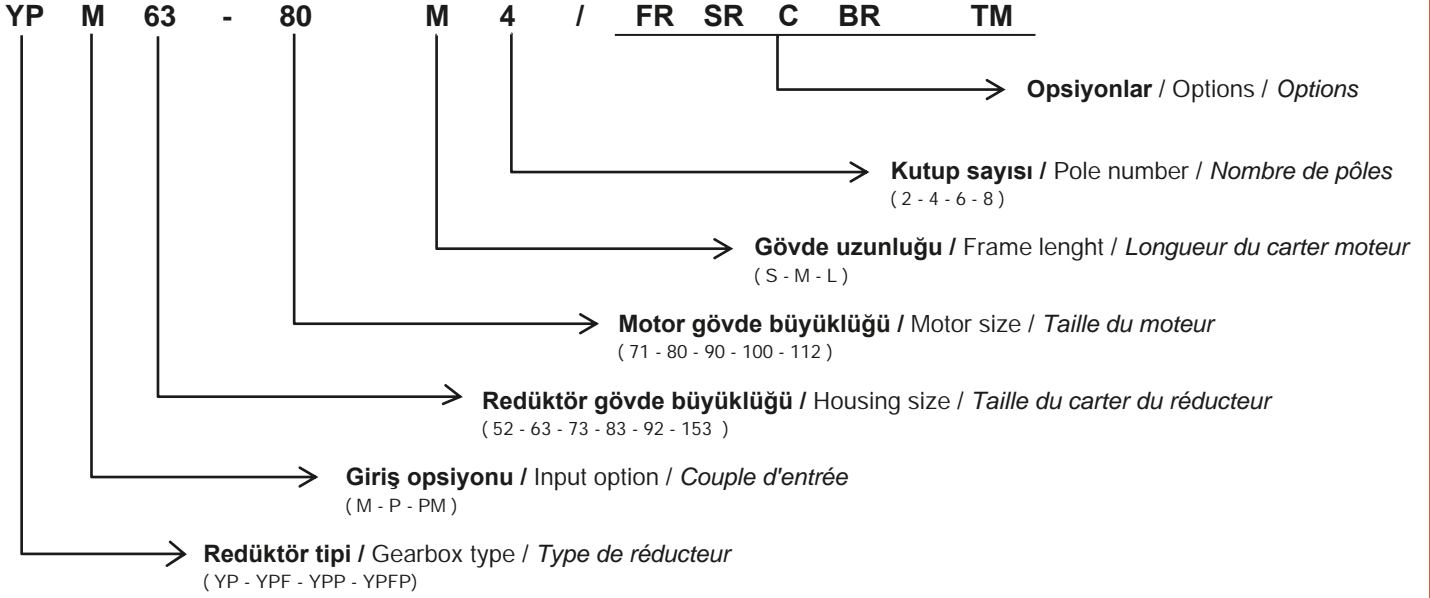



E. MEK

YP

CE

## YP Serisi Redüktörler Güç ve Devir Tabloları

---

YP Series Power Ratings and Output Speed  
*YP Series puissances et vitesses de sorties*



P <sub>1</sub> GÜÇ Power Puissance [kW] Hp	n <sub>2</sub> Çıkış Devri Output Speeds Vitesse de sortie [r.p.m]	İ Tahvil Ratio Rapport de réduction	S <sub>f</sub> Servis Faktörü Service Factor Service facteur	M <sub>2</sub> Çıkış Momenti Output Torque Couple de sortie [Nm]	F <sub>Q10</sub> Rad. Yük Over Loads Charges radiales [N]	Tip Type		 kg	
0,12 0,16	0,21	6715	1,02	5020	31500	YPM YPFM	103 İR 63 / 63 M 4a	129 130	200 220
	0,23	6042	1,09	4517	31500				
	0,25	5638	1,15	4215	31500				
	0,27	5097	1,28	3811	31500				
	0,33	4212	1,55	3149	31500				
	0,36	3845	1,69	2875	31500				
	0,41	3443	1,89	2574	31500				
	0,48	2887	2,20	2158	31500	YPM YPFM	102 İR 63 / 63 M 4a	129 130	195 215
	0,56	2481	2,40	1883	31500				
	0,63	2206	2,60	1674	31500				
	0,71	1976	3,00	1500	31500	YPM YPFM	93 İR 63 / 63 M 4a	123 124	122 125
	0,30	4717	0,98	3526	26800				
	0,32	4402	1,04	3291	26800				
	0,35	4005	1,14	2994	26800				
	0,38	3650	1,25	2729	26800				
	0,39	3571	1,29	2670	26800				
	0,42	3333	1,37	2492	26800				
	0,42	3350	1,29	2543	26800	YPM YPFM	92 İR 63 / 63 M 4a	123 124	119 122
	0,49	2843	1,45	2158	26800				
	0,51	2731	1,69	2073	26800				
	0,55	2548	1,80	1934	26800				
	0,62	2246	2,00	1705	26800				
	0,70	1996	2,30	1515	26800				
	0,78	1786	2,60	1356	26800				
	0,87	1607	2,80	1220	26800	YPPM YPPFM	83 İR 53 / 63 M 4a	117 118	96 102
	0,96	1453	3,10	1103	26800				
	1,1	1319	3,50	1001	26800				
	1,2	1200	3,80	911	26800				
	0,53	2626	0,80	1963	19500				
	0,60	2334	0,91	1745	19500				
	0,68	2061	1,03	1541	19500				
	0,76	1853	1,14	1385	19500	YPPM YPPFM	82 İR 53 / 63 M 4a	117 118	93 99
	0,86	1637	1,29	1224	19500				
	0,95	1469	1,44	1098	19500				
	0,99	1417	1,49	1075	19500				
	1,2	1134	1,74	861	19500				
	1,4	1024	1,93	777	19500				
	1,5	910	2,20	691	19500				
	1,7	816	2,40	619	19500	YPPM YPPFM	72 İR 53 / 63 M 4a	111 112	61 65
	1,9	736	2,70	559	19500				
	2,2	650	3,00	493	19500				
	0,91	1534	0,78	1164	13500				
1,0	1335	0,88	1013	13500					
1,2	1204	0,99	914	13500					
1,2	1187	0,98	901	13500					
1,3	1055	1,10	801	13500					
1,5	943	1,23	716	13500					
1,7	846	1,38	642	13500					
1,8	764	1,57	580	13500					
2,0	685	1,75	520	13500					
2,3	617	1,95	468	13500					
2,5	557	2,20	423	13500					
2,8	492	2,50	373	13500					
3,1	445	2,70	338	13500					
3,5	403	3,00	306	13500					
3,7	379	2,60	288	13500					





P <sub>1</sub> GÜÇ Power Puissance [kW] Hp	n <sub>2</sub> Çıkış Devri Output Speeds Vitesse de sortie [r.p.m]	İ Tahvil Ratio Rapport de réduction	S <sub>f</sub> Servis Faktörü Service Factor Service facteur	M <sub>2</sub> Çıkış Momenti Output Torque Couple de sortie [Nm]	F <sub>Q10</sub> Rad. Yük Over Loads Charges radiales [N]	Tip Type		 kg	
0,12 0,16	2,9	482,98	1,83	372	7450	YPPM YPFPM	74 / 63 M 4a	109 110	56 60
	3,3	428,50	2,00	330	7450				
	3,8	370,44	2,30	285	7450				
	4,7	299,38	3,00	231	7450				
	5,5	254,24	3,40	196	7450				
	2,2	643	0,80	488	7450	YPPM YPFPM	63 İR 42 / 63 M 4a	105 106	43 45
	2,3	610	0,84	463	7450				
	2,6	544	0,94	413	7450				
	3,1	450	1,14	342	7450				
	3,3	420	1,22	319	7450				
	3,8	364	1,41	276	7450				
	4,5	313	1,64	238	7450				
	4,9	285	1,80	216	7450				
	5,9	238	2,20	181	7450				
	6,2	225	2,60	171	7450				
	7,0	200	2,60	152	7450				
	8,5	164	3,10	124	7450				
	9,4	149	3,40	113	7450				
	10	135	4,10	102	7450				
	3,9	355	1,45	274	7450				
	5,0	279	1,85	215	7450				
	5,7	244	2,10	188	7450				
	7,1	197	2,60	152	7450				
	7,8	179	2,90	138	7450				
	8,6	162	3,20	125	7450	YPPM YPFPM	63 / 63 M 4a	103 104	32 34
	11	127	4,00	98	7450				
	7,4	190,17	2,70	149	7450				
	7,9	177,47	2,90	139	7450				
	8,4	166,10	3,10	130	7450				
	8,9	157,69	3,20	123	7450	YPM YPFM	53 İR 42 / 63 M 4a	101 102	30 32
	11	130,52	3,90	102	7450				
	4,0	352	0,88	267	4500				
4,4	316	0,98	240	4500					
4,9	284	1,09	216	4500					
5,4	257	1,20	195	4500					
6,2	225	1,24	171	4500					
7,1	198	1,55	150	4500	YPM YPFM	52 İR 42 / 63 M 4a	101 102	29 31	
8,0	175	1,75	133	4500					
7,2	194	1,34	149	4500					
8,1	173	1,51	133	4500					
9,1	154	1,69	119	4500					
10	138	1,88	106	4500					
11	125	2,10	96	4500					
13	112	2,30	86	4500	YPPM YPFPM	53 / 63 M 4a	99 100	19 21	
14	102	2,60	79	4500					
16	85	3,00	65	4500					
10	137,31	1,85	107	4500					
12	119,07	2,10	93	4500					
13	104,31	2,40	82	4500	YPM YPFM	103 İR 63 / 63 M 4b	129 130	201 221	
15	94,78	2,70	74	4500					
17	83,71	3,00	65	4500					
0,27	5097	0,85	5716	31500					
0,33	4212	1,03	4723	31500					
0,36	3845	1,13	4312	31500					
0,41	3443	1,26	3861	31500					
0,48	2887	1,47	3238	31500					



P <sub>1</sub> GÜÇ Power Puissance [kW] Hp	n <sub>2</sub> Çıkış Devri Output Speeds Vitesse de sortie [r.p.m]	İ Tahvil Ratio Rapport de réduction	S <sub>f</sub> Servis Faktörü Service Factor Service facteur	M <sub>2</sub> Çıkış Momenti Output Torque Couple de sortie [Nm]	F <sub>Q10</sub> Rad. Yük Over Loads Charges radiales [N]	Tip Type		 kg	
0,18 0,25	0,56	2481	1,60	2825	31500	YPM YPFM	102 İR 63 / 63 M 4b	129 130	196 216
	0,63	2206	1,73	2512	31500				
	0,71	1976	2,00	2250	31500				
	0,79	1779	2,10	2025	31500				
	0,87	1610	2,50	1833	31500				
	0,96	1462	2,50	1664	31500				
	1,1	1333	2,50	1518	31500				
	1,1	1218	2,50	1387	31500				
	1,3	1113	2,50	1267	31500				
	0,38	3650	0,83	4093	26800				
	0,39	3571	0,86	4005	26800				
	0,42	3333	0,91	3738	26800				
	0,42	3350	0,86	3814	26800	YPM YPFM	92 İR 63 / 63 M 4b	123 124	119 122
	0,49	2843	0,97	3237	26800				
	0,51	2731	1,13	3109	26800				
	0,55	2548	1,20	2901	26800				
	0,62	2246	1,33	2557	26800				
	0,70	1996	1,53	2272	26800				
	0,78	1786	1,73	2033	26800				
	0,87	1607	1,87	1830	26800				
	0,96	1453	2,10	1654	26800				
	1,1	1319	2,30	1502	26800				
	1,2	781,59	1,97	1405	7450	YPM YPFM	94 / 71 M 6a	121 122	117 120
	1,3	712,53	2,10	1281	7450				
	1,4	652,38	2,40	1173	7450				
	1,5	599,52	2,60	1078	7450				
	1,6	563,99	2,70	1014	7450				
	1,7	518,29	2,90	932	7450				
	0,86	1637	0,86	1836	19500	YPPM YPPFPM	83 İR 53 / 63 M 4b	117 118	96 102
	0,95	1469	0,96	1647	19500				
	0,99	1417	0,99	1613	19500				
	1,2	1134	1,16	1291	19500	YPPM YPPFPM	82 İR 53 / 63 M 4b	117 118	93 99
	1,4	663,81	1,18	1193	7450				
	1,5	594,20	1,32	1068	7450	YPM YPFM	84 / 71 M 6a	115 116	90 96
	1,7	528,44	1,49	950	7450				
	1,9	473,20	1,66	851	7450				
	2,1	663,81	1,85	767	7450	YPPM YPPFPM	84 / 63 M 4b	115 116	89 95
	2,4	594,20	2,00	687	7451				
	2,6	528,44	2,30	611	7452				
	3,0	473,20	2,60	547	7453				
	3,3	426,64	2,90	493	7454				
	3,7	242,30	3,20	442	19500				
4,3	209,47	3,80	382	19500	YPM YPFM	83 / 71 M 6a	113 114	87 93	
4,5	201,75	3,90	368	19500					
1,5	943	0,82	1074	13500					YPPM YPPFPM
1,7	846	0,92	963	13500					
1,8	764	1,05	870	13500	YPM YPFM	74 / 71 M 6a	109 110	58 62	
1,9	482,98	0,78	868	7450					
2,1	428,50	0,88	770	7450					
2,4	370,44	1,02	666	7450					
2,9	482,98	1,22	558	7450					
3,3	428,50	1,33	495	7451					
3,8	370,44	1,53	428	7452	YPPM YPPFPM	74 / 63 M 4b	109 110	57 61	
4,7	299,38	2,00	346	7453					
5,5	254,24	2,27	294	7454					
6,1	230,48	2,47	266	7455					



P <sub>1</sub> GÜÇ Power Puissance [kW] Hp	n <sub>2</sub> Çıkış Devri Output Speeds Vitesse de sortie [r.p.m]	İ Tahvil Ratio Rapport de réduction	S <sub>f</sub> Servis Faktörü Service Factor Service facteur	M <sub>2</sub> Çıkış Momenti Output Torque Couple de sortie [Nm]	F <sub>Q10</sub> Rad. Yük Over Loads Charges radiales [N]	Tip Type		 kg					
0,18 0,25	4,2	212,23	1,80	387	13500	YPPM YPFPM	73 / 71 M 6a	107 108	54 58				
	4,5	198,05	1,93	362	13500								
	4,9	185,37	2,10	338	13500								
	5,5	164,46	2,30	300	13500								
	6,2	145,66	2,60	266	13500								
	7,0	129,23	2,90	236	13500								
	6,6	212,23	2,80	249	13500	YPPM YPFPM	73 / 63 M 4b	107 108	53 57				
	7,1	198,05	2,90	232	13500								
	3,3	420	0,81	478	7450	YPPM YPFPM	63 İR 42 / 63 M 4b	105 106	43 45				
	3,8	364	0,94	414	7450								
	4,5	313	1,09	356	7450								
	4,9	285	1,20	324	7450								
	5,9	238	1,47	271	7450								
	6,2	225	1,53	256	7450								
	7,0	200	1,73	228	7450								
	8,5	164	2,10	187	7450								
	9,4	149	2,30	170	7450								
	10	135	2,70	154	7450								
	3,9	355	0,97	410	7450					YPPM YPFPM	62 İR 42 / 63 M 4b	105 106	42 44
	5,0	279	1,23	322	7450								
	5,7	244	1,40	282	7450								
	7,1	197	1,73	228	7450								
	7,8	179	1,93	207	7450								
	8,6	162	2,10	187	7450								
	11	127	2,70	147	7450	YPPM YPFPM	63 / 71 M 6a	103 104	34 36				
	4,7	190,17	1,15	347	7450								
	5,1	177,47	1,24	324	7450								
	5,4	166,10	1,33	303	7450								
	5,7	157,69	1,40	288	7450								
	6,9	130,52	1,67	238	7450								
	7,4	121,67	1,80	222	7450								
	8,5	105,48	2,07	193	7450								
	7,4	190,17	1,80	223	7450								
	7,9	177,47	1,93	208	7450								
	8,4	166,10	2,07	195	7450	YPPM YPFPM	63 / 63 M 4b	103 104	33 35				
	8,9	157,69	2,13	185	7450								
	11	130,52	2,60	153	7450								
	12	121,67	2,80	143	7450								
	13	105,48	3,20	124	7450								
	15	90,72	3,47	106	7450								
	5,4	257	0,80	293	4500	YPM YPFM	53 İR 42 / 63 M 4b	101 102	30 32				
	6,2	225	0,83	256	4500								
7,1	198	1,03	225	4500									
8,0	175	1,17	199	4500									
7,2	194	0,89	224	4500	YPM YPFM	52 İR 42 / 63 M 4b	101 102	30 32					
8,1	173	1,01	200	4500									
9,1	154	1,13	178	4500									
10	138	1,25	160	4500									
11	125	1,40	144	4500									
13	112	1,53	129	4500									
14	102	1,73	118	4500									
16	85	2,00	98	4500									
7,6	119,07	0,91	217	4500	YPM YPFM	53 / 71 M 6a	99 100	21 23					
8,6	104,31	1,04	190	4500									
9,5	94,78	1,15	173	4500									



P <sub>1</sub> GÜÇ Power Puissance [kW] Hp	n <sub>2</sub> Çıkış Devri Output Speeds Vitesse de sortie [r.p.m]	İ Tahvil Ratio Rapport de réduction	S <sub>f</sub> Servis Faktörü Service Factor Service facteur	M <sub>2</sub> Çıkış Momenti Output Torque Couple de sortie [Nm]	F <sub>Q10</sub> Rad. Yük Over Loads Charges radiales [N]	Tip Type		 kg					
<b>0,18</b> 0,25	10	137,31	1,23	161	4500	YPPM YPFPM	53 / 63 M 4b	99 100	20 22				
	12	119,07	1,40	140	4500								
	13	104,31	1,60	122	4500								
	15	94,78	1,80	111	4500								
	17	83,71	2,00	98	4500								
<b>0,25</b> 0,34	0,13	10878	0,85	16943	75000	YPM YPFM	143 İR 73 / 71 M 4a	141 142	502 537				
	0,14	9718	0,96	15136	75000								
	0,16	8730	1,07	13597	75000								
	0,19	7478	1,23	11647	75000								
	0,21	6672	1,36	10392	75000								
	0,24	5920	1,58	9220	75000								
	0,26	5288	1,73	8236	75000								
	0,28	5010	1,87	7803	75000								
	0,31	4475	2,00	6970	75000								
	0,35	4020	2,30	6261	75000								
	0,39	3628	2,50	5651	75000	YPM YPFM	123 İR 73 / 71 M 4a	135 136	292 322				
	0,43	3286	2,80	5118	75000								
	0,18	7633	0,79	11889	61500								
	0,21	6784	0,88	10566	61500								
	0,23	6061	0,96	9440	61500								
	0,26	5438	1,06	8470	61500								
	0,29	4895	1,20	7624	61500								
	0,32	4418	1,34	6881	61500								
	0,35	3996	1,49	6224	61500								
	0,39	3619	1,63	5637	61500								
	0,43	3281	1,82	5110	61500	YPM YPFM	103 İR 63 / 71 M 4a	129 130	202 222				
	0,36	3845	0,81	5989	31500								
	0,41	3443	0,91	5363	31500								
	0,48	2887	1,06	4497	31500								
	0,56	2481	1,15	3923	31500								
	0,63	2206	1,25	3488	31500								
	0,71	1976	1,44	3125	31500								
	0,79	1779	1,49	2813	31500								
	0,87	1610	1,82	2546	31500								
	0,96	1462	1,82	2312	31500					YPPM YPFPM	104 / 71 M 6b	127 128	196 216
	1,1	854,83	1,96	2135	7450								
	1,2	770,72	2,20	1925	7450								
	1,3	708,53	2,40	1769	7450								
	1,4	629,29	2,70	1571	7450								
	0,55	2548	0,86	4029	26800	YPM YPFM	92 İR 63 / 71 M 4a	123 124	120 123				
	0,62	2246	0,96	3551	26800								
	0,70	1996	1,10	3156	26800								
	0,78	1786	1,25	2824	26800								
	0,87	1607	1,34	2541	26800								
	0,96	1453	1,49	2298	26800								
1,1	1319	1,68	2086	26800									
1,2	1200	1,82	1897	26800									
1,2	781,59	1,42	1952	7450									
1,3	712,53	1,51	1779	7450	YPM YPFM					94 / 71 M 6b	121 122	118 121	
1,4	652,38	1,73	1629	7450									
1,5	599,52	1,87	1497	7450									
1,6	563,99	1,94	1408	7450									
1,7	518,29	2,09	1294	7450									
2,1	433,91	2,30	1084	7450									
1,8	781,59	2,20	1255	7450		YPM YPFM	94 / 71 M 4a	121 122	117 120				
2,0	712,53	2,40	1144	7450									
2,1	652,38	2,60	1047	7450									



P <sub>1</sub> GÜÇ Power Puissance [kW] Hp	n <sub>2</sub> Çıkış Devri Output Speeds Vitesse de sortie [r.p.m]	i Tahvil Ratio Rapport de réduction	S <sub>f</sub> Servis Faktörü Service Factor Service facteur	M <sub>2</sub> Çıkış Momenti Output Torque Couple de sortie [Nm]	F <sub>Q10</sub> Rad. Yük Over Loads Charges radiales [N]	Tip Type		 kg	
0,25 0,34	1,2	1134	0,83	1793	19500	YPM YPFM	82 İR 53 / 71 M 4a	117 118	94 100
	1,4	1024	0,93	1619	19500				
	1,5	910	1,06	1439	19500				
	1,7	816	1,15	1290	19500				
	1,9	736	1,30	1164	19500				
	1,4	663,81	0,85	1658	19500	YPM YPFM	84 / 71 M 6b	115 116	91 97
	1,5	594,20	0,95	1484	19500				
	1,7	528,44	1,07	1320	19500				
	1,9	473,20	1,20	1182	19500				
	2,1	663,81	1,33	1066	19500				
	2,4	594,20	1,44	954	19500	YPM YPFM	84 / 71 M 4a	115 116	90 96
	2,6	528,44	1,66	848	19500				
	3,0	473,20	1,87	760	19500				
	3,3	426,64	2,09	685	19500				
	3,6	384,21	2,30	617	19500				
	4,3	323,97	2,88	520	19500	YPM YPFM	83 / 71 M 6b	113 114	88 94
	3,7	242,30	2,30	614	19500				
	4,3	209,47	2,70	531	19500				
	4,5	201,75	2,80	511	19500				
	5,2	174,42	3,20	442	19500				
	2,4	591	0,83	935	13500	YPM YPFM	73 İR 52 / 71 M 4a	111 112	63 67
	2,7	526	0,93	832	13500				
	2,8	502	0,96	794	13500				
	2,0	685	0,84	1083	13500	YPM YPFM	72 İR 53 / 71 M 4a	111 112	62 66
	2,3	617	0,94	976	13500				
	2,5	557	1,06	881	13500				
	2,8	492	1,20	778	13500	YPM YPFM	74 / 71 M 4a	109 110	58 62
	2,9	482,98	0,88	775	13500				
	3,3	428,50	0,96	688	13500				
	3,8	370,44	1,10	595	13500				
	4,7	299,38	1,44	481	13500				
	5,5	254,24	1,63	408	13500	YPPM YPFPM	73 / 71 M 6b	107 108	55 59
	6,1	230,48	1,78	370	13500				
	4,2	212,23	1,30	538	13500				
	4,5	198,05	1,39	502	13500	YPM YPFM	73 / 71 M 6b	107 108	55 59
	4,9	185,37	1,49	470	13500				
	5,5	164,46	1,63	417	13500				
	6,2	145,66	1,87	369	13500				
	7,0	129,23	2,10	328	13500				
	6,6	212,23	2,00	346	13500	YPPM YPFPM	73 / 71 M 4a	107 108	54 58
	7,1	198,05	2,10	323	13500				
	7,6	185,37	2,30	302	13500				
8,5	164,46	2,60	268	13500	YPM YPFM	73 / 71 M 4a	107 108	54 58	
9,6	145,66	2,90	237	13500					
11	129,23	3,30	211	13500					
13	111,72	3,80	182	13500					
4,9	285	0,86	451	7450					YPM YPFM
5,9	238	1,05	376	7450					
6,2	225	1,10	356	7450					
7,0	200	1,25	316	7450					
8,5	164	1,49	259	7450					
9,4	149	1,63	236	7450	YPM YPFM	62 İR 42 / 71 M 4a	105 106	43 45	
10	135	1,97	213	7450					
5,0	279	0,89	448	7450					
5,7	244	1,00	392	7450					
7,1	197	1,25	316	7450					
7,8	179	1,39	287	7450	YPM YPFM	62 İR 42 / 71 M 4a	105 106	43 45	
8,6	162	1,54	260	7450					
11	127	1,92	204	7450					





P <sub>1</sub> GÜÇ Power Puissance [kW] Hp	n <sub>2</sub> Çıkış Devri Output Speeds Vitesse de sortie [r.p.m]	i Tahvil Ratio Rapport de réduction	S <sub>f</sub> Servis Faktörü Service Factor Service facteur	M <sub>2</sub> Çıkış Momenti Output Torque Couple de sortie [Nm]	F <sub>Q10</sub> Rad. Yük Over Loads Charges radiales [N]	Tip Type			
0,25 0,34	5,1	177,47	0,89	450	7450	YPPM YPFPM	63 / 71 M 6b	103 104	35 37
	5,4	166,10	0,96	421	7450	YPM YPFM	63 / 71 M 6b	103 104	35 37
	5,7	157,69	1,01	400	7450				
	6,9	130,52	1,20	331	7450				
	7,4	121,67	1,30	308	7450				
	8,5	105,48	1,49	267	7450				
	7,4	190,17	1,30	310	7450				
	7,9	177,47	1,39	289	7450	YPPM YPFPM	63 / 71 M 4a	103 104	34 36
	17	82,51	2,81	134	7450				
	20	68,90	3,30	112	7450				
	22	63,66	3,60	104	7450				
	8,4	166,10	1,49	271	7450	YPM YPFM	63 / 71 M 4a	103 104	34 36
	8,9	157,69	1,54	257	7450				
	11	130,52	1,87	213	7450				
	12	121,67	2,02	198	7450				
	13	105,48	2,30	172	7450				
	15	90,72	2,50	148	7450				
	21	65,14	3,50	106	7450				
	8,0	175	0,84	277	4500	YPM YPFM	53 İR 42 / 71 M 4a	101 102	31 33
	9,1	154	0,81	247	4500	YPM YPFM	52 İR 42 / 71 M 4a	101 102	31 33
	10	138	0,90	222	4500				
	11	125	1,01	201	4500				
	13	112	1,10	180	4500				
	14	102	1,25	164	4500				
	16	85	1,44	136	4500				
	12	119,07	1,01	194	4500				
	13	104,31	1,15	170	4500	YPM YPFM	53 / 71 M 4a	99 100	21 23
	15	94,78	1,30	154	4500				
	17	83,71	1,44	136	4500				
	19	74,40	1,63	121	4500				
	21	66,47	1,78	108	4500				
	23	59,64	2,02	97	4500				
	26	53,68	2,30	87	4500				
	29	48,45	2,52	79	4500				
	32	43,81	2,81	71	4500				
	35	39,46	3,02	64	4500				
	40	35,07	3,40	57	4500				
	45	31,33	3,80	51	4500				
	50	28,11	4,30	46	4500				
	55	25,30	4,70	41	4500				
	61	22,84	5,10	37	4500				
	54	25,75	4,70	43	4250	YPPM YPFPM	52 / 71 M 4a	99 100	19 21
63	22,33	5,40	37	4250	YPM YPFM	52 / 71 M 4a	99 100	19 21	
72	19,56	6,30	32	4250					
81	17,27	6,90	29	4250					
91	15,35	7,80	25	4250					
102	13,72	8,70	23	3850					
114	12,31	9,90	20	3850					
126	11,08	10,80	18	3850					
140	10,00	11,90	17	3850					
155	9,04	13,20	15	3850					
193	7,24	11,30	12	3500					
217	6,47	12,00	11	4250					
241	5,80	13,20	10	4250					





P <sub>1</sub> GÜÇ Power Puissance [kW] Hp	n <sub>2</sub> Çıkış Devri Output Speeds Vitesse de sortie [r.p.m]	İ Tahvil Ratio Rapport de réduction	S <sub>f</sub> Servis Faktörü Service Factor Service facteur	M <sub>2</sub> Çıkış Momenti Output Torque Couple de sortie [Nm]	F <sub>Q10</sub> Rad. Yük Over Loads Charges radiales [N]	Tip Type			kg
0,25 0,34	268	5,22	13,80	9	4250	YPM YPFM	52 / 71 M 4a	99	19
	297	4,71	14,40	8	4250			100	21
	328	4,26	15,60	7	3850				
0,37 0,5	0,19	7478	0,83	17238	75000	YPM YPFM	143 İR 73 / 71 M 4b	141	503
	0,21	6672	0,92	15380	75000			142	538
	0,24	5920	1,07	13646	75000				
	0,26	5288	1,17	12189	75000				
	0,28	5010	1,26	11549	75000				
	0,31	4475	1,36	10315	75000				
	0,35	4020	1,55	9267	75000				
	0,39	3628	1,70	8363	75000				
	0,43	3286	1,90	7575	75000				
	0,47	2985	2,10	6881	75000				
	0,51	2720	2,30	6270	75000				
	0,58	2404	2,50	5542	75000				
	0,64	2177	2,70	5018	75000				
	0,32	4418	0,91	10184	61500	YPM YPFM	123 İR 73 / 71 M 4b	135	293
	0,35	3996	1,00	9211	61500			136	323
	0,39	3619	1,10	8342	61500				
	0,43	3281	1,23	7563	61500				
	0,63	2206	0,84	5163	31500	YPM YPFM	102 İR 63 / 71 M 4b	129	198
	0,71	1976	0,97	4624	31500			130	218
	0,79	1779	1,00	4163	31500				
	0,87	1610	1,23	3768	31500				
	0,96	1462	1,23	3421	31500				
	1,1	1333	1,23	3120	31500				
	1,1	1218	1,23	2850	31500				
	1,3	1113	1,23	2605	31500				
	1,5	954	2,10	2233	31500	YPM YPFM	104 / 80 M 6a	127	199
	1,1	854,83	1,32	3159	31500			128	219
	1,2	770,72	1,49	2848	31500				
	1,3	708,53	1,62	2619	31500				
	1,4	629,29	1,82	2326	31500	YPPM YPPFM	104 / 71 M 4b	127	197
	1,6	854,83	2,00	2031	31500			128	217
	1,8	770,72	2,30	1831	31500				
2,0	708,53	2,50	1683	31500					
2,2	629,29	2,80	1495	31500	YPM YPFM	92 İR 63 / 71 M 4b	123	121	
2,5	563,83	3,10	1340	31500			124	124	
0,78	1786	0,84	4180	26800					
0,87	1607	0,91	3761	26800					
0,96	1453	1,00	3400	26800	YPM YPFM	94 / 80 M 6a	121	120	
1,1	1319	1,14	3087	26800			122	123	
1,2	781,59	0,96	2889	7450					
1,3	712,53	1,02	2633	7450					
1,4	652,38	1,17	2411	7450					
1,5	599,52	1,26	2216	7450					
1,6	563,99	1,31	2084	7450					
1,7	518,29	1,41	1915	7450					
2,1	433,91	1,56	1604	7450	YPM YPFM	94 / 71 M 4b	121	118	
1,8	781,59	1,49	1857	7450			122	121	
2,0	712,53	1,62	1693	7450					
2,1	652,38	1,76	1550	7450					
2,3	599,52	1,96	1424	7450					
2,5	563,99	2,03	1340	7450					
2,7	518,29	2,23	1231	7450					
3,2	433,91	2,36	1031	7450					
3,6	385,58	2,64	916	7450					



P <sub>1</sub> GÜÇ Power Puissance [kW] Hp	n <sub>2</sub> Çıkış Devri Output Speeds Vitesse de sortie [r.p.m]	i Tahvil Ratio Rapport de réduction	S <sub>f</sub> Servis Faktörü Service Factor Service facteur	M <sub>2</sub> Çıkış Momenti Output Torque Couple de sortie [Nm]	F <sub>Q10</sub> Rad. Yük Over Loads Charges radiales [N]	Tip Type		 kg	
0,37 0,5	3,1	285,83	2,60	1072	26800	YPM YPFM	93 / 80 M 6a	119 120	112 115
	3,6	252,35	3,00	947	26800				
	3,8	235,39	3,20	883	26800				
	4,1	222,00	3,40	833	26800				
	4,2	213,04	3,60	799	26800				
	4,5	198,72	3,70	746	26800				
	1,9	473,20	0,81	1749	19000	YPM YPFM	84 / 80 M 6a	115 116	93 99
	2,1	663,81	0,90	1577	19000	YPM YPFM	84 / 71 M 4b	115 116	91 97
	2,4	594,20	0,97	1412	19000				
	2,6	528,44	1,12	1256	19000				
	3,0	473,20	1,26	1124	19000				
	3,3	426,64	1,41	1014	19000				
	3,6	384,21	1,56	913	19000				
	4,3	323,97	1,95	770	19000				
	4,8	288,84	2,16	686	19000				
	5,4	259,33	2,43	616	19000	YPM YPFM	83 / 80 M 6a	113 114	90 96
	3,7	242,30	1,55	909	19000				
	4,3	209,47	1,85	786	19000				
	4,5	201,75	1,90	757	19000	YPM YPFM	83 / 71 M 4b	113 114	88 94
	5,2	174,42	2,20	654	19000				
	9,0	156,13	0,00	377	19000	YPM YPFM	72 İR 53 / 71 M 4b	111 112	63 67
	9,1	153,81	0,00	371	19000				
	10	137,68	0,00	332	19000	YPM YPFM	74 / 71 M 4b	109 110	59 63
	2,8	492	0,81	1151	13500				
	3,1	445	0,88	1041	13500	YPM YPFM	73 / 80 M 6a	107 108	57 61
	3,5	403	0,97	943	13500				
	3,8	370,44	0,75	880	7450	YPM YPFM	73 / 80 M 6a	107 108	57 61
	4,7	299,38	0,97	711	7451				
	5,5	254,24	1,10	604	7452	YPM YPFM	73 / 71 M 4b	107 108	55 59
	6,1	230,48	1,20	548	7453				
	4,2	212,23	0,88	796	13500	YPPM YPFPM	63 İR 42 / 71 M 4b	105 106	45 47
	4,5	198,05	0,97	743	13500				
	4,9	185,37	1,00	696	13500	YPM YPFM	62 İR 42 / 71 M 4b	105 106	44 46
	5,5	164,46	1,10	617	13500				
	6,2	145,66	1,26	547	13500	YPM YPFM	63 / 80 M 6a	103 104	37 39
	7,0	129,23	1,43	485	13500				
	6,6	212,23	1,35	512	13500	YPPM YPFPM	73 / 71 M 4b	107 108	55 59
	7,1	198,05	1,42	478	13500				
	7,6	185,37	1,55	447	13500	YPM YPFM	73 / 71 M 4b	107 108	55 59
	8,5	164,46	1,75	397	13500				
	9,6	145,66	1,96	351	13500	YPM YPFM	63 İR 42 / 71 M 4b	105 106	45 47
	11	129,23	2,20	312	13500				
13	111,72	2,50	269	13500	YPM YPFM	62 İR 42 / 71 M 4b	105 106	44 46	
16	90,29	3,50	218	13500					
18	76,73	4,30	185	13500	YPM YPFM	63 / 80 M 6a	103 104	37 39	
6,2	225	0,84	527	7320					
7,0	200	1,00	468	7320	YPM YPFM	63 İR 42 / 71 M 4b	105 106	45 47	
8,5	164	1,10	384	7320					
9,4	149	1,33	349	7320	YPM YPFM	62 İR 42 / 71 M 4b	105 106	44 46	
7,1	197	0,84	468	7320					
7,8	179	0,94	425	7320	YPM YPFM	63 / 80 M 6a	103 104	37 39	
8,6	162	1,04	385	7320					
11	127	1,30	302	7320	YPM YPFM	63 / 80 M 6a	103 104	37 39	
6,9	130,52	0,81	490	7320					
7,4	121,67	0,88	457	7320	YPM YPFM	63 / 80 M 6a	103 104	37 39	
8,5	105,48	1,00	396	7320					





P <sub>1</sub> GÜÇ Power Puissance [kW] Hp	n <sub>2</sub> Çıkış Devri Output Speeds Vitesse de sortie [r.p.m]	İ Tahvil Ratio Rapport de réduction	S <sub>f</sub> Servis Faktörü Service Factor Service facteur	M <sub>2</sub> Çıkış Momenti Output Torque Couple de sortie [Nm]	F <sub>Q10</sub> Rad. Yük Over Loads Charges radiales [N]	Tip Type		 kg				
0,37 0,5	7,4	190,17	0,88	459	7320	YPPM YPFPM	63 / 71 M 4b	103 104	35 37			
	7,9	177,47	0,94	428	7320							
	17	82,51	1,90	199	7300							
	20	68,90	2,23	166	7300							
	22	63,66	2,43	154	7160							
	24	58,09	2,64	140	7160							
	32	43,37	3,60	105	7160	YPM YPFM	63 / 71 M 4b	103 104	35 37			
	8,4	166,10	1,01	401	7320							
	8,9	157,69	1,04	380	7320							
	11	130,52	1,26	315	7320							
	12	121,67	1,36	293	7320							
	13	105,48	1,56	254	7300							
	15	90,72	1,69	219	7300	YPM YPFM	53 / 71 M 4b	99 100	22 24			
	21	65,14	2,36	157	7160							
	27	52,64	2,91	127	7160							
	29	47,69	3,30	115	7160							
	15	94,78	0,88	229	4500							
	17	83,71	0,97	202	4500							
	19	74,40	1,10	179	4500	YPM YPFM	52 / 71 M 4b	99 100	20 22			
	21	66,47	1,20	160	4500							
	23	59,64	1,36	144	4500							
	26	53,68	1,56	129	4500							
	29	48,45	1,70	117	4500							
	32	43,81	1,90	106	4500							
	35	39,46	2,04	95	4500	YPM YPFM	52 / 71 M 4b	99 100	20 22			
	40	35,07	2,30	85	4500							
	45	31,33	2,57	76	4500							
	50	28,11	2,91	68	4500							
	55	25,30	3,18	61	4500							
	61	22,84	3,45	55	4500							
	54	25,75	3,18	63	3900	YPM YPFM	52 / 71 M 4b	99 100	20 22			
	63	22,33	3,65	55	3900							
72	19,56	4,26	48	3900								
81	17,27	4,66	42	3900								
91	15,35	5,27	38	3900								
102	13,72	5,88	34	3500								
114	12,31	6,69	30	3500	YPM YPFM	52 / 71 M 4b	99 100	20 22				
126	11,08	7,30	27	3500								
140	10,00	8,04	24	3500								
155	9,04	8,92	22	3500								
193	7,24	7,64	18	3150								
217	6,47	8,11	16	3150								
241	5,80	8,92	14	3150	YPM YPFM	143 İR 73 / 80 M 4a	141 142	504 539				
268	5,22	9,32	13	3150								
297	4,71	9,73	12	3150								
328	4,26	10,54	10	3150								
0,21	6672	0,82	22862	110000					YPM YPFM	153 İR 83 / 80 M 4a	149 150	864 904
0,24	5854	0,94	20059	110000								
0,27	5225	1,05	17904	110000								
0,30	4689	1,17	16067	110000								
0,45	3094	1,76	10602	110000								
0,50	2815	1,94	9646	110000								
0,60	2343	2,30	8028	110000	YPM YPFM	143 İR 73 / 80 M 4a	141 142	504 539				
0,26	5288	0,79	18120	75000								
0,28	5010	0,85	17167	75000								
0,31	4475	0,92	15334	75000								
0,35	4020	1,05	13775	75000								



P <sub>1</sub> GÜÇ Power Puissance [kW] Hp	n <sub>2</sub> Çıkış Devri Output Speeds Vitesse de sortie [r.p.m]	İ Tahvil Ratio Rapport de réduction	S <sub>f</sub> Servis Faktörü Service Factor Service facteur	M <sub>2</sub> Çıkış Momenti Output Torque Couple de sortie [Nm]	F <sub>Q10</sub> Rad. Yük Over Loads Charges radiales [N]	Tip Type		 kg	
0,55 0,75	0,39	3628	1,15	12431	75000	YPM YPFM	143 İR 73 / 80 M 4a	141 142	504 539
	0,43	3286	1,27	11260	75000				
	0,47	2985	1,41	10228	75000				
	0,51	2720	1,54	9320	75000				
	0,58	2404	1,67	8237	75000				
	0,64	2177	1,83	7460	75000				
	0,52	2683	1,54	9333	75000	YPM YPFM	143 İR 72 / 80 M 4a	141 142	502 537
	0,58	2408	1,70	8377	75000				
	0,72	1936	2,10	6735	75000				
	0,87	1617	2,50	5625	75000				
	0,98	1423	2,80	4950	75000				
	1,1	1262	3,20	4390	75000				
	0,47	2971	0,89	10335	61500	YPM YPFM	123 İR 72 / 80 M 4a	135 136	293 323
	0,53	2641	1,00	9187	61500				
	0,59	2368	1,11	8238	61500				
	0,65	2138	1,23	7437	61500				
	0,72	1943	1,35	6759	61500				
	0,79	1774	1,48	6171	61500				
	0,86	1628	1,62	5663	61500	YPM YPFM	124 / 80 M 6b	133 134	291 321
	0,98	1428	1,79	4968	61500				
	1,1	1290	2,00	4488	61500				
	1,2	761,08	1,75	4181	61500				
	1,3	687,35	1,94	3776	61500				
	1,4	624,54	2,10	3431	61500				
	0,87	1610	0,83	5601	31500	YPM YPFM	102 İR 63 / 80 M 4a	129 130	200 220
	0,96	1462	0,83	5086	31500				
	1,1	1333	0,83	4637	31500				
	1,1	1218	0,83	4237	31500				
	1,3	1113	0,83	3872	31500				
	1,1	854,83	0,89	4696	31500				
	1,2	770,72	1,00	4234	31500	YPM YPFM	104 / 80 M 6b	127 128	200 220
	1,3	708,53	1,09	3892	31500				
	1,4	629,29	1,23	3457	31500				
	1,6	854,83	1,35	3019	31500				
	1,8	770,72	1,55	2722	31500				
	2,0	708,53	1,68	2502	31500				
	2,2	629,29	1,88	2222	31500	YPM YPFM	104 / 80 M 4a	127 128	198 218
	2,5	563,83	2,09	1991	31500				
	2,8	508,84	2,35	1797	31500				
	3,0	462,00	2,56	1632	31500				
	3,6	392,00	3,03	1384	31500				
	4,0	350,76	3,30	1239	31500				
	1,2	1200	0,83	4174	26800	YPM YPFM	92 İR 63 / 80 M 4a	123 124	123 126
	1,3	1096	0,92	3813	26800				
1,4	652,38	0,79	3584	26000					
1,5	599,52	0,85	3294	26000	YPM YPFM	94 / 80 M 6b	121 122	122 125	
1,6	563,99	0,88	3098	26000					
1,7	518,29	0,95	2847	26000					
2,1	433,91	1,05	2384	26000					
1,8	781,59	1,00	2760	26000					
2,0	712,53	1,09	2516	26000					
2,1	652,38	1,18	2304	26000	YPM YPFM	94 / 80 M 4a	121 122	120 123	
2,3	599,52	1,32	2117	26000					
2,5	563,99	1,36	1992	26000					
2,7	518,29	1,50	1830	26000					
3,2	433,91	1,59	1532	26000					
3,6	385,58	1,77	1362	26000					
3,9	359,21	2,18	1269	26000					
4,4	320,26	2,45	1131	26000					



P <sub>1</sub> GÜÇ Power Puissance [kW] Hp	n <sub>2</sub> Çıkış Devri Output Speeds Vitesse de sortie [r.p.m]	i Tahvil Ratio Rapport de réduction	S <sub>f</sub> Servis Faktörü Service Factor Service facteur	M <sub>2</sub> Çıkış Momenti Output Torque Couple de sortie [Nm]	F <sub>Q10</sub> Rad. Yük Over Loads Charges radiales [N]	Tip Type		 kg	
0,55 0,75	3,1	285,83	1,75	1594	26000	YPM YPFM	93 / 80 M 6b	119 120	113 116
	3,6	252,35	2,00	1407	26000				
	3,8	235,39	2,20	1313	26000				
	4,1	222,00	2,30	1238	26000				
	4,2	213,04	2,40	1188	26000				
	4,5	198,72	2,50	1108	26000				
	4,9	285,83	2,70	1025	26000	YPM YPFM	93 / 80 M 4a	119 120	112 115
	5,5	252,35	3,10	905	26000				
	5,9	235,39	3,20	844	26000				
	6,3	222,00	3,50	796	26000				
	6,6	213,04	3,70	764	26000				
	2,7	525	0,83	1826	19000				
	2,9	475	0,92	1652	19000				
	3,0	473,20	0,85	1671	18500	YPM YPFM	84 / 80 M 4a	115 116	93 99
	3,3	426,64	0,95	1507	18500				
	3,6	384,21	1,05	1357	18500				
	4,3	323,97	1,31	1144	18500				
	4,8	288,84	1,45	1020	18500				
	5,4	259,33	1,64	916	18500				
	3,7	242,30	1,05	1351	18500	YPM YPFM	83 / 80 M 6b	113 114	91 97
	4,3	209,47	1,24	1168	18500				
	4,5	201,75	1,28	1125	18500				
	5,2	174,42	1,47	973	18500				
	5,8	242,30	1,68	869	18500				
	6,7	209,47	1,88	751	18500				
	6,9	201,75	2,00	723	18500	YPM YPFM	83 / 80 M 4a	113 114	90 96
	8,0	174,42	2,30	625	18500				
	9,0	156,13	2,60	560	18500				
	9,1	153,81	2,60	551	18500				
	10	137,68	2,90	494	18500				
	11	122,44	3,30	439	18500				
	13	109,64	3,60	393	18500	YPM YPFM	73 İR 52 / 80 M 4a	111 112	66 70
	14	98,86	4,00	354	18500				
	5,3	264	0,84	918	13500				
	5,7	247	0,89	859	13500	YPM YPFM	72 İR 53 / 80 M 4a	111 112	65 69
	4,3	325	0,81	1131	13500				
	4,7	295	0,89	1026	13500				
	5,1	273	0,92	950	13500				
	5,3	263	1,55	915	13500				
	5,7	244	1,55	849	13500				
	6,1	230,48	0,81	814	7450	YPM YPFM	74 / 80 M 4a	109 110	60 64
	4,2	212,23	0,00	1184	13500				
4,5	198,05	0,00	1105	13500	YPM YPFM	73 / 80 M 6b	107 108	58 62	
6,6	212,23	0,90	761	13000					
7,1	198,05	0,95	710	13000	YPPM YPPFM	73 / 80 M 4a	107 108	57 61	
7,6	185,37	1,05	665	13000					
8,5	164,46	1,18	590	13000	YPM YPFM	73 / 80 M 4a	107 108	57 61	
9,6	145,66	1,32	522	13000					
11	129,23	1,50	463	13000					
13	111,72	1,72	401	13000					
16	90,29	2,40	324	13000					
18	76,73	2,90	275	13000					
20	69,51	3,20	249	13000					
22	63,22	3,50	227	13000					
27	52,79	4,20	189	13000					



P <sub>1</sub> GÜÇ Power Puissance [kW] Hp	n <sub>2</sub> Çıkış Devri Output Speeds Vitesse de sortie [r.p.m]	İ Tahvil Ratio Rapport de réduction	S <sub>f</sub> Servis Faktörü Service Factor Service facteur	M <sub>2</sub> Çıkış Momenti Output Torque Couple de sortie [Nm]	F <sub>Q10</sub> Rad. Yük Over Loads Charges radiales [N]	Tip Type		 kg			
0,55 0,75	11	130,52	0,85	468	7250	YPM YPFM	63 / 80 M 4a	103 104	37 39		
	12	121,67	0,92	436	7250						
	13	105,48	1,05	378	7250						
	15	90,72	1,13	325	7100						
	17	82,51	1,28	296	7100						
	20	68,90	1,50	247	7100						
	21	65,14	1,59	234	7100						
	22	63,66	1,64	228	7100						
	24	58,09	1,77	208	6900						
	27	52,64	1,95	189	6900						
	29	47,69	2,22	171	6900						
	32	43,37	2,42	156	6900						
	39	36,22	2,89	130	6720						
	46	30,54	3,36	109	6720						
	0,75 1,1	21	66,47	0,81	238	4250	YPM YPFM	53 / 80 M 4a	99 100	24 26	
		23	59,64	0,92	214	4250					
		26	53,68	1,05	192	4250					
		29	48,45	1,15	174	4250					
		32	43,81	1,28	157	4250					
		35	39,46	1,37	141	4250					
		40	35,07	1,55	126	4250					
		45	31,33	1,73	112	4250					
		0,75 1,1	50	28,11	1,95	101	4250	YPPM YPFPM	52 / 80 M 4a	99 100	22 24
			55	25,30	2,14	91	4250				
			61	22,84	2,32	82	4250				
			54	25,75	2,14	94	3710				
			63	22,33	2,45	81	3710				
			72	19,56	2,86	71	3710				
			81	17,27	3,14	63	3710				
			91	15,35	3,55	56	3710				
			102	13,72	3,95	50	3310				
			114	12,31	4,50	45	3310				
126	11,08		4,91	40	3310						
140	10,00		5,41	36	3310						
155	9,04		6,00	33	3310						
163	8,59		6,18	31	3000						
184	7,60		7,09	28	3000						
193	7,24		5,14	26	3000						
217	6,47		5,45	24	3000						
241	5,80		6,00	21	3000						
268	5,22	6,27	19	3000							
297	4,71	6,55	17	3000							
328	4,26	7,09	16	3000							
346	4,05	10,36	15	3000							
391	3,58	10,91	13	3000							
0,75 1,1	0,27	5225	0,77	24414	110000	YPM YPFM	153 İR 83 / 80 M 4b	149 150	867 907		
	0,30	4689	0,86	21910	110000						
	0,45	3094	1,29	14457	110000						
	0,50	2815	1,42	13153	110000						
	0,75 1,1	0,60	2343	1,70	10948	110000	YPM YPFM	152 İR 83 / 80 M 4b	149 150	857 897	
		0,63	2222	1,80	10541	110000					
		0,70	1988	2,00	9430	110000					
		0,78	1791	2,20	8496	110000					
		0,39	3628	0,84	16952	75000	YPM YPFM	143 İR 73 / 80 M 4b	141 142	507 542	
		0,43	3286	0,93	15354	75000					
0,47	2985	1,03	13948	75000							



P <sub>1</sub> GÜÇ Power Puissance [kW] Hp	n <sub>2</sub> Çıkış Devri Output Speeds Vitesse de sortie [r.p.m]	İ Tahvil Ratio Rapport de réduction	S <sub>f</sub> Servis Faktörü Service Factor Service facteur	M <sub>2</sub> Çıkış Momenti Output Torque Couple de sortie [Nm]	F <sub>Q10</sub> Rad. Yük Over Loads Charges radiales [N]	Tip Type			kg
0,75 1,1	0,51	2720	1,13	12709	75000	YPM YPFM	143 İR 73 / 80 M 4b	141	507
	0,58	2404	1,22	11233	75000			142	542
	0,64	2177	1,34	10172	75000	YPM YPFM	143 İR 72 / 80 M 4b	141	505
	0,52	2683	1,13	12727	75000			142	537
	0,58	2408	1,25	11423	75000	YPPM YPFPM	144 / 90 S 6a	139	534
	0,72	1936	1,56	9184	75000			140	569
	0,87	1617	1,87	7671	75000	YPM YPFM	123 İR 72 / 80 M 4b	135	295
	0,98	1423	2,10	6750	75000			136	325
	1,1	851	1,88	6375	75000	YPM YPFM	124 / 90 S 6a	133	293
	1,3	710,79	2,20	5325	75000			134	323
	1,4	625,48	2,80	4686	75000	YPM YPFM	124 / 80 M 4b	133	292
	0,59	2368	0,81	11233	61500			134	322
	0,65	2138	0,90	10142	61500	YPM YPFM	104 / 90 S 6a	127	203
	0,72	1943	0,99	9217	61500			128	223
	0,79	1774	1,08	8415	61500	YPM YPFM	104 / 80 M 4b	127	201
	0,86	1628	1,19	7723	61500			128	221
	0,98	1428	1,31	6774	61500	YPPM YPFPM	103 / 90 S 6a	125	196
	1,1	1290	1,47	6119	61500			126	216
	1,2	761,08	1,28	5702	61500	YPM YPFM	92 İR 63 / 80 M 4b	123	125
	1,3	687,35	1,42	5149	61500			124	128
	1,4	624,54	1,54	4679	61500	YPM YPFM	94 / 90 S 6a	121	124
	1,6	567,16	1,69	4249	61500			122	127
	1,8	761,08	2,00	3665	61500	YPM YPFM	94 / 80 M 4b	121	123
	2,0	687,35	2,20	3310	61500			122	126
	2,2	624,54	2,40	3008	61500	YPM YPFM	94 / 80 M 4b	121	123
	1,4	629,29	0,90	4714	31250			122	126
	1,6	854,83	0,99	4117	31250	YPM YPFM	94 / 80 M 4b	121	123
	1,8	770,72	1,13	3712	31250			122	126
	2,0	708,53	1,23	3412	31250	YPM YPFM	94 / 80 M 4b	121	123
	2,2	629,29	1,38	3031	31250			122	126
	2,5	563,83	1,53	2715	31250	YPM YPFM	94 / 80 M 4b	121	123
	2,8	508,84	1,73	2451	31250			122	126
	3,0	462,00	1,87	2225	31250	YPM YPFM	94 / 80 M 4b	121	123
	3,6	392,00	2,22	1888	31250			122	126
	4,0	350,76	2,42	1689	31250	YPM YPFM	94 / 80 M 4b	121	123
	4,8	293,55	2,94	1414	31250			122	126
	5,4	258,69	3,30	1246	31250	YPM YPFM	94 / 80 M 4b	121	123
	3,3	270,11	2,00	2054	31250			122	126
	3,6	251,95	2,10	1916	31250	YPPM YPFPM	103 / 90 S 6a	125	196
	4,1	221,37	2,40	1684	31250			126	216
4,6	196,61	2,80	1495	31250	YPM YPFM	92 İR 63 / 80 M 4b	123	125	
5,0	180,75	3,00	1375	31250			124	128	
5,6	160,54	3,20	1221	31250	YPM YPFM	94 / 90 S 6a	121	124	
1,6	863	0,85	4094	25000			122	127	
1,8	772	0,95	3662	25000	YPM YPFM	94 / 90 S 6a	121	124	
2,0	695	1,04	3297	25000			122	127	
2,1	433,91	0,77	3251	25000	YPM YPFM	94 / 90 S 6a	121	124	
2,0	712,53	0,80	3432	25000			122	127	
2,1	652,38	0,87	3142	25000	YPM YPFM	94 / 80 M 4b	121	123	
2,3	599,52	0,97	2887	25000			122	126	
2,5	563,99	1,00	2716	25000	YPM YPFM	94 / 80 M 4b	121	123	
2,7	518,29	1,10	2496	25000			122	126	
3,2	433,91	1,17	2090	25000	YPM YPFM	94 / 80 M 4b	121	123	
3,6	385,58	1,30	1857	25000			122	126	
3,9	359,21	1,60	1730	25000	YPM YPFM	94 / 80 M 4b	121	123	
4,4	320,26	1,80	1542	25000			122	126	



P <sub>1</sub> GÜÇ Power Puissance [kW] Hp	n <sub>2</sub> Çıkış Devri Output Speeds Vitesse de sortie [r.p.m]	i Tahvil Ratio Rapport de réduction	S <sub>f</sub> Servis Faktörü Service Factor Service facteur	M <sub>2</sub> Çıkış Momenti Output Torque Couple de sortie [Nm]	F <sub>Q10</sub> Rad. Yük Over Loads Charges radiales [N]	Tip Type			 kg
0,75 1,1	3,1	285,83	1,28	2174	24000	YPPM YPFPM	93 / 90 S 6a	119 120	117 120
	3,6	252,35	1,48	1919	24000	YPM YPFM	93 / 90 S 6a	119 120	117 120
	3,8	235,39	1,58	1790	24000				
	4,1	222,00	1,68	1688	24000				
	4,2	213,04	1,76	1620	24000				
	4,5	198,72	1,83	1511	24000				
	4,9	285,83	2,00	1398	24000	YPM YPFM	93 / 80 M 4b	119 120	114 117
	5,5	252,35	2,30	1234	24000				
	5,9	235,39	2,40	1151	24000				
	6,3	222,00	2,60	1085	24000				
	6,6	213,04	2,70	1042	24000				
	7,0	198,72	2,90	972	24000	YPM YPFM	82 İR 53 / 80 M 4b	117 118	99 105
	3,7	382	0,83	1812	18500				
	4,1	343	0,93	1627	18500	YPM YPFM	82 İR 52 / 80 M 4b	117 118	99 105
	3,6	389	0,87	1873	18500	YPM YPFM			
	4,0	347	0,97	1671	18500	YPM YPFM	84 / 80 M 4b	115 116	96 102
	4,3	323,97	0,96	1560	18000	YPM YPFM			
	4,8	288,84	1,07	1391	18000	YPM YPFM	83 / 90 S 6a	113 114	95 101
	5,4	259,33	1,20	1249	18000				
	3,7	242,30	0,00	1843	18000	YPM YPFM	83 / 80 M 4b	113 114	92 98
	4,3	209,47	0,91	1593	18000				
	5,8	242,30	1,23	1185	18000				
	6,7	209,47	1,38	1024	18000				
	6,9	201,75	1,48	986	18000				
	8,0	174,42	1,69	853	18000				
	9,0	156,13	1,90	763	18000				
	9,1	153,81	1,90	752	18000				
	10	137,68	2,10	673	18000				
	11	122,44	2,40	599	18000				
	13	109,64	2,60	536	18000				
	14	98,86	2,90	483	18000				
	16	89,02	3,30	435	18000				
	8,5	164,46	0,87	804	12750				
	9,6	145,66	0,96	712	12750				
	11	129,23	1,10	632	12750				
	13	111,72	1,27	546	12750				
	16	90,29	1,76	441	12750				
	18	76,73	2,10	375	12300				
	20	69,51	2,30	340	12300				
	22	63,22	2,50	309	12300	YPM YPFM	63 / 80 M 4b	103 104	38 40
	27	52,79	3,10	258	12300				
	31	44,51	3,60	218	12300				
	15	90,72	0,83	444	6700				
	17	82,51	0,94	403	6690				
20	68,90	1,10	337	6690					
21	65,14	1,17	318	6690					
22	63,66	1,20	311	6600					
24	58,09	1,30	284	6600					
27	52,64	1,43	257	6600	YPM YPFM				
29	47,69	1,63	233	6400					
32	43,37	1,78	212	6400					
39	36,22	2,12	177	6400					
46	30,54	2,47	149	6400					
44	31,54	2,60	157	6420					
56	24,78	3,20	123	6420					
61	23,10	3,50	115	6420	YPM YPFM	62 / 80 M 4b	103 104	34 36	
70	20,03	4,10	99	6420					
77	18,14	4,40	90	6420					





P <sub>1</sub> GÜÇ Power Puissance [kW] Hp	n <sub>2</sub> Çıkış Devri Output Speeds Vitesse de sortie [r.p.m]	İ Tahvil Ratio Rapport de réduction	S <sub>f</sub> Servis Faktörü Service Factor Service facteur	M <sub>2</sub> Çıkış Momenti Output Torque Couple de sortie [Nm]	F <sub>Q10</sub> Rad. Yük Over Loads Charges radiales [N]	Tip Type		 kg
0,75 1,1	29	48,45	0,84	237	4000	YPM YPFM 53 / 80 M 4b	99 100	25 27
	32	43,81	0,94	214	4000			
	35	39,46	1,01	193	4000			
	40	35,07	1,13	171	4000			
	45	31,33	1,27	153	4000			
	50	28,11	1,43	137	4000			
	55	25,30	1,57	124	4000			
	61	22,84	1,70	112	4000			
	54	25,75	1,57	128	3580	YPPM YPFPM 52 / 80 M 4b	99 100	23 25
	63	22,33	1,80	111	3580	YPM YPFM 52 / 80 M 4b	99 100	23 25
	72	19,56	2,10	97	3580			
	81	17,27	2,30	86	3580			
	91	15,35	2,60	76	3580			
	102	13,72	2,90	68	3180			
	114	12,31	3,30	61	3180			
	126	11,08	3,60	55	3180			
	140	10,00	3,97	50	3180			
	155	9,04	4,40	45	3180			
	163	8,59	4,53	43	2870			
	184	7,60	5,20	38	2870			
193	7,24	3,77	36	2870				
217	6,47	4,00	32	2870				
241	5,80	4,40	29	2870				
268	5,22	4,60	26	2870				
297	4,71	4,80	23	2870				
328	4,26	5,20	21	2870				
346	4,05	7,60	20	2870				
391	3,58	8,00	18	2870				
1,1 1,5	0,45	3094	0,88	21203	110000	YPM YPFM 153 İR 83 / 90 S 4a	149 150	869 909
	0,50	2815	0,97	19291	110000			
	0,60	2343	1,16	16057	110000			
	0,63	2222	1,23	15459	110000	YPM YPFM 152 İR 83 / 90 S 4a	149 150	859 599
	0,70	1988	1,36	13831	110000			
	0,78	1791	1,50	12461	110000			
	0,86	1624	1,70	11299	110000			
	0,95	1479	1,84	10290	110000			
	1,0	1353	2,00	9413	110000			
	1,1	1243	2,20	8648	110000	YPM YPFM 143 İR 73 / 90 S 4a	141 142	507 542
	0,58	2404	0,83	16475	75000			
	0,64	2177	0,91	14919	75000			
	0,58	2408	0,85	16754	75000	YPM YPFM 143 İR 72 / 90 S 4a	141 142	507 542
	0,72	1936	1,06	13470	75000			
	0,87	1617	1,27	11250	75000			
	0,98	1423	1,43	9900	75000	YPPM YPFPM 144 / 90 L 6b	139 140	536 571
	1,1	851	1,28	9350	75000			
	1,3	710,79	1,53	7810	75000			
	1,4	625,48	1,91	6872	75000			
	1,6	851	2,00	6011	75000			
	2,0	710,79	2,40	5021	75000			
	2,2	625,48	2,90	4418	75000	YPM YPFM 123 İR 72 / 90 S 4a	135 136	298 328
	0,86	1628	0,81	11327	61500			
	0,98	1428	0,90	9935	61500			
1,1	1290	1,00	8975	61500				
1,2	761,08	0,88	8362	61500				
1,3	687,35	0,97	7552	61500				
1,4	624,54	1,05	6862	61500	YPM YPFM 124 / 90 L 6b	133 134	295 325	
1,6	567,16	1,15	6232	61500				



P <sub>1</sub> GÜÇ Power Puissance [kW] Hp	n <sub>2</sub> Çıkış Devri Output Speeds Vitesse de sortie [r.p.m]	i Tahvil Ratio Rapport de réduction	S <sub>f</sub> Servis Faktörü Service Factor Service facteur	M <sub>2</sub> Çıkış Momenti Output Torque Couple de sortie [Nm]	F <sub>Q10</sub> Rad. Yük Over Loads Charges radiales [N]	Tip Type		 kg					
1,1	1,8	761,08	1,36	5376	61500	YPM YPFM	124 / 90 S 4a	133 134	294 324				
	2,0	687,35	1,50	4855	61500								
	2,2	624,54	1,64	4411	61500								
	2,5	567,16	1,84	4006	61500								
	2,7	512,21	2,05	3618	61500								
	3,0	465,40	2,25	3287	61500								
	3,3	425,05	2,39	3002	61500								
	3,6	389,91	2,70	2754	61500								
	4,1	342,17	3,00	2417	61500								
	4,5	309,02	3,30	2183	61500								
	2,0	708,53	0,84	5005	30500					YPM YPFM	104 / 90 S 4a	127 128	203 223
	2,2	629,29	0,94	4445	30500								
	2,5	563,83	1,04	3983	30500								
	2,8	508,84	1,18	3594	30500								
	3,0	462,00	1,28	3263	30500								
	3,6	392,00	1,51	2769	30500								
	4,0	350,76	1,65	2478	30500								
	4,8	293,55	2,00	2073	30500								
	5,4	258,69	2,25	1827	30500								
	6,1	229,90	2,52	1624	30500								
	6,8	205,71	2,86	1453	30500								
	3,3	270,11	1,36	3013	30500	YPPM YPFPM	103 / 90 L 6b	125 126	198 218				
	3,6	251,95	1,43	2810	30500								
	4,1	221,37	1,63	2469	30500								
	4,6	196,61	1,91	2193	30500								
	5,0	180,75	2,00	2016	30500								
	5,6	160,54	2,10	1791	30500	YPPM YPFPM	103 / 90 S 4a	125 126	196 216				
	5,2	270,11	2,10	1937	30500								
	5,6	251,95	2,30	1807	30500								
	6,3	221,37	2,60	1587	30500								
	7,1	196,61	3,00	1410	30500								
	7,7	180,75	3,10	1296	30000	YPM YPFM	92 İR 63 / 90 S 4a	123 124	128 131				
	8,7	160,54	3,40	1151	30000								
	2,2	628	0,81	4369	23000					YPM YPFM	94 / 90 S 4a	121 122	125 128
	2,5	570	0,87	3966	23000								
	2,7	519	0,95	3611	23000								
	3,0	470	1,00	3270	23000								
	3,2	433,91	0,80	3065	23000	YPM YPFM	93 / 90 L 6b	119 120	119 122				
	3,6	385,58	0,89	2723	23000								
	3,9	359,21	1,09	2537	23000								
	4,4	320,26	1,23	2262	23000								
	3,6	252,35	1,00	2815	23000					YPM YPFM	93 / 90 S 4a	119 120	117 120
3,8	235,39	1,08	2626	23000									
4,1	222,00	1,14	2476	23000									
4,2	213,04	1,20	2376	23000									
4,5	198,72	1,25	2217	23000									
4,9	285,83	1,36	2050	23000									
5,5	252,35	1,57	1810	23000									
5,9	235,39	1,63	1688	23000									
6,3	222,00	1,77	1592	23000									
6,6	213,04	1,84	1528	23000									
7,0	198,72	1,98	1425	23000									
7,8	179,17	2,20	1285	23000									
8,6	162,51	2,40	1165	23000									
9,7	144,37	2,70	1035	23000									
11	128,71	3,00	923	23000									





P <sub>1</sub> GÜÇ Power Puissance [kW] Hp	n <sub>2</sub> Çıkış Devri Output Speeds Vitesse de sortie [r.p.m]	i Tahvil Ratio Rapport de réduction	S <sub>f</sub> Servis Faktörü Service Factor Service facteur	M <sub>2</sub> Çıkış Momenti Output Torque Couple de sortie [Nm]	F <sub>Q10</sub> Rad. Yük Over Loads Charges radiales [N]	Tip Type		 kg					
1,1 1,5	6,7	209,47	0,91	1502	18000	YPM YPFM	83 / 90 S 4a	113 114	95 101				
	8,0	174,42	1,15	1251	18000								
	9,0	156,13	1,30	1120	18000								
	9,1	153,81	1,30	1103	18000								
	10	137,68	1,45	987	18000								
	11	122,44	1,65	878	18000								
	13	109,64	1,80	786	18000								
	14	98,86	2,00	709	18000								
	16	89,02	2,20	638	18000								
	19	75,07	2,80	538	17700								
	21	66,93	3,30	480	17550								
	23	60,09	3,50	431	17500								
	26	54,26	3,90	389	17500								
	29	48,22	4,50	346	17400								
	13	111,72	0,86	801	12300	YPM YPFM	73 / 90 S 4a	107 108	62 66				
	16	90,29	1,20	647	12300								
	18	76,73	1,45	550	12300								
	20	69,51	1,60	498	12300								
	22	63,22	1,75	453	12300								
	27	52,79	2,10	379	12000								
	28	50,03	2,20	359	12000								
	31	44,51	2,50	319	12000								
	33	42,51	2,60	305	12000								
	37	37,65	2,90	270	12000								
	42	33,42	3,30	240	12000								
	47	29,69	3,70	213	12000								
	42	32,94	3,50	240	12000					YPM YPFM	72 / 90 S 4a	107 108	59 63
	50	28,00	3,90	204	12000					YPM YPFM			
	21	65,14	0,80	467	6290	YPM YPFM	63 / 90 S 4a	103 104	42 44				
	22	63,66	0,82	456	6200								
	24	58,09	0,89	417	6200								
	27	52,64	0,98	378	6200								
	29	47,69	1,11	342	6000								
	32	43,37	1,21	311	5600								
	39	36,22	1,45	260	5550								
	46	30,54	1,68	219	5550								
	44	31,54	1,75	230	6000					YPPM YPPFM	62 / 90 S 4a	103 104	39 41
	61	23,10	2,40	168	6000					YPPM YPPFM			
	56	24,78	2,20	180	6000	YPM YPFM	62 / 90 S 4a	103 104	39 41				
	70	20,03	2,80	146	6000								
	77	18,14	3,00	132	5620								
	85	16,50	3,30	120	5620								
	95	14,67	3,70	107	5420								
	105	13,29	4,10	97	5420								
	116	12,09	4,50	88	5420	YPM YPFM	53 / 90 S 4a	99 100	29 31				
	45	31,33	0,86	225	4000								
50	28,11	0,98	202	4000									
55	25,30	1,07	181	4000									
61	22,84	1,16	164	4000	YPPM YPPFM	52 / 90 S 4a	99 100	27 29					
54	25,75	1,07	187	3490									
63	22,33	1,23	163	3750									
72	19,56	1,43	142	3750									
81	17,27	1,57	126	3490	YPM YPFM	52 / 90 S 4a	99 100	27 29					
91	15,35	1,77	112	3490									
102	13,72	1,98	100	3490									
114	12,31	2,25	90	3490									
126	11,08	2,45	81	3090	YPM YPFM	52 / 90 S 4a	99 100	27 29					
140	10,00	2,70	73	3090									





P <sub>1</sub> GÜÇ Power Puissance [kW] Hp	n <sub>2</sub> Çıkış Devri Output Speeds Vitesse de sortie [r.p.m]	İ Tahvil Ratio Rapport de réduction	S <sub>f</sub> Servis Faktörü Service Factor Service facteur	M <sub>2</sub> Çıkış Momenti Output Torque Couple de sortie [Nm]	F <sub>Q10</sub> Rad. Yük Over Loads Charges radiales [N]	Tip Type		 kg	
1,1 1,5	155	9,04	3,00	66	3090	YPM YPFM	52 / 90 S 4a	99 100	27 29
	163	8,59	3,09	63	3090				
	184	7,60	3,55	55	3090				
	193	7,24	2,57	53	2780				
	217	6,47	2,73	47	2780				
	241	5,80	3,00	42	2780				
	268	5,22	3,14	38	2780				
	297	4,71	3,27	34	2780				
	328	4,26	3,55	31	2780				
	346	4,05	5,18	29	2780				
	391	3,58	5,45	26	2780				
1,5 2,2	0,60	2343	0,85	21896	110000	YPM YPFM	153 İR 83 / 90 L 4a	149 150	872 912
	0,63	2222	0,90	21081	110000	YPM YPFM	152 İR 83 / 90 L 4a	149 150	862 902
	0,70	1988	1,00	18861	110000				
	0,78	1791	1,10	16992	110000				
	0,86	1624	1,25	15408	110000				
	0,95	1479	1,35	14032	110000				
	1,0	1353	1,50	12836	110000				
	1,1	1243	1,60	11793	110000				
	1,3	1057	1,90	10028	110000				
	1,5	584,89	2,10	8763	110000				
	1,7	528,04	2,40	7912	110000				
	2,0	455,48	2,70	6824	110000				
	2,3	389,89	3,20	5842	110000				
	2,6	347,80	3,50	5211	110000				
	2,9	311,14	4,00	4662	110000				
	0,72	1936	0,78	18368	75000				
	0,87	1617	0,94	15341	75000				
	0,98	1423	1,05	13501	75000				
	1,1	851	0,94	12750	75000				
	1,3	710,79	1,12	10650	75000				
	1,4	625,48	1,40	9371	75000				
	1,6	851,00	1,46	8197	75000				
	2,0	710,79	1,76	6846	75000				
	2,2	625,48	2,10	6025	75000				
	2,5	555,00	2,40	5346	75000				
	2,8	495,59	2,70	4773	75000				
	3,1	445,37	3,00	4290	75000				
	3,6	386,81	3,50	3726	75000				
	1,4	624,54	0,77	9357	61500				
	1,6	567,16	0,84	8498	61500				
	1,8	761,08	1,00	7331	61500				
	2,0	687,35	1,10	6620	61500				
	2,2	624,54	1,20	6015	61500				
2,5	567,16	1,35	5463	61500					
2,7	512,21	1,50	4934	61500					
3,0	465,40	1,65	4483	61500					
3,3	425,05	1,75	4094	61500					
3,6	389,91	1,98	3756	61500					
4,1	342,17	2,20	3296	61500					
4,5	309,02	2,42	2976	61500					
5,0	280,78	2,72	2704	61500					
5,5	256,44	2,94	2470	61500					
3,6	249,87	2,00	3801	61500					
4,1	219,68	2,30	3342	61500					
4,6	195,24	2,60	2970	61500					
5,1	175,05	2,80	2663	61500					
						YPM YPFM	124 / 100 L 6a	133 134	300 330
						YPM YPFM	124 / 90 L 4a	133 134	297 327
						YPM YPFM	123 / 100 L 6a	131 132	276 306



P <sub>1</sub> GÜÇ Power Puissance [kW] Hp	n <sub>2</sub> Çıkış Devri Output Speeds Vitesse de sortie [r.p.m]	i Tahvil Ratio Rapport de réduction	S <sub>f</sub> Servis Faktörü Service Factor Service facteur	M <sub>2</sub> Çıkış Momenti Output Torque Couple de sortie [Nm]	F <sub>Q10</sub> Rad. Yük Over Loads Charges radiales [N]	Tip Type		 kg
1,5 2,2	2,8	508,84	0,86	4901	29800	YPM YPFM	104 / 90 L 4a	127 206 128 226
	3,0	462,00	0,94	4450	29800			
	3,6	392,00	1,11	3776	29800			
	4,0	350,76	1,21	3378	29800			
	4,8	293,55	1,47	2827	29800			
	5,4	258,69	1,65	2492	29800			
	6,1	229,90	1,85	2214	29800			
	6,8	205,71	2,10	1981	29800			
	4,1	221,37	1,20	3367	29800	YPM YPFM	103 / 100 L 6a	125 203 126 223
	4,6	196,61	1,40	2991	29800			
	5,0	180,75	1,50	2749	29800			
	5,6	160,54	1,60	2442	29800	YPPM YPPFM	103 / 90 L 4a	125 198 126 218
	5,2	270,11	1,56	2641	29800			
	5,6	251,95	1,67	2464	29800			
	6,3	221,37	1,91	2165	29800			
	7,1	196,61	2,20	1923	29800			
	7,7	180,75	2,30	1767	29700			
	8,7	160,54	2,50	1570	29700			
	9,7	143,83	2,90	1406	29700	YPM YPFM	94 / 90 L 4a	121 128 122 131
	11	129,80	3,30	1269	29700			
	3,9	359,21	0,80	3460	23000	YPM YPFM	93 / 90 L 4a	119 119 120 122
	4,4	320,26	0,90	3085	23000			
	4,9	285,83	1,00	2795	23000			
	5,5	252,35	1,15	2468	23000			
	5,9	235,39	1,20	2302	23000			
	6,3	222,00	1,30	2171	23000			
	6,6	213,04	1,35	2083	23000			
	7,0	198,72	1,45	1943	23000			
	7,8	179,17	1,60	1752	23000			
	8,6	162,51	1,75	1589	23000			
	9,7	144,37	1,98	1412	23000			
	11	128,71	2,20	1259	23000			
	12	115,56	2,50	1130	23000			
	13	104,36	2,70	1020	23000			
	15	92,73	3,10	907	23000			
	9,0	156,13	0,95	1527	17800			
	9,1	153,81	0,95	1504	17750			
	10	137,68	1,06	1346	17700			
	11	122,44	1,21	1197	17550			
	13	109,64	1,32	1072	17400			
	14	98,86	1,46	967	17300			
	16	89,02	1,65	871	17300			
19	75,07	2,10	734	17150	YPM YPFM	73 / 90 L 4a	107 64 108 68	
21	66,93	2,40	654	17800				
23	60,09	2,60	588	17750				
26	54,26	2,90	531	17700				
29	48,22	3,30	472	17550				
33	42,58	3,70	416	17400				
41	33,81	4,60	331	17300				
16	90,29	0,88	883	12000				
18	76,73	1,06	750	12000				
20	69,51	1,17	680	12000				
22	63,22	1,28	618	12000				
27	52,79	1,54	516	12000				
28	50,03	1,61	489	12000				
31	44,51	1,80	435	12000				





P <sub>1</sub> GÜÇ Power Puissance [kW] Hp	n <sub>2</sub> Çıkış Devri Output Speeds Vitesse de sortie [r.p.m]	İ Tahvil Ratio Rapport de réduction	S <sub>f</sub> Servis Faktörü Service Factor Service facteur	M <sub>2</sub> Çıkış Momenti Output Torque Couple de sortie [Nm]	F <sub>Q10</sub> Rad. Yük Over Loads Charges radiales [N]	Tip Type		 kg	
1,5 2,2	33	42,51	1,90	416	11800	YPM YPFM	73 / 90 L 4a	107	64
	37	37,65	2,10	368	11800			108	68
	42	33,42	2,40	327	11800				
	47	29,69	2,70	290	11800	YPM YPFM	72 / 90 L 4a	107	61
	42	32,94	2,60	327	11500			108	65
	50	28,00	2,90	278	11500				
	57	24,69	3,30	245	11500	YPM YPFM	63 / 90 L 4a	103	44
	64	21,96	3,70	218	11500			104	46
	70	19,89	4,20	197	11500				
	29	47,69	0,81	466	5750	YPPM YPFPM	62 / 90 L 4a	103	41
	32	43,37	0,89	424	5550			104	43
	39	36,22	1,06	354	5550				
	46	30,54	1,23	299	5550	YPM YPFM	62 / 90 L 4a	103	41
	44	31,54	1,28	313	5560			104	43
	61	23,10	1,76	229	5370				
	56	24,78	1,61	246	5370	YPM YPFM	62 / 90 L 4a	103	41
	70	20,03	2,10	199	5370			104	43
	77	18,14	2,20	180	5370				
	85	16,50	2,40	164	5370	YPM YPFM	52 / 90 L 4a	99	29
	95	14,67	2,70	146	5370			100	31
	105	13,29	3,00	132	5250				
	116	12,09	3,30	120	5250	YPM YPFM	52 / 90 L 4a	99	29
	121	11,62	3,50	115	5250			100	31
	139	10,09	3,70	100	5250				
	152	9,21	4,20	91	5250	YPM YPFM	52 / 90 L 4a	99	29
	165	8,51	4,10	84	5200			100	31
	81	17,27	1,15	171	3400				
	91	15,35	1,30	152	3400	YPM YPFM	52 / 90 L 4a	99	29
	102	13,72	1,45	136	3400			100	31
	114	12,31	1,65	122	3400				
	126	11,08	1,80	110	3400	YPM YPFM	52 / 90 L 4a	99	29
	140	10,00	1,98	99	3000			100	31
	155	9,04	2,20	90	3000				
163	8,59	2,27	85	3000	YPM YPFM	52 / 90 L 4a	99	29	
184	7,60	2,60	75	3000			100	31	
193	7,24	1,88	72	3000					
217	6,47	2,00	64	2690	YPM YPFM	52 / 90 L 4a	99	29	
241	5,80	2,20	58	2690			100	31	
268	5,22	2,30	52	2690					
297	4,71	2,40	47	2690	YPM YPFM	52 / 90 L 4a	99	29	
328	4,26	2,60	42	2690			100	31	
346	4,05	3,80	40	2690					
391	3,58	4,00	36	2690	YPM YPFM	152 İR 83 / 100 L 4a	149	864	
0,86	1624	0,85	22598	110000			150	904	
0,95	1479	0,92	20580	110000					
1,0	1353	1,02	18827	110000	YPM YPFM	154 / 112 M 6a	147	898	
1,1	1243	1,09	17296	110000			148	938	
1,3	1057	1,30	14708	110000					
1,5	584,89	1,47	12853	110000	YPM YPFM	154 / 112 M 6a	147	898	
1,7	528,04	1,63	11604	110000			148	938	
2,0	455,48	1,89	10009	110000					
2,3	389,89	2,20	8568	110000	YPM YPFM	154 / 100 L 4a	147	840	
4,0	347,80	3,80	4913	110000			148	880	
4,5	311,14	0,00	4395	110000					
5,0	280,35	0,00	3960	110000	YPM YPFM	154 / 100 L 4a	147	840	
5,6	251,85	0,00	3558	110000			148	880	
6,0	232,41	0,00	3283	110000					



P <sub>1</sub> GÜÇ Power Puissance [kW] Hp	n <sub>2</sub> Çıkış Devri Output Speeds Vitesse de sortie [r.p.m]	İ Tahvil Ratio Rapport de réduction	S <sub>f</sub> Servis Faktörü Service Factor Service facteur	M <sub>2</sub> Çıkış Momenti Output Torque Couple de sortie [Nm]	F <sub>Q10</sub> Rad. Yük Over Loads Charges radiales [N]	Tip Type			kg
2,2 3	1,3	710,79	0,76	15620	75000	YPM YPFM	144 / 112 M 6a	139	597
	1,4	625,48	0,95	13745	75000			140	632
	1,6	851,00	1,00	12022	75000	YPM YPFM	144 / 100 L 4a	139 140	539 574
	2,0	710,79	1,20	10041	75000				
	2,2	625,48	1,45	8836	75000				
	2,5	555,00	1,65	7840	75000				
	2,8	495,59	1,85	7001	75000				
	3,1	445,37	2,00	6292	75000				
	3,6	386,81	2,40	5464	75000				
	4,1	340,38	2,70	4808	75000				
	4,6	302,03	3,00	4267	75000				
	2,2	624,54	0,82	8823	61500				
	2,5	567,16	0,92	8012	61500				
	2,7	512,21	1,02	7236	61500				
	3,0	465,40	1,13	6575	61500				
	3,3	425,05	1,19	6005	61500				
	3,6	389,91	1,35	5508	61500				
	4,1	342,17	1,50	4834	61500				
	4,5	309,02	1,65	4365	61500				
	5,0	280,78	1,85	3967	61500				
	5,5	256,44	2,00	3623	61500				
	3,6	249,87	1,36	5574	61500	YPM YPFM	123 / 112 M 6a	131 132	284 314
	4,1	219,68	1,55	4901	61500				
	4,6	195,24	1,74	4356	61500				
	5,1	175,05	1,94	3905	61500	YPM YPFM	123 / 100 L 4a	131 132	275 305
	5,6	249,87	2,10	3584	61500				
	6,4	219,68	2,40	3151	61500				
	7,2	195,24	2,70	2800	61500				
	8,0	175,05	3,00	2511	61500				
	8,9	158,09	3,30	2267	61500				
	9,7	143,64	3,70	2060	61500	YPM YPFM	104 / 100 L 4a	127 128	208 228
	4,0	350,76	0,83	4955	29000				
	4,8	293,55	1,00	4147	29000				
	5,4	258,69	1,13	3654	29000	YPM YPFM	103 / 112 M 6a	125 126	211 231
	4,6	196,61	0,95	4386	29000				
	5,0	180,75	1,02	4032	29000				
	5,6	160,54	1,10	3581	29000	YPPM YPPFPM	103 / 100 L 4a	125 126	202 222
	5,2	270,11	1,06	3874	29000				
	5,6	251,95	1,14	3613	29000	YPM YPFM	103 / 100 L 4a	125 126	202 222
	6,3	221,37	1,30	3175	29000				
	7,1	196,61	1,50	2820	28800				
	7,7	180,75	1,56	2592	28800				
8,7	160,54	1,70	2302	28800					
9,7	143,83	2,00	2063	28650					
11	129,80	2,20	1862	28600					
12	117,86	2,50	1690	28500					
14	100,00	2,90	1434	28500					
16	89,48	3,00	1283	28500					
7,0	198,72	0,99	2850	22000	YPM YPFM	93 / 100 L 4a	119 120	123 126	
7,8	179,17	1,09	2570	22000					
8,6	162,51	1,19	2331	22000					
9,7	144,37	1,35	2070	22000					
11	128,71	1,50	1846	22000					
12	115,56	1,70	1657	22000					
13	104,36	1,85	1497	22000					
15	92,73	2,20	1330	22000					
16	86,39	2,30	1239	22000					



P <sub>1</sub> GÜÇ Power Puissance [kW] Hp	n <sub>2</sub> Çıkış Devri Output Speeds Vitesse de sortie [r.p.m]	i Tahvil Ratio Rapport de réduction	S <sub>f</sub> Servis Faktörü Service Factor Service facteur	M <sub>2</sub> Çıkış Momenti Output Torque Couple de sortie [Nm]	F <sub>Q10</sub> Rad. Yük Over Loads Charges radiales [N]	Tip Type						
									kg			
2,2 3	18	77,02	2,60	1105	22000	YPM YPFM	93 / 100 L 4a	119	123			
	20	69,15	2,80	992	22000			120	126			
	22	62,45	3,20	896	22000	YPM YPFM	83 / 100 L 4a	113 114	101 107			
	13	109,64	0,90	1573	17170							
	14	98,86	1,00	1418	17070							
	16	89,02	1,12	1277	17070							
	19	75,07	1,43	1077	16920							
	21	66,93	1,64	960	16870							
	23	60,09	1,77	862	16770							
	26	54,26	1,98	778	16770							
	29	48,22	2,30	692	16770							
	33	42,58	2,50	611	16670							
	41	33,81	3,10	485	16570							
	46	30,34	3,50	435	16470							
	51	27,31	3,90	392	16370							
	54	25,84	3,40	376	16210							
	61	23,04	3,80	335	16150	YPM YPFM	82 / 100 L 4a	113 114	98 104			
	68	20,69	4,20	301	16000							
	75	18,68	4,80	272	16000	YPM YPFM	73 / 100 L 4a	107 108	68 72			
	20	69,51	0,80	997	11500							
	22	63,22	0,87	907	11500							
	27	52,79	1,05	757	11500							
	28	50,03	1,10	717	11500							
	31	44,51	1,22	638	11500							
	33	42,51	1,30	610	11500							
	37	37,65	1,48	540	11500							
	42	33,42	1,65	479	11500							
	47	29,69	1,85	426	11500							
	42	32,94	1,77	480	11500	YPM YPFM	72 / C90 L 4	107 108	61 65			
	50	28,00	1,98	408	11500							
	57	24,69	2,30	359	11300	YPM YPFM	72 / 100 L 4a	107 108	65 69			
	64	21,96	2,50	320	11300							
	70	19,89	2,80	290	11300							
	80	17,56	3,20	256	11300							
	90	15,61	3,60	227	11300							
	100	13,95	4,10	203	11300							
	46	30,54	0,84	438	5350	YPM YPFM	63 / 100 L 4a	103 104	48 50			
	44	31,54	0,87	459	4680							
	61	23,10	1,20	336	4680	YPFM	62 / 100 L 4a	103 104	45 47			
	56	24,78	1,10	361	4680	YPM YPFM	62 / C90 L 4	103 104	45 47			
70	20,03	1,40	292	4680								
77	18,14	1,50	264	4630	YPM YPFM	62 / 100 L 4a	103 104	45 47				
85	16,50	1,65	240	4580								
95	14,67	1,85	214	4530								
105	13,29	2,00	194	4530								
116	12,09	2,20	176	4530								
121	11,62	2,40	169	4530								
139	10,09	2,50	147	4430								
152	9,21	2,90	134	4430								
165	8,51	2,80	124	4430								
172	8,13	3,30	118	4250								
194	7,20	3,70	105	4250								
219	6,39	4,20	93	4250								
247	5,68	4,70	83	4250								
91	15,35	0,89	224	3500					YPM YPFM	52 / C90 L 4	99 100	29 31
193	7,24	1,28	105	3000								





P <sub>1</sub> GÜÇ Power Puissance [kW] Hp	n <sub>2</sub> Çıkış Devri Output Speeds Vitesse de sortie [r.p.m]	İ Tahvil Ratio Rapport de réduction	S <sub>f</sub> Servis Faktörü Service Factor Service facteur	M <sub>2</sub> Çıkış Momenti Output Torque Couple de sortie [Nm]	F <sub>Q10</sub> Rad. Yük Over Loads Charges radiales [N]	Tip Type		 kg	
2,2 3	102	13,72	0,99	200	3320	YPM YPFM	52 / 100 L 4a	99 100	33 35
	114	12,31	1,13	179	3320				
	126	11,08	1,23	161	3320				
	140	10,00	1,35	146	2920				
	155	9,04	1,50	132	2920				
	163	8,59	1,55	125	2920				
	184	7,60	1,77	111	2920				
	217	6,47	1,36	94	2920				
	241	5,80	1,50	84	2610				
	268	5,22	1,57	76	2610				
	297	4,71	1,64	69	2610				
	328	4,26	1,77	62	2610				
	346	4,05	2,59	59	2610				
	391	3,58	2,73	52	2610				
3 4	1,5	584,89	1,08	17527	110000	YPM YPFM	154 / 132 S 6b	147 148	867 907
	1,7	528,04	1,20	15823	110000				
	2,0	455,48	1,39	13649	110000				
	2,3	389,89	1,61	11683	110000				
	4,0	347,80	2,80	6700	110000				
	4,5	311,14	3,10	5994	110000				
	5,0	280,35	3,40	5401	110000				
	5,6	251,85	3,80	4852	110000				
	6,0	232,41	0,00	4477	110000				
	6,7	209,40	0,00	4034	110000				
	7,4	188,12	0,00	3624	110000				
	8,5	165,06	0,00	3180	110000				
	1,5	905	0,82	17172	75000				
	1,8	786	0,95	14914	75000				
	2,0	710,79	0,88	13692	75000				
	2,2	625,48	1,06	12049	75000				
	2,5	555,00	1,21	10691	75000				
	2,8	495,59	1,35	9547	75000				
	3,1	445,37	1,50	8580	75000				
	3,6	386,81	1,76	7451	75000				
	4,1	340,38	1,98	6557	75000				
	4,6	302,03	2,20	5818	75000				
	5,2	269,81	2,50	5198	75000				
	5,5	255,60	2,60	4924	75000				
	6,1	228,34	2,90	4399	75000				
	6,8	205,11	3,20	3951	75000				
	3,0	465,40	0,83	8965	61500				
	3,3	425,05	0,88	8188	61500				
	3,6	389,91	0,99	7511	61500				
	4,1	342,17	1,10	6591	61500				
	4,5	309,02	1,21	5953	61500				
	5,0	280,78	1,36	5409	61500				
	5,5	256,44	1,47	4940	61500				
	3,6	249,87	0,00	7601	61500				
4,1	219,68	0,00	6683	61500					
5,6	249,87	1,54	4887	61500					
6,4	219,68	1,76	4296	61500					
7,2	195,24	1,98	3818	61500					
8,0	175,05	2,20	3423	61500					
8,9	158,09	2,40	3092	61500					
9,7	143,64	2,70	2809	61500					
11	131,19	3,00	2566	61500					
12	120,34	3,20	2354	61500					
13	105,61	3,50	2065	61500					



P <sub>1</sub> GÜÇ Power Puissance [kW] Hp	n <sub>2</sub> Çıkış Devri Output Speeds Vitesse de sortie [r.p.m]	i Tahvil Ratio Rapport de réduction	S <sub>f</sub> Servis Faktörü Service Factor Service facteur	M <sub>2</sub> Çıkış Momenti Output Torque Couple de sortie [Nm]	F <sub>Q10</sub> Rad. Yük Over Loads Charges radiales [N]	Tip Type		 kg					
3 4	6,3	221,37	0,95	4329	28000	YPM YPFM	103 / 100 L 4b	125 126	205 225				
	7,1	196,61	1,10	3845	28000								
	7,7	180,75	1,15	3535	28000								
	8,7	160,54	1,25	3140	28000								
	9,7	143,83	1,47	2813	27500								
	11	129,80	1,65	2539	27500								
	12	117,86	1,84	2305	27500								
	14	100,00	2,10	1956	27500								
	16	89,48	2,20	1750	27500								
	19	74,89	2,70	1465	27500								
	21	65,99	3,10	1291	27200								
	24	58,65	3,50	1147	27200								
	9,7	144,37	0,99	2823	21000	YPM YPFM	93 / 100 L 4b	119 120	126 129				
	11	128,71	1,10	2517	21000								
	12	115,56	1,25	2260	21000								
	13	104,36	1,35	2041	21000								
	15	92,73	1,58	1814	21000								
	16	86,39	1,69	1690	21000								
	18	77,02	1,91	1506	21000								
	20	69,15	2,10	1352	20900								
	22	62,45	2,30	1221	20900								
	25	55,49	2,60	1085	20800								
	28	49,80	2,90	974	20800								
	31	44,90	3,20	878	20700								
	16	89,02	0,83	1741	16920	YPM YPFM	83 / 100 L 4b	113 114	104 110				
	19	75,07	1,05	1468	16920								
	21	66,93	1,20	1309	16870								
	23	60,09	1,30	1175	16770								
	26	54,26	1,45	1061	16770								
	29	48,22	1,65	943	16770								
	33	42,58	1,85	833	16920								
	41	33,81	2,30	661	16920								
	46	30,34	2,60	593	16870								
	51	27,31	2,90	534	16770								
	57	24,65	3,20	482	16770								
	63	22,29	3,50	436	16770								
	54	25,84	2,50	513	16000	YPM YPFM	82 / 100 L 4b	113 114	101 107				
	61	23,04	2,80	457	15800								
	68	20,69	3,10	411	15500								
	75	18,68	3,50	371	15300								
	84	16,60	3,90	330	15100								
	94	14,90	4,30	296	15000								
	104	13,43	4,80	267	15000								
	28	50,03	0,80	978	11300					YPM YPFM	73 / 100 L 4b	107 108	71 75
	31	44,51	0,90	870	11300								
	33	42,51	0,95	831	11300								
37	37,65	1,08	736	11300									
42	33,42	1,21	654	11300									
47	29,69	1,35	581	11300									
57	24,69	1,65	490	11000	YPM YPFM	72 / 100 L 4b	107 108	68 72					
64	21,96	1,85	436	11000									
70	19,89	2,10	395	11000									
80	17,56	2,30	349	11000									
90	15,61	2,60	310	11000									
100	13,95	3,00	277	11000									
112	12,51	3,30	248	11000									
124	11,26	3,60	224	11000									
138	10,17	4,00	202	11000									





P <sub>1</sub> GÜÇ Power Puissance [kW] Hp	n <sub>2</sub> Çıkış Devri Output Speeds Vitesse de sortie [r.p.m]	İ Tahvil Ratio Rapport de réduction	S <sub>f</sub> Servis Faktörü Service Factor Service facteur	M <sub>2</sub> Çıkış Momenti Output Torque Couple de sortie [Nm]	F <sub>Q10</sub> Rad. Yük Over Loads Charges radiales [N]	Tip Type		 kg			
<b>3</b> <b>4</b>	70	20,03	1,03	398	4780	YPM YPFM <b>62 / 100 L 4b</b>	103 104	48 50			
	77	18,14	1,10	360	4830						
	85	16,50	1,21	328	4730						
	95	14,67	1,35	291	4630						
	105	13,29	1,50	264	4630						
	116	12,09	1,65	240	4530						
	121	11,62	1,75	231	4530						
	139	10,09	1,85	200	4530						
	152	9,21	2,10	183	4530						
	165	8,51	2,00	169	4330						
	172	8,13	2,40	161	4330						
	194	7,20	2,70	143	4330						
	219	6,39	3,00	127	4330						
	247	5,68	3,40	113	4330						
	114	12,31	0,83	244	3320				YPM YPFM <b>52 / 100 L 4b</b>	99 100	36 38
	126	11,08	0,90	220	3320						
	140	10,00	0,99	198	2920						
	155	9,04	1,10	180	2920						
	163	8,59	1,13	171	2920						
	184	7,60	1,30	151	2920						
217	6,47	1,00	128	2810							
241	5,80	1,10	115	2810							
268	5,22	1,15	104	2810							
297	4,71	1,20	94	2810							
328	4,26	1,30	85	2810							
346	4,05	1,90	80	2810							
<b>4</b> <b>5,5</b>	1,5	908	0,83	22972	110000	YPM YPFM <b>152 İR 83 / 112 M 4b</b>	149 150	876 916			
	1,5	584,89	0,81	23369	110000						
	1,7	528,04	0,90	21098	110000	YPM YPFM <b>154 / 132 M 6a</b>	147 148	872 912			
	2,0	455,48	1,00	18198	110000						
	2,3	389,89	1,21	15578	110000	YPM YPFM <b>154 / 112 M 4b</b>	147 148	853 893			
	2,4	584,89	1,27	15023	110000						
	2,7	528,04	1,38	13563	110000						
	3,1	455,48	1,60	11699	110000						
	3,6	389,89	1,87	10014	110000						
	4,0	347,80	2,10	8933	110000						
	4,5	311,14	2,30	7992	110000						
	5,0	280,35	2,60	7201	110000						
	5,6	251,85	2,90	6469	110000						
	6,0	232,41	3,10	5969	110000						
	6,7	209,40	3,50	5378	110000	YPM YPFM <b>144 / 112 M 4b</b>	139 140	552 587			
	2,2	625,48	0,80	16065	75000						
	2,5	555,00	0,88	14255	75000						
	2,8	495,59	1,01	12729	75000						
	3,1	445,37	1,13	11439	75000						
	3,6	386,81	1,32	9935	75000						
4,1	340,38	1,48	8743	75000							
4,6	302,03	1,68	7758	75000							
5,2	269,81	1,87	6930	75000							
5,5	255,60	1,98	6565	75000							
6,1	228,34	2,20	5865	75000							
6,8	205,11	2,40	5268	75000	YPM YPFM <b>143 / 132 M 6a</b>	137 138	522 557				
4,5	198,33	1,50	8045	75000							
5,1	178,04	1,68	7222	75000							
5,6	161,00	1,86	6531	75000							
6,7	134,47	2,20	5455	75000							
7,6	118,33	2,80	4800	75000							



P <sub>1</sub> GÜÇ Power Puissance [kW] Hp	n <sub>2</sub> Çıkış Devri Output Speeds Vitesse de sortie [r.p.m]	i Tahvil Ratio Rapport de réduction	S <sub>f</sub> Servis Faktörü Service Factor Service facteur	M <sub>2</sub> Çıkış Momenti Output Torque Couple de sortie [Nm]	F <sub>Q10</sub> Rad. Yük Over Loads Charges radiales [N]	Tip Type			kg				
4 5,5	4,1	342,17	0,83	8789	61500	YPM YPFM	124 / 112 M 4b	133	311				
	4,5	309,02	0,91	7937	61500			134	341				
	5,0	280,78	1,02	7212	61500	YPM YPFM	123 / 112 M 4b	131 132	285 315				
	5,5	256,44	1,10	6587	61500								
	5,6	249,87	1,15	6516	61500								
	6,4	219,68	1,32	5728	61500								
	7,2	195,24	1,49	5091	61500								
	8,0	175,05	1,65	4565	61500								
	8,9	158,09	1,81	4122	61500								
	9,7	143,64	2,00	3746	61500								
	11	131,19	2,30	3421	61500								
	12	120,34	2,40	3138	61500								
	13	105,61	2,60	2754	61500								
	15	95,38	2,90	2487	61500								
	16	86,66	3,20	2260	61500								
	18	79,15	3,50	2064	61500								
	8,7	160,54	0,94	4186	27800	YPM YPFM	103 / 112 M 4b	125 126	212 232				
	9,7	143,83	1,10	3751	27800								
	11	129,80	1,24	3385	27800								
	12	117,86	1,38	3073	27700								
	14	100,00	1,62	2608	27700								
	16	89,48	1,68	2333	27600								
	19	74,89	2,00	1953	27800								
	21	65,99	2,30	1721	27800								
	24	58,65	2,70	1529	27800								
	27	52,48	2,90	1368	27700								
	30	47,22	3,30	1231	27700								
	33	42,69	3,70	1113	27600								
	12	115,56	0,94	3013	20800					YPM YPFM	93 / 112 M 4b	119 120	133 136
	13	104,36	1,02	2721	20800								
	15	92,73	1,18	2418	20800								
	16	86,39	1,26	2253	20800								
	18	77,02	1,43	2008	20800								
	20	69,15	1,54	1803	20650								
	22	62,45	1,76	1628	20650								
	25	55,49	1,92	1447	20500								
	28	49,80	2,10	1299	20500								
	31	44,90	2,40	1171	20400								
	34	40,62	2,60	1059	20400								
	38	36,87	2,90	961	20000								
	42	33,54	3,20	875	20000								
	44	31,96	3,00	846	19500	YPM YPFM	92 / 112 M 4b	119 120	130 133				
	49	28,84	3,30	763	19000								
	53	26,19	3,90	693	19000	YPM YPFM	83 / 112 M 4b	113 114	111 117				
21	66,93	0,90	1745	15750									
23	60,09	0,98	1567	15750									
26	54,26	1,09	1415	15700									
29	48,22	1,24	1257	15700									
33	42,58	1,39	1110	15700									
41	33,81	1,72	882	15600									
46	30,34	1,95	791	15600									
51	27,31	2,10	712	15600									
57	24,65	2,40	643	15600									
63	22,29	2,60	581	15600									
54	25,84	1,87	684	15200	YPM YPFM					82 / 112 M 4b	113 114	108 114	
61	23,04	2,10	610	15200									
68	20,69	2,30	548	15200									
75	18,68	2,60	495	14850									



P <sub>1</sub> GÜÇ Power Puissance [kW] Hp	n <sub>2</sub> Çıkış Devri Output Speeds Vitesse de sortie [r.p.m]	İ Tahvil Ratio Rapport de réduction	S <sub>f</sub> Servis Faktörü Service Factor Service facteur	M <sub>2</sub> Çıkış Momenti Output Torque Couple de sortie [Nm]	F <sub>Q10</sub> Rad. Yük Over Loads Charges radiales [N]	Tip Type		 kg	
4 5,5	84	16,60	2,90	439	14850	YPM YPFM	82 / 112 M 4b	113 114	108 114
	94	14,90	3,20	394	14800				
	104	13,43	3,60	356	14800				
	117	11,94	3,90	316	14550				
	121	11,57	3,90	306	14450				
	127	11,03	4,40	292	14450				
	134	10,45	4,20	277	14350				
	57	24,69	1,23	654	11000				
	64	21,96	1,39	581	11000	YPM YPFM	72 / 112 M 4b	107 108	75 79
	70	19,89	1,57	526	11000				
	80	17,56	1,76	465	11000				
	90	15,61	1,98	413	11000				
	100	13,95	2,20	369	11000				
	112	12,51	2,40	331	11000				
	124	11,26	2,70	298	11000				
	138	10,17	3,00	269	10850				
	152	9,19	3,40	243	10850				
	168	8,33	3,70	220	10850				
	179	7,83	3,20	207	10850				
	185	7,55	4,10	200	11000				
	200	7,00	3,40	185	11000	YPM YPFM	62 / 112 M 4b	103 104	48 50
	223	6,28	3,70	166	11000				
	248	5,65	3,90	150	11000				
	275	5,10	4,10	135	11000				
	304	4,61	4,30	122	11000				
	85	16,50	0,91	437	4280				
	95	14,67	1,01	388	4430				
	105	13,29	1,12	352	4330				
116	12,09	1,23	320	4330					
121	11,62	1,31	308	4230					
139	10,09	1,38	267	4230	YPM YPFM	154 / 132 M 6b	147 148	885 925	
152	9,21	1,60	244	4230					
165	8,51	1,54	225	4230					
172	8,13	1,81	215	4180					
194	7,20	2,00	191	4130					
219	6,39	2,30	169	4030					
247	5,68	2,60	150	4030					
5,5 7,5	2,3	389,89	0,88	21420					110000
	2,4	584,89	0,92	20657	110000				
	2,7	528,04	1,00	18649	110000	YPM YPFM	154 / 132 S 4c	147 148	864 904
	3,1	455,48	1,16	16086	110000				
	3,6	389,89	1,36	13770	110000				
	4,0	347,80	1,52	12283	110000				
	4,5	311,14	1,68	10989	110000				
	5,0	280,35	1,88	9901	110000				
	5,6	251,85	2,10	8895	110000				
	6,0	232,41	2,20	8208	110000				
	6,7	209,40	2,50	7395	110000				
	7,4	188,12	2,70	6644	110000				
	8,5	165,06	3,20	5829	110000	YPM YPFM	144 / 132 S 4c	139 140	563 598
	9,5	147,32	3,50	5203	110000				
	3,1	445,37	0,82	15729	75000				
	3,6	386,81	0,96	13661	75000				
	4,1	340,38	1,08	12021	75000				
	4,6	302,03	1,22	10667	75000				
5,2	269,81	1,36	9529	75000					



P <sub>1</sub> GÜÇ Power Puissance [kW] Hp	n <sub>2</sub> Çıkış Devri Output Speeds Vitesse de sortie [r.p.m]	İ Tahvil Ratio Rapport de réduction	S <sub>f</sub> Servis Faktörü Service Factor Service facteur	M <sub>2</sub> Çıkış Momenti Output Torque Couple de sortie [Nm]	F <sub>Q10</sub> Rad. Yük Over Loads Charges radiales [N]	Tip Type			kg										
5,5 7,5	5,5	255,60	1,14	9027	75000	YPM YPFM	144 / 132 S 4c	139	563										
	6,1	228,34	1,60	8064	75000			140	598										
	6,8	205,11	1,76	7244	75000	YPM YPFM	143 / 132 M 6b	137	522										
	4,5	198,33	1,09	11062	75000			138	557										
	5,1	178,04	1,22	9930	75000			YPM YPFM	143 / 132 S 4c	137	501								
	5,6	161,00	1,35	8980	75000					138	536								
	6,7	134,47	1,60	7500	75000	YPM YPFM	124 / 132 S 4c			133	322								
	7,6	118,33	2,00	6600	75000					134	352								
	7,1	198,33	1,70	7111	75000					YPM YPFM	123 / C112 M 4	131	286						
	7,9	178,04	1,91	6384	75000							132	316						
	8,7	161,00	2,10	5773	75000					YPM YPFM	123 / 132 S 4c	131	298						
	10	134,47	2,60	4821	75000			132	328										
	12	118,33	3,10	4243	75000	YPM YPFM	103 / C112 M 4	125	225										
	13	105,00	3,50	3765	75000			126	245										
	5,5	256,44	0,80	9057	61000			YPM YPFM	103 / 132 S 4c			125	225						
	6,4	219,68	0,96	7876	61000							126	245						
	7,2	195,24	1,08	7000	60900							YPM YPFM	93 / C112 M 4	119	134				
	8,0	175,05	1,20	6276	60900									120	137				
	8,9	158,09	1,32	5668	60900									YPM YPFM	93 / 132 S 4c	119	146		
	9,7	143,64	1,48	5150	60900											120	149		
	11	131,19	1,64	4704	60900											YPM YPFM	93 / 132 S 4c	119	146
	12	120,34	1,75	4315	60900													120	149
	13	105,61	1,91	3787	60500	YPM YPFM	93 / 132 S 4c											119	146
	15	95,38	2,10	3420	60500					120	149								
	16	86,66	2,30	3107	60500			YPM YPFM	93 / 132 S 4c	119	146								
	18	79,15	2,50	2838	60500					120	149								
	19	72,60	2,80	2603	60500					YPM YPFM	93 / 132 S 4c	119	146						
	22	64,73	3,20	2321	60500							120	149						
	24	57,16	3,60	2050	60500							YPM YPFM	93 / 132 S 4c	119	146				
	28	50,81	4,00	1822	60500									120	149				
	11	129,80	0,90	4654	27500									YPM YPFM	93 / 132 S 4c	119	146		
	12	117,86	1,00	4226	27500											120	149		
	14	100,00	1,18	3585	27400	YPM YPFM	93 / 132 S 4c									119	146		
	16	89,48	1,22	3208	27400											120	149		
	19	74,89	1,50	2685	27300			YPM YPFM	93 / 132 S 4c							119	146		
	21	65,99	1,70	2366	27200											120	149		
	24	58,65	1,95	2103	27100					YPM YPFM	93 / 132 S 4c					119	146		
	27	52,48	2,16	1882	26900											120	149		
	30	47,22	2,40	1693	26750							YPM YPFM	93 / 132 S 4c			119	146		
	33	42,69	2,70	1531	26600											120	149		
40	35,28	3,20	1265	26600	YPM YPFM									93 / 132 S 4c	119	146			
43	32,20	3,40	1155	26600											120	149			
49	28,84	0,00	1034	26500		YPM YPFM	93 / 132 S 4c								119	146			
16	86,39	0,92	3098	19400											120	149			
18	77,02	1,04	2762	19400				YPM YPFM	93 / 132 S 4c						119	146			
20	69,15	1,12	2479	19400											120	149			
22	62,45	1,28	2239	19400						YPM YPFM	93 / 132 S 4c				119	146			
25	55,49	1,40	1990	19300											120	149			
28	49,80	1,56	1786	19300								YPM YPFM	93 / 132 S 4c		119	146			
31	44,90	1,76	1610	19150											120	149			
34	40,62	1,92	1456	19150	YPM YPFM									93 / 132 S 4c	119	146			
38	36,87	2,10	1322	18750											120	149			
42	33,54	2,30	1203	18750		YPM YPFM	93 / 132 S 4c								119	146			
46	30,57	2,50	1096	18500											120	149			
50	27,91	2,80	1001	18500				YPM YPFM	93 / 132 S 4c						119	146			





P <sub>1</sub> GÜÇ Power Puissance [kW] Hp	n <sub>2</sub> Çıkış Devri Output Speeds Vitesse de sortie [r.p.m]	İ Tahvil Ratio Rapport de réduction	S <sub>f</sub> Servis Faktörü Service Factor Service facteur	M <sub>2</sub> Çıkış Momenti Output Torque Couple de sortie [Nm]	F <sub>Q10</sub> Rad. Yük Over Loads Charges radiales [N]	Tip Type		 kg	
5,5 7,5	44	31,96	2,20	1163	18500	YPM YPFM	92 / C112 M 4	119	131
	49	28,84	2,40	1050	18500	YPFM		120	134
	53	26,19	2,80	953	18500	YPM	92 / 132 S 4c	119	143
	64	21,90	3,10	797	18000	YPFM		120	146
	33	42,58	1,00	1527	15300	YPM YPFM	83 / 132 S 4c	113 114	124 130
	41	33,81	1,25	1212	15100				
	46	30,34	1,42	1088	15000				
	51	27,31	1,55	979	15000				
	57	24,65	1,75	884	15000				
	63	22,29	1,91	799	15000	YPM YPFM	82 / C112 M 4	113 114	121 127
	54	25,84	1,36	941	14950				
	61	23,04	1,52	839	14950	YPM YPFM	82 / 132 S 4c	113 114	121 127
	68	20,69	1,69	753	14950				
	75	18,68	1,91	680	14950				
	84	16,60	2,10	604	14950				
	94	14,90	2,30	542	14600				
	104	13,43	2,60	489	14600				
	117	11,94	2,90	434	14550				
	121	11,57	2,90	421	14550				
	127	11,03	3,20	401	14300				
	134	10,45	3,00	380	14200				
	140	10,03	3,70	365	14200				
	151	9,29	3,60	338	14100				
	168	8,33	3,60	303	14100				
	186	7,51	3,90	273	13800				
	210	6,67	4,00	243	13800				
	227	6,17	4,00	225	13600				
	249	5,61	4,20	204	13500				
	274	5,12	4,40	186	13500				
	300	4,67	4,60	170	13300				
	328	4,27	4,80	155	13000				
	57	24,69	0,90	899	10500	YPM YPFM	72 / C112 M 4	107 108	76 80
	64	21,96	1,00	799	10500				
	70	19,89	1,15	724	10500	YPM YPFM	72 / 132 S 4c	107 108	88 92
	80	17,56	1,28	639	10500				
	90	15,61	1,44	568	10500				
	100	13,95	1,64	508	10500				
112	12,51	1,80	455	10200					
124	11,26	2,00	410	10200					
138	10,17	2,20	370	10200					
152	9,19	2,50	335	10200					
168	8,33	2,70	303	10200					
179	7,83	2,30	285	10000					
185	7,55	3,00	275	10000					
200	7,00	2,50	255	10000					
223	6,28	2,70	228	10000					
248	5,65	2,80	206	10000					
275	5,10	3,00	186	10000					
304	4,61	3,10	168	10000					
335	4,18	3,30	152	10000					
370	3,79	3,40	138	10000					
7,5 11	3,1	455,48	0,85	21935	110000	YPM YPFM	154 / 132 M 4b	147 148	871 911
	3,6	389,89	1,00	18777	110000				
	4,0	347,80	1,11	16750	110000				
	4,5	311,14	1,23	14984	110000				
	5,0	280,35	1,38	13501	110000				
	5,6	251,85	1,52	12129	110000				



P <sub>1</sub> GÜÇ Power Puissance [kW] Hp	n <sub>2</sub> Çıkış Devri Output Speeds Vitesse de sortie [r.p.m]	i Tahvil Ratio Rapport de réduction	S <sub>f</sub> Servis Faktörü Service Factor Service facteur	M <sub>2</sub> Çıkış Momenti Output Torque Couple de sortie [Nm]	F <sub>Q10</sub> Rad. Yük Over Loads Charges radiales [N]	Tip Type		 kg	
7,5 11	6,0	232,41	1,64	11192	110000	YPM YPFM	154 / 132 M 4b	147 148	871 911
	6,7	209,40	1,84	10085	110000				
	7,4	188,12	2,00	9060	110000				
	8,5	165,06	2,30	7949	110000				
	9,5	147,32	2,60	7095	110000				
	3,5	259,58	0,94	19742	110000	YPM YPFM	153 / 160 M 6b	145 146	836 876
	3,9	233,55	1,05	17762	110000				
	4,3	210,26	1,20	15991	110000				
	4,7	190,57	1,32	14494	110000				
	5,4	167,80	1,50	12762	110000				
	6,0	150,40	1,67	11439	110000				
	6,6	135,78	1,85	10327	110000				
	7,7	117,12	2,10	8908	110000				
	9,0	100,26	2,40	7625	110000				
	10	89,43	2,70	6802	110000				
	11	80,01	3,10	6085	110000	YPM YPFM	144 / 132 M 4b	139 140	570 605
	12	72,09	3,40	5483	110000				
	14	64,76	3,80	4926	110000				
	4,1	340,38	0,79	16393	75000				
	4,6	302,03	0,90	14546	75000				
	5,2	269,81	1,00	12994	75000	YPM YPFM	143 / 160 M 6b	137 138	533 568
	5,5	255,60	1,05	12310	75000				
	6,1	228,34	1,17	10996	75000				
	6,8	205,11	1,29	9878	75000				
	5,1	178,04	0,90	13541	75000	YPM YPFM	143 / 132 M 4b	137 138	508 543
	5,6	161,00	0,99	12245	75000				
	6,7	134,47	1,17	10227	75000				
	7,6	118,33	1,49	9000	75000				
	7,1	198,33	1,25	9697	75000				
	7,9	178,04	1,40	8705	75000	YPM YPFM	123 / 132 M 4b	131 132	309 339
	8,7	161,00	1,54	7872	75000				
	10	134,47	1,93	6575	75000				
	12	118,33	2,30	5786	75000				
	13	105,00	2,60	5134	75000				
	15	93,80	2,90	4586	75000	YPM YPFM	123 / 132 M 4b	131 132	309 339
	17	84,26	3,20	4120	75000				
	19	73,18	3,70	3578	75000				
	8,0	175,05	0,88	8559	60000				
	8,9	158,09	0,97	7729	60000				
	9,7	143,64	1,08	7023	59000				
	11	131,19	1,20	6414	59000				
	12	120,34	1,28	5884	58000				
	13	105,61	1,40	5163	57500				
	15	95,38	1,56	4663	57000				
	16	86,66	1,72	4237	57000	YPM YPFM	103 / 132 M 4b	125 126	236 256
18	79,15	1,87	3870	57000					
19	72,60	2,10	3550	55000					
22	64,73	2,30	3165	55000					
24	57,16	2,60	2795	55000					
28	50,81	2,90	2484	55000	YPM YPFM	103 / 132 M 4b	125 126	236 256	
31	45,39	3,40	2219	55000					
34	40,73	3,70	1991	55000					
16	89,48	0,90	4375	27000					
19	74,89	1,10	3661	27000					
21	65,99	1,25	3227	26900	YPM YPFM	103 / 132 M 4b	125 126	236 256	
24	58,65	1,43	2867	26900					
27	52,48	1,58	2566	26750					



P <sub>1</sub> GÜÇ Power Puissance [kW] Hp	n <sub>2</sub> Çıkış Devri Output Speeds Vitesse de sortie [r.p.m]	i Tahvil Ratio Rapport de réduction	S <sub>f</sub> Servis Faktörü Service Factor Service facteur	M <sub>2</sub> Çıkış Momenti Output Torque Couple de sortie [Nm]	F <sub>Q10</sub> Rad. Yük Over Loads Charges radiales [N]	Tip Type		 kg	
7,5	30	47,22	1,76	2309	26650	YPM YPFM	103 / 132 M 4b	125 126	236 256
	33	42,69	1,98	2087	26550				
	40	35,28	2,30	1725	26400				
	43	32,20	2,50	1575	27000				
	49	28,84	2,80	1410	27000				
	58	24,18	3,40	1182	26900				
	69	20,39	4,00	997	26900	YPM YPFM	102 / 132 M 4b	125 126	231 251
	53	26,38	3,20	1309	26000				
	58	24,31	3,60	1207	26000	YPM YPFM	93 / 132 M 4b	119 120	157 160
	25	55,49	1,03	2713	18800				
	28	49,80	1,14	2435	18800				
	31	44,90	1,29	2195	18650				
	34	40,62	1,41	1986	18650				
	38	36,87	1,55	1802	18250				
	42	33,54	1,70	1640	18250				
	46	30,57	1,88	1495	18000				
	50	27,91	2,10	1365	18000	YPM YPFM	92 / 132 M 4b	119 120	154 157
	53	26,19	2,10	1300	18000				
	64	21,90	2,30	1087	18500				
	66	21,34	2,80	1059	18500				
	74	18,81	3,10	934	18000	YPM YPFM	83 / 132 M 4b	113 114	135 141
	84	16,72	3,40	830	18000				
	94	14,96	3,80	742	17700				
	41	33,81	0,92	1653	14900				
	46	30,34	1,04	1483	14800	YPM YPFM	82 / 132 M 4b	113 114	132 138
	51	27,31	1,14	1335	14800				
	57	24,65	1,28	1205	14800				
	63	22,29	1,40	1090	14800				
	68	20,69	1,24	1027	14800				
	75	18,68	1,40	927	14450				
	84	16,60	1,56	824	14450				
	94	14,90	1,72	739	14400				
	104	13,43	1,92	667	14400				
	117	11,94	2,10	592	14400				
	121	11,57	2,10	574	14050				
	127	11,03	2,30	547	14050				
	134	10,45	2,20	519	13950				
	140	10,03	2,70	498	13950				
	151	9,29	2,70	461	13650				
	168	8,33	2,70	414	13650				
186	7,51	2,90	373	13450					
210	6,67	2,90	331	13350					
227	6,17	2,90	306	13350					
249	5,61	3,10	279	13150					
274	5,12	3,20	254	12850					
300	4,67	3,40	232	12600					
328	4,27	3,50	212	12350					
80	17,56	0,94	872	10000	YPM YPFM	72 / 132 M 4b	107 108	99 103	
90	15,61	1,05	775	10000					
100	13,95	1,20	692	10000					
112	12,51	1,32	621	10000					
124	11,26	1,46	559	10000					
138	10,17	1,60	505	10000					
152	9,19	1,81	456	9700					
168	8,33	1,97	413	9700					
179	7,83	1,70	389	9700					



P <sub>1</sub> GÜÇ Power Puissance [kW] Hp	n <sub>2</sub> Çıkış Devri Output Speeds Vitesse de sortie [r.p.m]	i Tahvil Ratio Rapport de réduction	S <sub>f</sub> Servis Faktörü Service Factor Service facteur	M <sub>2</sub> Çıkış Momenti Output Torque Couple de sortie [Nm]	F <sub>Q10</sub> Rad. Yük Over Loads Charges radiales [N]	Tip Type		 kg			
7,5 11	185	7,55	2,20	375	10000	YPM YPFM 72 / 132 M 4b	107 108	99 103			
	200	7,00	1,81	347	10000						
	223	6,28	1,97	312	10000						
	248	5,65	2,10	280	10000						
	275	5,10	2,20	253	10000						
	304	4,61	2,30	229	10000						
	335	4,18	2,40	207	9700						
	370	3,79	2,50	188	9700						
11 15	4,1	341,55	0,81	23763	110000	YPM YPFM 153 İR 92 / 160 M 4b	151 152	955 995			
	4,5	309,97	0,89	21566	110000						
	5,0	282,01	0,98	19621	110000						
	6,0	234,68	1,18	16328	110000						
	7,1	196,15	1,41	13647	110000	YPM YPFM 153 / 160 L 6b	145 146	863 903			
	4,7	190,57	0,90	21258	110000						
	5,4	167,80	1,02	18718	110000	YPM YPFM 153 / 160 M 4b	145 146	846 886			
	6,0	150,40	1,13	16777	110000						
	5,4	259,58	1,00	18614	110000						
	6,0	233,55	1,11	16747	110000						
	6,7	210,26	1,27	15077	110000						
	7,3	190,57	1,40	13666	110000						
	8,3	167,80	1,59	12033	110000						
	9,3	150,40	1,77	10785	110000						
	10	135,78	1,96	9737	110000						
	12	117,12	2,20	8399	110000						
	14	100,26	2,60	7189	110000						
	16	89,43	2,90	6413	110000						
	17	80,01	3,20	5737	110000						
	19	72,09	3,60	5169	110000						
	6,2	225,00	0,89	15654	75000				YPM YPFM 143 İR 82 / 160 M 4b	143 144	650 685
	6,9	204,00	0,95	14193	75000						
	9,0	156,00	1,25	10854	75000						
	9,9	142,00	1,35	9880	75000						
	6,7	134,47	0,80	15000	75000	YPM YPFM 143 / 160 L 6b	137 138	620 655			
	7,6	118,33	1,02	13200	75000						
	7,9	178,04	0,95	12767	75000	YPM YPFM 143 / 160 M 4b	137 138	545 580			
	8,7	161,00	1,05	11545	75000						
	10	134,47	1,32	9643	75000						
	12	118,33	1,57	8486	75000						
	13	105,00	1,77	7529	75000						
	15	93,80	1,98	6726	75000						
	17	84,26	2,20	6042	75000						
	19	73,18	2,50	5248	75000						
	22	64,40	2,80	4618	75000						
	25	57,14	3,20	4097	75000						
	13	105,61	0,95	7573	57140	YPM YPFM 123 / 160 M 4b	131 132	363 393			
	15	95,38	1,06	6839	56640						
	16	86,66	1,17	6214	56640						
	18	79,15	1,27	5676	56640						
19	72,60	1,42	5206	54640							
22	64,73	1,58	4642	54640							
24	57,16	1,79	4099	54640							
28	50,81	2,00	3643	54640							
31	45,39	2,30	3255	54640							
34	40,73	2,50	2920	57140							
38	36,66	2,80	2629	56640							





P <sub>1</sub> GÜÇ Power Puissance [kW] Hp	n <sub>2</sub> Çıkış Devri Output Speeds Vitesse de sortie [r.p.m]	i Tahvil Ratio Rapport de réduction	S <sub>f</sub> Servis Faktörü Service Factor Service facteur	M <sub>2</sub> Çıkış Momenti Output Torque Couple de sortie [Nm]	F <sub>Q10</sub> Rad. Yük Over Loads Charges radiales [N]	Tip Type			kg
11 15	42	33,09	3,10	2373	56640	YPM YPFM	123 / 160 M 4b	131	363
	47	29,92	3,40	2146	56640			132	393
	52	27,10	3,80	1943	54640	YPM YPFM	122 / 160 M 4b	131	358
	57	24,57	0,00	1762	54640			132	388
	47	29,50	3,30	2148	54300	YPM YPFM	103 / 160 M 4b	125 126	258 278
	52	26,68	3,90	1942	54300				
	24	58,65	0,97	4206	26000				
	27	52,48	1,08	3763	25750				
	30	47,22	1,20	3386	25650				
	33	42,69	1,35	3061	25300				
	40	35,28	1,60	2530	25100				
	43	32,20	1,74	2309	25000				
	49	28,84	1,94	2068	24900				
	58	24,18	2,30	1734	24600				
	69	20,39	2,70	1462	24300				
	53	26,38	2,20	1920	24300				
	58	24,31	2,40	1770	24300				
	67	20,78	2,80	1513	24100				
	76	18,48	3,20	1345	24000				
	85	16,55	3,60	1205	23800	YPM YPFM	93 / 160 M 4b	119 120	211 214
	94	14,90	4,00	1085	23600				
	34	40,62	0,96	2913	17450				
	38	36,87	1,06	2644	17450				
	42	33,54	1,16	2405	17000	YPM YPFM	92 / C132 M 4	119 120	208 211
	46	30,57	1,28	2192	17000				
	50	27,91	1,40	2001	17000	YPM YPFM	92 / 160 M 4b	119 120	208 211
	53	26,19	1,40	1906	17200				
	64	21,90	1,55	1595	17200	YPM YPFM	82 / C132 M 4	113 114	134 140
	66	21,34	1,91	1554	16700				
	74	18,81	2,10	1369	16700	YPM YPFM	82 / 160 M 4b	113 114	134 140
	84	16,72	2,30	1217	16300				
	94	14,96	2,60	1089	16300	YPM YPFM	82 / 160 M 4b	113 114	134 140
	104	13,46	2,90	980	16200				
	115	12,17	3,20	886	16200				
	68	20,69	0,85	1506	14500				
	75	18,68	0,95	1360	14501				
	121	11,57	1,45	842	14502				
	134	10,45	1,52	761	14100				
	84	16,60	1,06	1209	14500				
	94	14,90	1,17	1085	14100				
	104	13,43	1,30	978	14100				
	117	11,94	1,45	869	14000				
127	11,03	1,60	803	13770					
140	10,03	1,85	730	13770					
151	9,29	1,82	676	13600					
168	8,33	1,82	607	13600					
186	7,51	1,96	547	13300					
210	6,67	2,00	485	13300					
227	6,17	2,00	449	13100					
249	5,61	2,10	409	13000					
274	5,12	2,20	372	13000					
300	4,67	2,30	340	12800					
328	4,27	2,40	311	12500					
112	12,51	0,90	911	9500	YPM YPFM	72 / C132 M 4	107 108	101 105	
124	11,26	1,00	820	9500					
138	10,17	1,09	740	9500					
152	9,19	1,23	669	9500					
168	8,33	1,35	606	9350					



P <sub>1</sub> GÜÇ Power Puissance [kW] Hp	n <sub>2</sub> Çıkış Devri Output Speeds Vitesse de sortie [r.p.m]	i Tahvil Ratio Rapport de réduction	S <sub>f</sub> Servis Faktörü Service Factor Service facteur	M <sub>2</sub> Çıkış Momenti Output Torque Couple de sortie [Nm]	F <sub>Q10</sub> Rad. Yük Over Loads Charges radiales [N]	Tip Type		 kg	
11 15	179	7,83	1,16	570	9350	YPM YPFM	72 / C132 M 4	107 108	101 105
	185	7,55	1,49	550	9350				
	200	7,00	1,24	509	9350				
	223	6,28	1,35	457	9350				
	248	5,65	1,42	411	9000				
	275	5,10	1,49	371	9000				
	304	4,61	1,56	336	9000				
	335	4,18	1,64	304	9000				
	370	3,79	1,70	276	9000				
15 20	6,0	234,68	0,86	22265	110000	YPM YPFM	153 İR 92 / 160 L 4a	151 152	975 1015
	7,1	196,15	1,03	18610	110000				
	6,0	233,55	0,81	22837	110000	YPM YPFM	153 / 160 L 4a	145 146	866 906
	6,7	210,26	0,93	20560	110000				
	7,3	190,57	1,02	18635	110000				
	8,3	167,80	1,16	16409	110000				
	9,3	150,40	1,30	14707	110000				
	10	135,78	1,43	13278	110000				
	12	117,12	1,61	11453	110000				
	14	100,26	1,90	9804	110000				
	16	89,43	2,10	8745	110000				
	17	80,01	2,30	7824	110000				
	19	72,09	2,60	7049	110000				
	22	64,76	2,90	6333	110000				
	25	56,82	3,40	5556	110000				
	9,0	156	0,92	14800	75000				
	9,9	142	0,99	13472	75000				
	10	134,47	0,97	13150	75000	YPM YPFM	143 / 160 L 4a	137 138	565 600
	12	118,33	1,15	11571	75000				
	13	105,00	1,30	10267	75000				
	15	93,80	1,45	9172	75000				
	17	84,26	1,61	8239	75000				
	19	73,18	1,83	7156	75000				
	22	64,40	2,00	6297	75000				
	25	57,14	2,30	5587	75000				
	27	51,05	2,60	4991	75000				
	29	48,36	2,70	4729	75000				
	32	43,20	3,10	4224	75000				
	18	79,15	0,93	7739	55670	YPM YPFM	123 / 160 L 4a	131 132	395 425
	19	72,60	1,04	7100	53670				
	22	64,73	1,16	6330	53670				
	24	57,16	1,31	5590	53670				
	28	50,81	1,47	4968	53670				
	31	45,39	1,69	4439	53670				
	34	40,73	1,83	3982	53670				
	38	36,66	2,00	3585	53380				
42	33,09	2,30	3236	53380					
47	29,92	2,50	2926	53380					
52	27,10	2,80	2650	53330	YPM YPFM	122 / 160 L 4a	131 132	390 420	
57	24,57	3,00	2402	53000					
47	29,50	2,40	2929	53380					
52	26,68	2,90	2649	53330					
63	22,28	3,40	2212	53000	YPM YPFM	103 / 160 L 4a	125 126	273 293	
71	19,61	3,70	1947	53000					
33	42,69	0,99	4175	23100					
40	35,28	1,17	3449	22850					
43	32,20	1,27	3149	22500					
49	28,84	1,42	2820	21950					
58	24,18	1,70	2365	21650					
69	20,39	2,00	1994	21300					





P <sub>1</sub> GÜÇ Power Puissance [kW] Hp	n <sub>2</sub> Çıkış Devri Output Speeds Vitesse de sortie [r.p.m]	i Tahvil Ratio Rapport de réduction	S <sub>f</sub> Servis Faktörü Service Factor Service facteur	M <sub>2</sub> Çıkış Momenti Output Torque Couple de sortie [Nm]	F <sub>Q10</sub> Rad. Yük Over Loads Charges radiales [N]	Tip Type		 kg
15 20	53	26,38	1,62	2619	22450	YPM YPFM 102 / 160 L 4a	125 126	268 288
	58	24,31	1,80	2413	22100			
	67	20,78	2,10	2063	21800			
	76	18,48	2,30	1834	21650			
	85	16,55	2,60	1643	21250			
	94	14,90	2,90	1479	20800			
	104	13,48	3,20	1338	20550			
	114	12,25	3,50	1216	20350			
	125	11,16	3,80	1108	20000			
	137	10,20	3,80	1013	19800			
	150	9,32	3,90	925	19600			
	166	8,41	3,90	835	19450			
	53	26,19	1,03	2600	13600	YPPM YPFPM 92 / 160 L 4a	119 120	240 243
	64	21,90	1,14	2174	13600			
	66	21,34	1,40	2119	13100			
	74	18,81	1,55	1867	13100			
	84	16,72	1,70	1659	12700	YPM YPFM 92 / 160 L 4a	119 120	240 243
	94	14,96	1,90	1485	12700			
	104	13,46	2,20	1336	12650			
	115	12,17	2,40	1208	12650			
	127	11,04	2,60	1096	12600			
	139	10,05	2,80	998	12600			
	153	9,18	3,10	911	12300			
	167	8,40	3,10	834	11550			
	182	7,70	3,20	764	11400			
	216	6,49	3,30	644	11150			
	235	5,97	3,40	592	11000			
	255	5,49	3,50	545	11000			
	340	4,12	3,80	409	10500	YPM YPFM 82 / 160 L 4a	113 114	134 140
	94	14,90	0,85	1479	14500			
	104	13,43	0,95	1333	14100			
	117	11,94	1,06	1185	14100			
127	11,03	1,17	1095	14000				
140	10,03	1,36	996	13770				
151	9,29	1,33	922	13770				
168	8,33	1,33	827	13600				
186	7,51	1,43	746	13600				
210	6,67	1,46	662	13300				
227	6,17	1,46	612	13300				
249	5,61	1,54	557	13100				
274	5,12	1,61	508	13000				
300	4,67	1,68	464	13000				
328	4,27	1,76	424	12800	YPM YPFM 153 / 180 M 4b	145 146	906 946	
7,3	190,57	0,83	22983	110000				
8,3	167,80	0,94	20238	110000				
9,3	150,40	1,05	18139	110000				
10	135,78	1,16	16376	110000				
12	117,12	1,30	14125	110000				
14	100,26	1,55	12091	110000				
16	89,43	1,72	10786	110000				
17	80,01	1,90	9649	110000				
19	72,09	2,10	8694	110000				
22	64,76	2,40	7810	110000				
25	56,82	2,70	6853	110000				
28	50,72	3,10	6117	110000				
31	45,52	3,40	5489	110000				



P <sub>1</sub> GÜÇ Power Puissance [kW] Hp	n <sub>2</sub> Çıkış Devri Output Speeds Vitesse de sortie [r.p.m]	i Tahvil Ratio Rapport de réduction	S <sub>f</sub> Servis Faktörü Service Factor Service facteur	M <sub>2</sub> Çıkış Momenti Output Torque Couple de sortie [Nm]	F <sub>Q10</sub> Rad. Yük Over Loads Charges radiales [N]	Tip Type		 kg	
18,5	13	105,00	1,05	12663	75000	YPM YPFM	143 / 180 M 4b	137 138	605 640
	15	93,80	1,18	11313	75000				
	17	84,26	1,31	10162	75000				
	19	73,18	1,48	8826	75000				
	22	64,40	1,66	7766	75000				
	25	57,14	1,90	6891	75000				
	27	51,05	2,10	6156	75000				
	29	48,36	2,20	5832	75000				
	32	43,20	2,50	5210	75000				
	36	38,80	2,80	4680	75000				
	40	35,02	3,10	4223	75000				
	22	64,73	0,94	7807	52000	YPM YPFM	123 / 180 M 4b	131 132	415 445
	24	57,16	1,06	6894	52000				
	28	50,81	1,20	6128	51500				
	31	45,39	1,37	5475	51500				
	34	40,73	1,49	4912	51200				
	38	36,66	1,66	4421	51090				
	42	33,09	1,86	3990	51000				
	47	29,92	2,00	3609	50500				
	52	27,10	2,30	3269	50500				
	57	24,57	2,40	2963	50000				
	47	29,50	1,96	3612	50000	YPPM YPPFM	122 / 180 M 4b	131 132	400 430
	52	26,68	2,30	3267	50000	YPM YPFM	122 / 180 M 4b	131 132	410 440
	63	22,28	2,70	2728	49000				
	71	19,61	3,00	2401	48500				
	80	17,40	3,30	2130	48000				
	90	15,54	3,70	1903	47000				
	100	13,96	4,00	1709	47000	YPM YPFM	103 / 180 M 4b	125 126	295 315
	58	24,18	1,38	2917	20300				
	69	20,39	1,62	2460	20000	YPPM YPPFM	102 / 180 M 4b	125 126	290 310
	53	26,38	1,31	3230	20300	YPM YPFM	102 / 180 M 4b	125 126	290 310
	58	24,31	1,46	2977	20000				
	67	20,78	1,72	2544	19750				
	76	18,48	1,92	2262	19600				
	85	16,55	2,10	2026	19500				
	94	14,90	2,30	1824	19400				
	104	13,48	2,60	1651	19300				
	114	12,25	2,80	1500	19150				
	125	11,16	3,00	1367	19000				
	137	10,20	3,00	1249	19000				
150	9,32	3,20	1141	18850					
166	8,41	3,20	1030	18700					
184	7,61	3,30	932	20000					
203	6,89	3,20	844	19750					
224	6,25	3,50	765	19600					
245	5,72	3,70	701	19500					
270	5,18	4,00	635	19400					
74	18,81	1,26	2303	11300	YPPM YPPFM	92 / 180 M 4b	119 120	260 263	
84	16,72	1,38	2047	10900					
94	14,96	1,54	1831	10900	YPM YPFM	92 / 180 M 4b	119 120	260 263	
104	13,46	1,74	1648	10800					
115	12,17	1,91	1490	10800					
127	11,04	2,10	1352	10700					
139	10,05	2,30	1231	10700					
153	9,18	2,50	1124	10500					





P <sub>1</sub> GÜÇ Power Puissance [kW] Hp	n <sub>2</sub> Çıkış Devri Output Speeds Vitesse de sortie [r.p.m]	i Tahvil Ratio Rapport de réduction	S <sub>f</sub> Servis Faktörü Service Factor Service facteur	M <sub>2</sub> Çıkış Momenti Output Torque Couple de sortie [Nm]	F <sub>Q10</sub> Rad. Yük Over Loads Charges radiales [N]	Tip Type		 kg	
18,5 25	167	8,40	2,50	1028	10000	YPM YPFM	92 / 180 M 4b	119 120	260 263
	182	7,70	2,60	942	9600				
	216	6,49	2,70	795	9600				
	235	5,97	2,80	731	9250				
	255	5,49	2,80	672	9250				
	340	4,12	3,10	504	9000				
22 30	8,3	167,80	0,80	24066	110000	YPM YPFM	153 / 180 L 4a	145 146	921 961
	9,3	150,40	0,88	21570	110000				
	10	135,78	0,98	19474	110000				
	12	117,12	1,10	16798	110000				
	14	100,26	1,30	14379	110000				
	16	89,43	1,45	12827	110000				
	17	80,01	1,60	11475	110000				
	19	72,09	1,80	10339	110000				
	22	64,76	2,00	9288	110000				
	25	56,82	2,30	8149	110000				
	28	50,72	2,60	7274	110000				
	31	45,52	2,80	6528	110000				
	34	41,03	3,20	5885	110000				
	38	37,13	3,50	5324	110000				
	42	33,69	3,90	4832	110000				
	15	93,80	0,99	13453	75000	YPM YPFM	143 / 180 L 4a	137 138	620 655
	17	84,26	1,10	12084	75000				
	19	73,18	1,25	10495	75000				
	22	64,40	1,40	9236	75000				
	25	57,14	1,60	8195	75000				
	27	51,05	1,80	7321	75000				
	29	48,36	1,85	6935	75000				
	32	43,20	2,10	6195	75000				
	36	38,80	2,40	5565	75000				
	40	35,02	2,60	5022	75000				
	44	31,72	2,80	4549	75000				
	49	28,82	3,10	4133	75000				
	52	27,09	2,60	3944	75000	YPM YPFM	142 / 180 L 4a	137 138	612 647
	58	24,16	2,90	3518	75000				
	64	21,71	3,20	3161	75000	YPM YPFM	123 / 180 L 4b	131 132	440 470
	24	57,16	0,90	8198	50330				
	28	50,81	1,00	7287	49830				
	31	45,39	1,15	6510	49830				
	34	40,73	1,25	5841	49530				
	38	36,66	1,40	5258	49420				
	42	33,09	1,57	4745	49330				
47	29,92	1,70	4292	48830					
52	27,10	1,90	3887	48830					
57	24,57	2,00	3524	48330					
52	26,68	1,95	3885	48030					
63	22,28	2,30	3245	47030					
71	19,61	2,60	2855	46530					
80	17,40	2,80	2533	46030					
90	15,54	3,10	2263	45030					
100	13,96	3,40	2033	45030					
111	12,60	4,00	1835	44000					
123	11,41	4,40	1662	43200					
135	10,37	4,90	1510	43000					
58	24,31	1,23	3540	18800	YPM YPFM	102 / 180 L 4b	125 126	304 324	
67	20,78	1,45	3025	18600					
76	18,48	1,62	2690	18400					
85	16,55	1,81	2409	18150					





P <sub>1</sub> GÜÇ Power Puissance [kW] Hp	n <sub>2</sub> Çıkış Devri Output Speeds Vitesse de sortie [r.p.m]	i Tahvil Ratio Rapport de réduction	S <sub>f</sub> Servis Faktörü Service Factor Service facteur	M <sub>2</sub> Çıkış Momenti Output Torque Couple de sortie [Nm]	F <sub>Q10</sub> Rad. Yük Over Loads Charges radiales [N]	Tip Type		 kg	
22 30	94	14,90	2,00	2170	18000	YPM YPFM	102 / 180 L 4b	125 126	304 324
	104	13,48	2,20	1963	17900				
	114	12,25	2,40	1783	17750				
	125	11,16	2,60	1625	17450				
	137	10,20	2,60	1485	17200				
	150	9,32	2,70	1357	17000				
	166	8,41	2,70	1225	16850				
	184	7,61	2,80	1108	16600				
	203	6,89	2,70	1003	16400				
	224	6,25	3,00	910	16150				
	245	5,72	3,10	833	16000				
	270	5,18	3,40	755	16000				
	298	4,70	3,80	684	16000				
	94	14,96	1,30	2178	9700	YPM YPFM	92 / 180 L 4b	119 120	285 288
	104	13,46	1,47	1960	9600				
	115	12,17	1,60	1772	9600				
	127	11,04	1,77	1608	9500				
	139	10,05	1,91	1464	9500				
	153	9,18	2,10	1336	9300				
	167	8,40	2,10	1223	8800				
182	7,70	2,20	1121	8400					
216	6,49	2,30	945	8400					
235	5,97	2,30	869	8200					
255	5,49	2,40	799	8050					
340	4,12	2,60	599	8000					
30 40	12	117,12	0,80	22906	110000	YPM YPFM	153 / 200 L 4c	145 146	936 976
	14	100,26	0,95	19607	110000				
	16	89,43	1,06	17491	110000				
	17	80,01	1,17	15647	110000				
	19	72,09	1,32	14099	110000				
	22	64,76	1,46	12666	110000				
	25	56,82	1,70	11113	110000				
	28	50,72	1,90	9919	110000				
	31	45,52	2,10	8901	110000				
	34	41,03	2,30	8024	110000				
	38	37,13	2,60	7261	110000				
	42	33,69	2,90	6589	110000				
	46	30,65	3,10	5995	110000				
	55	25,51	3,70	4989	110000				
	22	64,40	1,03	12594	75000	YPM YPFM	143 / 200 L 4c	137 138	635 670
	25	57,14	1,17	11175	75000				
	27	51,05	1,32	9983	75000				
	29	48,36	1,35	9457	75000				
	32	43,20	1,54	8448	75000				
	36	38,80	1,72	7589	75000				
	40	35,02	1,90	6848	75000				
	44	31,72	2,10	6203	75000				
	49	28,82	2,30	5636	75000				
	53	26,25	2,50	5134	75000				
	60	23,20	2,70	4538	75000				
	67	21,02	3,00	4110	75000				
	52	27,09	1,91	5378	75000				
58	24,16	2,10	4798	75000					
64	21,71	2,40	4310	75000					
74	19,05	2,70	3782	75000					
82	17,00	2,90	3375	75000					
87	16,12	3,10	3200	75000					



P <sub>1</sub> GÜÇ Power Puissance [kW] Hp	n <sub>2</sub> Çıkış Devri Output Speeds Vitesse de sortie [r.p.m]	i Tahvil Ratio Rapport de réduction	S <sub>f</sub> Servis Faktörü Service Factor Service facteur	M <sub>2</sub> Çıkış Momenti Output Torque Couple de sortie [Nm]	F <sub>Q10</sub> Rad. Yük Over Loads Charges radiales [N]	Tip Type		 kg	
30 40	34	40,73	0,92	7965	47530	YPM YPFM	123 / 200 L 4c	131 132	495 525
	38	36,66	1,03	7170	47420				
	42	33,09	1,15	6471	47330				
	47	29,92	1,25	5852	46830				
	52	27,10	1,40	5300	46830				
	57	24,57	1,50	4805	46330				
	71	19,61	1,87	3893	45960	YPM YPFM	122 / 200 L 4c	131 132	490 520
	80	17,40	2,10	3455	45460				
	90	15,54	2,30	3086	44460				
	100	13,96	2,50	2772	44460				
	111	12,60	2,90	2502	43430				
	123	11,41	3,20	2266	42630				
	135	10,37	3,60	2059	42430				
	148	9,45	3,90	1875	42400				
	162	8,62	4,20	1712	42000				
	169	8,27	4,20	1642	42000				
	188	7,46	4,70	1481	42000				
	207	6,76	5,10	1342	41300				
	228	6,14	5,10	1219	41100				
	250	5,59	5,10	1110	40500				
	274	5,11	5,10	1014	40500				
	300	4,67	5,20	927	40000				
	328	4,27	5,20	848	40000				
	358	3,91	5,20	777	40000				
	94	14,90	1,46	2959	15800	YPM YPFM	102 / 200 L 4c	125 126	336 356
	104	13,48	1,61	2677	15700				
	114	12,25	1,76	2432	15450				
	125	11,16	1,90	2216	15250				
	137	10,20	1,90	2025	15000				
	150	9,32	1,98	1851	14750				
166	8,41	1,98	1671	14600					
184	7,61	2,00	1511	14400					
203	6,89	2,00	1368	14100					
224	6,25	2,20	1240	13700					
245	5,72	2,30	1136	13550					
270	5,18	2,50	1029	13400					
298	4,70	2,80	933	13200					
37 50	17	80,01	0,95	19298	110000	YPM YPFM	153 / 225 S 4a	145 146	1075 1115
	19	72,09	1,07	17388	110000				
	22	64,76	1,19	15621	110000				
	25	56,82	1,37	13706	110000				
	28	50,72	1,54	12233	110000				
	31	45,52	1,70	10978	110000				
	34	41,03	1,90	9897	110000				
	38	37,13	2,10	8955	110000				
	42	33,69	2,30	8127	110000				
	46	30,65	2,50	7394	110000				
	55	25,51	3,00	6153	110000				
	66	21,32	3,60	5143	110000				
	22	64,40	0,83	15533	75000	YPM YPFM	143 / 225 S 4a	137 138	774 809
	25	57,14	0,95	13782	75000				
	27	51,05	1,07	12312	75000				
	29	48,36	1,10	11664	75000				
32	43,20	1,25	10420	75000					
36	38,80	1,40	9360	75000					



P <sub>1</sub> GÜÇ Power Puissance [kW] Hp	n <sub>2</sub> Çıkış Devri Output Speeds Vitesse de sortie [r.p.m]	i Tahvil Ratio Rapport de réduction	S <sub>f</sub> Servis Faktörü Service Factor Service facteur	M <sub>2</sub> Çıkış Momenti Output Torque Couple de sortie [Nm]	F <sub>Q10</sub> Rad. Yük Over Loads Charges radiales [N]	Tip Type		 kg					
37 50	40	35,02	1,55	8446	75000	YPM YPFM	143 / 225 S 4a	137 138	774 809				
	44	31,72	1,69	7650	75000								
	49	28,82	1,87	6951	75000								
	53	26,25	2,00	6332	75000								
	60	23,20	2,20	5597	75000								
	67	21,02	2,40	5069	75000								
	52	27,09	1,55	6633	75000	YPM YPFM	142 / 225 S 4a	137 138	766 801				
	58	24,16	1,74	5917	75000								
	64	21,71	1,93	5316	75000								
	74	19,05	2,20	4664	75000								
	82	17,00	2,40	4163	75000								
	87	16,12	2,50	3947	75000								
	97	14,39	3,10	3523	75000								
	108	12,91	3,50	3162	75000								
	71	19,61	1,52	4802	37070					YPM YPFM	122 / 225 S 4a	131 132	525 555
	80	17,40	1,66	4261	37070								
	90	15,54	1,84	3806	37070								
	100	13,96	2,00	3419	35570								
	111	12,60	2,40	3085	35570								
	123	11,41	2,60	2795	35570								
	135	10,37	2,90	2539	35570								
	148	9,45	3,20	2313	34070								
	162	8,62	3,40	2111	34070								
	169	8,27	3,40	2025	34070								
	188	7,46	3,80	1827	34070								
	207	6,76	4,10	1655	34070								
	228	6,14	4,10	1504	32570								
	250	5,59	4,10	1370	32570								
274	5,11	4,10	1250	32570									
300	4,67	4,20	1143	32570									
328	4,27	4,20	1046	32570									
358	3,91	4,20	958	32570									
45 60	22	64,76	0,98	18998	110000	YPM YPFM	153 / 225 M 4c	145 146	1091 1131				
	25	56,82	1,13	16669	110000								
	28	50,72	1,26	14878	110000								
	31	45,52	1,40	13352	110000								
	34	41,03	1,56	12037	110000								
	38	37,13	1,72	10891	110000								
	42	33,69	1,90	9884	110000								
	46	30,65	2,10	8992	110000								
	55	25,51	2,50	7483	110000								
	66	21,32	3,00	6255	110000								
	50	28,27	2,30	8419	110000					YPM YPFM	152 / 225 M 4c	145 146	1081 1121
	58	24,20	2,50	7207	110000								
	65	21,65	2,90	6448	110000								
	72	19,51	3,10	5809	110000								
	29	48,36	0,90	14186	75000	YPM YPFM	143 / 225 M 4c	137 138	790 825				
	32	43,20	1,03	12672	75000								
	36	38,80	1,15	11383	75000								
	40	35,02	1,27	10272	75000								
	44	31,72	1,39	9304	75000								
	49	28,82	1,54	8454	75000								
	53	26,25	1,68	7701	75000								
	60	23,20	1,83	6807	75000								
	67	21,02	2,00	6165	75000								
	52	27,09	1,04	8067	75000					YPM YPFM	142 / 225 M 4c	137 138	782 817
	58	24,16	1,43	7196	75000								
	64	21,71	1,59	6465	75000								







P <sub>1</sub> GÜÇ Power Puissance [kW] Hp	n <sub>2</sub> Çıkış Devri Output Speeds Vitesse de sortie [r.p.m]	i Tahvil Ratio Rapport de réduction	S <sub>f</sub> Servis Faktörü Service Factor Service facteur	M <sub>2</sub> Çıkış Momenti Output Torque Couple de sortie [Nm]	F <sub>Q10</sub> Rad. Yük Over Loads Charges radiales [N]	Tip Type		 kg	
45 60	74	19,05	1,80	5672	75000	YPM YPFM	142 / 225 M 4c	137 138	782 817
	82	17,00	1,97	5063	75000				
	87	16,12	2,10	4800	75000				
	97	14,39	2,50	4285	75000				
	108	12,91	2,80	3845	75000				
	120	11,64	3,10	3466	75000				
	133	10,53	3,40	3136	75000				
	146	9,56	3,50	2846	75000				
	161	8,70	3,80	2590	75000				
	182	7,71	4,00	2297	75000				
	201	6,98	4,10	2078	75000				
	221	6,33	4,10	1886	75000				
	71	19,61	1,25	5840	34500				
	80	17,40	1,37	5182	34500				
	90	15,54	1,52	4629	34500				
	100	13,96	1,66	4158	33000				
	111	12,60	1,96	3753	33000				
	123	11,41	2,20	3399	33000				
	135	10,37	2,40	3088	33000				
	148	9,45	2,60	2813	31500				
	162	8,62	2,80	2568	31500				
	169	8,27	2,80	2462	31500				
	188	7,46	3,10	2222	31500				
	207	6,76	3,40	2013	31500				
	228	6,14	3,40	1829	30000				
	250	5,59	3,40	1666	30000				
	274	5,11	3,40	1520	30000				
	300	4,67	3,50	1390	30000				
328	4,27	3,50	1272	30000					
358	3,91	3,50	1166	30000					
55 75	25	56,82	0,93	20374	110000	YPM YPFM	153 / 250 M 4c	145 146	1181 1221
	28	50,72	1,03	18184	110000				
	31	45,52	1,14	16319	110000				
	34	41,03	1,27	14712	110000				
	38	37,13	1,41	13311	110000				
	42	33,69	1,56	12081	110000				
	46	30,65	1,68	10991	110000				
	55	25,51	2,00	9146	110000				
	66	21,32	2,40	7645	110000				
	50	28,27	1,88	10290	110000				
	58	24,20	2,10	8809	110000				
	65	21,65	2,40	7880	110000				
	72	19,51	2,60	7100	110000				
	79	17,68	2,90	6436	110000				
	87	16,11	3,20	5863	110000				
	95	14,74	3,50	5364	110000				
	40	35,02	1,04	12555	75000				
	44	31,72	1,14	11372	75000				
	49	28,82	1,26	10333	75000				
	53	26,25	1,38	9412	75000				
	60	23,20	1,50	8319	75000				
	67	21,02	1,66	7536	75000				
	58	24,16	1,17	8796	75000				
	64	21,71	1,30	7902	75000				
	74	19,05	1,48	6933	75000				
	82	17,00	1,61	6188	75000				
	87	16,12	1,68	5867	75000				
						YPM YPFM	142 / 250 M 4c	137 138	872 907





P <sub>1</sub> GÜÇ Power Puissance [kW] Hp	n <sub>2</sub> Çıkış Devri Output Speeds Vitesse de sortie [r.p.m]	i Tahvil Ratio Rapport de réduction	S <sub>f</sub> Servis Faktörü Service Factor Service facteur	M <sub>2</sub> Çıkış Momenti Output Torque Couple de sortie [Nm]	F <sub>Q10</sub> Rad. Yük Over Loads Charges radiales [N]	Tip Type		 kg					
55 75	97	14,39	2,10	5237	75000	YPM YPFM	142 / 250 M 4c	137 138	872 907				
	108	12,91	2,30	4700	75000								
	120	11,64	2,50	4237	75000								
	133	10,53	2,80	3833	75000								
	146	9,56	2,90	3479	75000								
	161	8,70	3,10	3165	75000								
	182	7,71	3,30	2807	75000								
	201	6,98	3,30	2540	75000								
	221	6,33	3,30	2305	75000								
	243	5,76	3,40	2097	75000								
	292	4,80	3,40	1745	75000								
	349	4,01	3,60	1459	75000								
75 100	31	45,52	0,84	22254	110000	YPM YPFM	153 / 280 S 4	145 146	1311 1351				
	34	41,03	0,94	20061	110000								
	38	37,13	1,04	18151	110000								
	42	33,69	1,14	16473	110000								
	46	30,65	1,23	14987	110000								
	55	25,51	1,50	12472	110000								
	66	21,32	1,79	10424	110000								
	79	17,68	2,10	8776	110000								
	YPM YPFM	87	16,11	2,30	7996	110000	152 / 280 S 4	145 146	1301 1341				
		95	14,74	2,50	7315	110000							
		103	13,53	2,80	6717	110000							
		122	11,52	3,30	5716	110000							
		142	9,89	3,80	4910	110000							
		49	28,82	0,92	14090	75000				YPM YPFM	143 / 280 S 4	137 138	1010 1045
		53	26,25	1,01	12834	75000							
		60	23,20	1,10	11345	75000							
	67	21,02	1,22	10276	75000								
	YPM YPFM	64	21,71	0,95	10775	75000	142 / 280 S 4	137 138	1002 1037				
		74	19,05	1,08	9454	75000							
		82	17,00	1,18	8438	75000							
		87	16,12	1,23	8001	75000							
		97	14,39	1,53	7141	75000							
		108	12,91	1,73	6409	75000							
		120	11,64	1,87	5777	75000							
		133	10,53	2,10	5227	75000							
		146	9,56	2,10	4744	75000							
		161	8,70	2,30	4316	75000							
		182	7,71	2,40	3828	75000							
201		6,98	2,50	3464	75000								
221	6,33	2,50	3144	75000									
243	5,76	2,50	2860	75000									
292	4,80	2,50	2380	75000									
349	4,01	2,60	1989	75000									
90 120	42	33,69	0,95	19768	110000	YPM YPFM	153 / 280 M 4	145 146	1376 1416				
	46	30,65	1,02	17985	110000								
	55	25,51	1,25	14966	110000								
	66	21,32	1,49	12509	110000								
	YPM YPFM	79	17,68	1,77	10532	110000	152 / 280 M 4	145 146	1366 1406				
		87	16,11	1,95	9595	110000							
		95	14,74	2,10	8778	110000							
		103	13,53	2,30	8061	110000							
		122	11,52	2,70	6859	110000							
		142	9,89	3,10	5892	110000							
	YPM YPFM	60	23,20	0,92	13614	75000	143 / 280 M 4	137 138	1075 1110				
		67	21,02	1,01	12331	75000							





P <sub>1</sub> GÜÇ Power Puissance [kW] Hp	n <sub>2</sub> Çıkış Devri Output Speeds Vitesse de sortie [r.p.m]	i Tahvil Ratio Rapport de réduction	S <sub>f</sub> Servis Faktörü Service Factor Service facteur	M <sub>2</sub> Çıkış Momenti Output Torque Couple de sortie [Nm]	F <sub>Q10</sub> Rad. Yük Over Loads Charges radiales [N]	Tip Type		 kg	
90 120	74	19,05	0,90	11345	75000	YPM YPFM	142 / 280 M 4	137 138	1067 1102
	82	17,00	0,98	10126	75000				
	87	16,12	1,03	9601	75000				
	97	14,39	1,27	8569	75000				
	108	12,91	1,44	7690	75000				
	120	11,64	1,56	6933	75000				
	133	10,53	1,73	6273	75000				
	146	9,56	1,77	5693	75000				
	161	8,70	1,90	5179	75000				
	182	7,71	2,00	4594	75000				
	201	6,98	2,10	4156	75000				
	221	6,33	2,10	3772	75000				
	243	5,76	2,10	3432	75000				
	292	4,80	2,10	2856	75000				
349	4,01	2,20	2387	75000					
110 150	46	30,65	0,84	21981	110000	YPM YPFM	153 / 315 S 4	145 146	1545 1585
	55	25,51	1,02	18292	110000				
	66	21,32	1,22	15289	110000				
	79	17,68	1,45	12872	110000				
	87	16,11	1,60	11727	110000				
	95	14,74	1,75	10729	110000				
	103	13,53	1,90	9852	110000				
	122	11,52	2,20	8383	110000				
142	9,89	2,60	7201	110000					
132 180	79	17,68	1,20	15446	110000	YPM YPFM	152 / 315 M 4a	145 146	1612 1652
	87	16,11	1,33	14072	110000				
	95	14,74	1,45	12875	110000				
	103	13,53	1,58	11823	110000				
	122	11,52	1,84	10060	110000				
142	9,89	2,10	8641	110000					
160 220	87	16,11	1,10	17057	110000	YPM YPFM	152 / 315 M 4b	145 146	1633 1673
	95	14,74	1,20	15605	110000				
	103	13,53	1,30	14331	110000				
	122	11,52	1,51	12194	110000				
	142	9,89	1,78	10474	110000				
185 250	103	13,53	1,13	16570	110000	YPM YPFM	152 / 315 L 4a	145 146	1713 1753
	122	11,52	1,31	14099	110000				
	142	9,89	1,55	12110	110000				
200 270	122	11,52	1,21	15242	110000	YPM YPFM	152 / 315 L 4b	145 146	1766 1806
	142	9,89	1,43	13092	110000				





Servis Faktörü Service Factor Service facteur	S <sub>f</sub> = 1 S <sub>f</sub> = 1 S <sub>f</sub> = 1	P <sub>1</sub>	n <sub>2</sub>	i	M <sub>2</sub>	F <sub>Q1</sub>	F <sub>Q10</sub>	Tip Type		
		GÜÇ Power Puissance [kW]	Çıkış Devri Output Speeds Vitesse de sortie [r.p.m] (n <sub>1</sub> =1400rpm)	Tahvil Ratio Rapport de réduction	Çıkış Momenti Output Torque Couple de sortie [Nm]	Rad. Yük Over Loads Charges radiales [N]	Rad. Yük Over Loads Charges radiales [N]			
200 Nm	0,00	0,19	7251	200	390	4500	YP YPF	53 İR 43	101 102	28 29
	0,01	0,22	6352	200	390	4500				
	0,01	0,24	5772	200	390	4500				
	0,01	0,27	5097	200	390	4500				
	0,01	0,31	4530	200	390	4500				
	0,01	0,35	4048	200	390	4500				
	0,01	0,39	3631	200	390	4500				
	0,01	0,43	3269	200	390	4500				
	0,01	0,47	2950	200	390	4500				
	0,01	0,52	2668	200	390	4500				
	0,01	0,58	2403	200	390	4500				
	0,02	0,66	2136	200	390	4500				
	0,02	0,73	1908	200	390	4500				
	0,02	0,82	1712	200	390	4500				
	0,02	0,91	1541	200	390	4500				
	0,02	1,0	1391	200	390	4500				
	0,02	1,0	1360	200	390	4500				
	0,03	1,2	1191	200	390	4500				
	0,03	1,3	1052	200	390	4500				
	0,03	1,5	934	200	390	4500				
	0,04	1,7	835	200	390	4500				
	0,04	1,9	749	200	390	4500				
	0,05	2,1	675	200	390	4500				
	0,05	2,3	609	200	390	4500				
	0,06	2,5	551	200	390	4500				
	0,06	2,7	523	200	390	4500				
	0,07	3,0	463	200	390	4500				
	0,08	3,6	394	200	390	4500				
	0,10	4,4	318	200	390	4500				
	0,02	1,0	1339	200	390	4500				
	0,03	1,2	1173	200	390	4500				
	0,03	1,3	1066	200	390	4500				
	0,03	1,5	941	200	390	4500				
	0,04	1,7	836	200	390	4500				
	0,04	1,9	747	200	390	4500				
	0,05	2,1	654	200	390	4500				
	0,05	2,4	587	200	390	4500				
	0,06	2,7	517	200	390	4500				
	0,08	3,3	420	200	390	4500				
	0,08	3,7	380	200	390	4500				
	0,09	4,0	352	200	390	4500				
	0,10	4,4	316	200	390	4500				
	0,11	4,9	284	200	390	4500				
	0,12	5,4	257	200	390	4500				
	0,13	5,6	249	200	390	4500				
0,14	6,2	225	200	390	4500					
0,16	7,1	198	200	390	4500					
0,18	8,2	171	200	390	4500					
0,21	9,1	154	200	390	4500					
0,23	10	137	200	390	4500					
0,26	11	123	200	390	4500					
0,29	13	110	200	390	4500					
0,32	14	98,0	200	390	4500					
0,22	10	137,31	200	475	4500					
0,26	12	119,07	200	475	4500					
0,29	13	104,31	200	475	4500					
0,32	15	94,78	200	475	4500					
							YP YPF	53	99 100	18 20





Servis Faktörü Service Factor Service facteur	S <sub>r</sub> =1 S <sub>f</sub> =1 S <sub>f</sub> =1	P <sub>1</sub>	n <sub>2</sub>	i	M <sub>2</sub>	F <sub>Q1</sub>	F <sub>Q10</sub>	Tip Type				
		GÜÇ Power Puissance [kW]	Çıkış Devri Output Speeds Vitesse de sortie [r.p.m] (n <sub>1</sub> =1400rpm)	Tahvil Ratio Rapport de réduction	Çıkış Momenti Output Torque Couple de sortie [Nm]	Rad. Yük Over Loads Charges radiales [N]	Rad. Yük Over Loads Charges radiales [N]					
<b>200 Nm</b>		0,37	17	83,71	200	475	4500	<b>YP YPF</b>	<b>53</b>	99 100	18 20	
		0,41	19	74,40	200	475	4500					
		0,46	21	66,47	200	475	4500					
		0,51	23	59,64	200	475	4500					
		0,57	26	53,68	200	475	4500					
		0,63	29	48,45	200	475	4500					
		0,70	32	43,81	200	475	4500					
		0,78	35	39,46	200	475	4500					
		0,87	40	35,07	200	475	4500					
		0,98	45	31,33	200	475	4500					
		1,1	50	28,11	200	475	4500					
		1,2	55	25,30	200	475	4500					
		1,3	61	22,84	200	475	4500					
		1,2	54	25,75	200	475	4500					
		1,4	63	22,33	200	475	4500					
		1,5	72	19,56	200	475	4500					
		1,7	81	17,27	200	475	4500					
		2,0	91	15,35	200	475	4000					
		2,2	102	13,72	200	475	4000					
		2,5	114	12,31	200	475	4000					
		2,7	126	11,08	200	475	4000					
		3,0	140	10,00	200	475	4000					
		3,3	155	9,04	200	475	4000					
		3,5	163	8,59	200	475	4000					
		4,0	184	7,60	200	475	3500					
		4,2	193	7,24	200	475	3500					
		4,7	217	6,47	200	475	3500					
		5,2	241	5,80	200	475	3500					
	5,8	268	5,22	200	475	3500						
	6,4	297	4,71	200	475	3500						
	7,1	328	4,26	200	475	3500						
	7,5	346	4,05	200	475	3500						
	8,4	391	3,58	200	475	3500						
<b>400 Nm</b>		0,01	0,12	11636	400	390	7000	<b>YP YPF</b>	<b>63 İR 43</b>	105 106	39 41	
		0,01	0,13	11047	400	390	7000					
		0,01	0,15	9603	400	390	7000					
		0,01	0,18	7948	400	390	7000					
		0,01	0,19	7409	400	390	7000					
		0,01	0,22	6489	400	390	7000					
		0,01	0,25	5626	400	390	7000					
		0,01	0,29	4838	400	390	7000					
		0,01	0,32	4400	400	390	7000					
		0,02	0,36	3876	400	390	7000					
		0,02	0,43	3237	400	390	7000					
		0,02	0,46	3060	400	390	7000					
		0,02	0,51	2729	400	390	7000					
		0,03	0,57	2473	400	390	7000					
		0,03	0,70	1996	400	390	7000					
		0,02	0,55	2566	400	390	7000					
		0,03	0,63	2209	400	390	7000					
		0,03	0,73	1920	400	390	7000					
		0,04	0,83	1682	400	390	7000					
		0,04	0,93	1509	400	390	7000					
		0,04	1,00	1407	400	390	7000					
		0,05	1,1	1220	400	390	7000					
		0,06	1,3	1105	400	390	7000					
		0,06	1,4	1005	400	390	7000					
									<b>YP YPF</b>	<b>62 İR 43</b>	105 106	36 38



Servis Faktörü Service Factor Service facteur	S <sub>r</sub> =1 S <sub>f</sub> =1 S <sub>f</sub> =1	P <sub>1</sub>	n <sub>2</sub>	i	M <sub>2</sub>	F <sub>Q1</sub>	F <sub>Q10</sub>	Tip Type		
		GÜÇ Power Puissance [kW]	Çıkış Devri Output Speeds Vitesse de sortie [r.p.m] (n <sub>1</sub> =1400rpm)	Tahvil Ratio Rapport de réduction	Çıkış Momenti Output Torque Couple de sortie [Nm]	Rad. Yük Over Loads Charges radiales [N]	Rad. Yük Over Loads Charges radiales [N]			
<b>400 Nm</b>	0,07	1,6	893	400	390	7000	YP YPF	62 İR 43	105 106	36 38
	0,08	1,7	809	400	390	7000				
	0,09	2,0	707	400	390	7000				
	0,10	2,3	619	400	390	7000				
	0,12	2,6	538	400	390	7000				
	0,13	2,9	491	400	390	7000				
	0,15	3,2	433	400	390	7000				
	0,17	3,7	382	400	390	7000				
	0,19	4,1	338	400	390	7000				
	0,21	4,7	300	400	390	7000				
	0,24	5,2	267	400	390	7000				
	0,03	0,75	1867	400	390	7000				
	0,04	0,79	1773	400	390	7000				
	0,04	0,95	1467	400	390	7000				
	0,05	1,0	1368	400	390	7000				
	0,05	1,2	1198	400	390	7000				
	0,06	1,3	1055	400	390	7000				
	0,07	1,5	915	400	390	7000				
	0,08	1,8	787	400	390	7000				
	0,09	2,0	715	400	390	7000				
	0,11	2,3	598	400	390	7000				
	0,11	2,5	552	400	390	7000				
	0,14	3,1	457	400	390	7000				
	0,17	3,8	366	400	390	7000				
	0,19	4,2	333	400	390	7000				
	0,23	5,0	278	400	390	7000				
	0,27	6,0	234	400	390	7000				
	0,30	6,7	210	400	390	7000				
	0,34	7,5	186	400	390	7000				
	0,37	8,3	169	400	390	7000				
	0,42	9,3	150	400	390	7000				
	0,48	11	133	400	390	7000				
	0,54	12	118	400	390	7000				
	0,18	3,9	355	400	390	7000				
	0,22	5,0	279	400	390	7000				
	0,24	5,4	260	400	390	7000				
	0,28	6,2	225	400	390	7000				
	0,31	6,9	204	400	390	7000				
	0,35	7,8	179	400	390	7000				
	0,38	8,6	162	400	390	7000				
	0,43	9,7	144	400	390	7000				
	0,48	11	131	400	390	7000				
	0,32	7,4	190,17	400	590	7000				
	0,35	7,9	177,47	400	590	7000				
	0,37	8,4	166,10	400	590	7000				
	0,39	8,9	157,69	400	590	7000				
	0,47	11	130,52	400	590	7000				
	0,50	12	121,67	400	590	7000				
0,58	13	105,48	400	590	7000					
0,68	15	90,72	400	590	7000					
0,74	17	82,51	400	590	7000					
0,89	20	68,90	400	590	7000					
0,94	21	65,14	400	590	7000					
0,96	22	63,66	400	590	7000					
1,1	24	58,09	400	590	7000					
							YP YPF	63	103 104	32 34



Servis Faktörü Service Factor Service facteur	S <sub>r</sub> =1 S <sub>f</sub> =1 S <sub>f</sub> =1	P <sub>1</sub>	n <sub>2</sub>	i	M <sub>2</sub>	F <sub>Q1</sub>	F <sub>Q10</sub>	Tip Type			
		GÜÇ Power Puissance [kW]	Çıkış Devri Output Speeds Vitesse de sortie [r.p.m] (n <sub>1</sub> =1400rpm)	Tahvil Ratio Rapport de réduction	Çıkış Momenti Output Torque Couple de sortie [Nm]	Rad. Yük Over Loads Charges radiales [N]	Rad. Yük Over Loads Charges radiales [N]				
400 Nm		1,2	27	52,64	400	590	7000	YP YPF	63	103 104	32 34
		1,3	29	47,69	400	590	7000				
		1,4	32	43,37	400	590	7000				
		1,7	39	36,22	400	590	7000				
		2,0	46	30,54	400	590	7000				
		1,9	44	31,54	400	590	6350	YP YPF	62	103 104	29 31
		2,4	56	24,78	400	590	6350				
		2,6	61	23,10	400	590	6350				
		3,0	70	20,03	400	590	6350				
		3,3	77	18,14	400	590	6350				
		3,7	85	16,50	400	590	6350				
		4,1	95	14,67	400	590	6350				
		4,5	105	13,29	400	590	6350				
		5,0	116	12,09	400	590	6350				
		5,2	121	11,62	400	590	6350				
		6,0	139	10,09	400	590	6350				
		6,6	152	9,21	400	590	6350				
		7,1	165	8,51	400	590	6350				
		7,4	172	8,13	400	590	6350				
		8,4	194	7,20	400	590	6350				
	9,5	219	6,39	400	590	6350					
	10,6	247	5,68	400	590	6350					
800 Nm		0,01	0,07	19587	800	475	13500	YP YPF	73 İR 53	111 112	66 70
		0,01	0,08	16495	800	475	13500				
		0,01	0,10	14304	800	475	13500				
		0,01	0,11	12691	800	475	13500				
		0,01	0,12	11240	800	475	13500				
		0,01	0,14	9972	800	475	13500				
		0,01	0,16	8621	800	475	13500				
		0,02	0,20	6967	800	475	13500				
		0,02	0,24	5921	800	475	13500				
		0,02	0,26	5364	800	475	13500				
		0,03	0,28	4914	800	475	13500				
		0,03	0,35	3972	800	475	13500				
		0,04	0,41	3375	800	475	13500				
		0,04	0,46	3058	800	475	13500				
		0,05	0,50	2781	800	475	13500				
		0,06	0,60	2322	800	475	13500				
		0,06	0,64	2178	800	475	13500				
		0,06	0,71	1981	800	475	13500				
		0,08	0,85	1654	800	475	13500				
		0,04	0,40	3481	800	475	13500				
		0,04	0,47	2958	800	475	13500				
		0,05	0,54	2609	800	475	13500				
		0,05	0,60	2320	800	475	13500				
		0,06	0,65	2160	800	475	13500				
		0,07	0,73	1905	800	475	13500				
		0,07	0,83	1694	800	475	13500				
		0,08	0,91	1534	800	475	13500				
		0,09	1,0	1355	800	475	13500				
		0,11	1,2	1204	800	475	13500				
		0,12	1,3	1076	800	475	13500				
		0,13	1,5	965	800	475	13500				
		0,14	1,6	875	800	475	13500				
	0,16	1,8	772	800	475	13500					



Servis Faktörü Service Factor Service facteur	S <sub>f</sub> = 1 S <sub>f</sub> = 1 S <sub>f</sub> = 1	P <sub>1</sub>	n <sub>2</sub>	i	M <sub>2</sub>	F <sub>Q1</sub>	F <sub>Q10</sub>	Tip Type			
		GÜÇ Power Puissance [kW]	Çıkış Devri Output Speeds Vitesse de sortie [r.p.m] (n <sub>1</sub> =1400rpm)	Tahvil Ratio Rapport de réduction	Çıkış Momenti Output Torque Couple de sortie [Nm]	Rad. Yük Over Loads Charges radiales [N]	Rad. Yük Over Loads Charges radiales [N]				
<b>800 Nm</b>		0,18	2,0	686	800	475	13500	YP YPF	72 İR 53	111 112	63 67
	0,21	2,3	613	800	475	13500					
	0,23	2,5	550	800	475	13500					
	0,26	2,8	495	800	475	13500					
	0,28	3,1	447	800	475	13500					
	0,31	3,5	404	800	475	13500					
	0,05	0,56	2503	800	475	13500	YP YPF	73 İR 52	111 112	65 69	
	0,06	0,63	2220	800	475	13500					
	0,07	0,73	1919	800	475	13500					
	0,08	0,90	1551	800	475	13500					
	0,10	1,1	1318	800	475	13500					
	0,11	1,2	1194	800	475	13500					
	0,12	1,3	1086	800	475	13500					
	0,14	1,5	907	800	475	13500					
	0,15	1,7	840	800	475	13500					
	0,18	2,0	702	800	475	13500					
	0,19	2,1	665	800	475	13500					
	0,21	2,4	591	800	475	13500					
	0,22	2,5	565	800	475	13500					
	0,25	2,8	500	800	475	13500					
	0,22	2,5	566	800	475	13500	YP YPF	72 İR 52	111 112	62 66	
	0,26	2,9	482,98	800	475	13500	YP YPF	74	109 110	39 43	
	0,29	3,3	428,50	800	475	13500					
	0,34	3,8	370,44	800	475	13500					
	0,42	4,7	299,38	800	475	13500					
	0,49	5,5	254,24	800	475	13500					
	0,54	6,1	230,48	800	475	13500					
	0,58	6,6	212,23	800	590	13500					
	0,62	7,1	198,05	800	590	13500					
	0,66	7,6	185,37	800	590	13500	YP YPF	73	107 108	53 57	
	0,75	8,5	164,46	800	590	13500					
	0,84	9,6	145,66	800	590	13500					
	0,95	11	129,23	800	590	13500					
	1,1	13	111,72	800	590	13500					
	1,4	16	90,29	800	590	12500					
	1,6	18	76,73	800	590	12500					
	1,8	20	69,51	800	590	12500					
	1,9	22	63,22	800	590	12500					
	2,3	27	52,79	800	590	12500					
	2,5	28	50,03	800	590	12500					
2,8	31	44,51	800	590	12000						
2,9	33	42,51	800	590	12000						
3,3	37	37,65	800	590	12000						
3,7	42	33,42	800	590	12000						
4,1	47	29,69	800	590	12000	YP YPF	72	107 108	50 54		
3,7	42	32,94	800	590	12000						
4,3	50	28,00	800	590	12000						
4,9	57	24,69	800	590	12000						
5,5	64	21,96	800	590	12000						
6,1	70	19,89	800	590	12000						
6,9	80	17,56	800	590	12000						
7,7	90	15,61	800	590	12000						
8,7	100	13,95	800	590	11000						
9,7	112	12,51	800	590	11000						
10,7	124	11,26	800	590	11000						
11,9	138	10,17	800	590	11000						







Servis Faktörü Service Factor Service facteur	S <sub>f</sub> =1 S <sub>f</sub> =1 S <sub>f</sub> =1	P <sub>1</sub>	n <sub>2</sub>	i	M <sub>2</sub>	F <sub>Q1</sub>	F <sub>Q10</sub>	Tip Type			
		GÜÇ Power Puissance [kW]	Çıkış Devri Output Speeds Vitesse de sortie [r.p.m] (n <sub>1</sub> =1400rpm)	Tahvil Ratio Rapport de réduction	Çıkış Momenti Output Torque Couple de sortie [Nm]	Rad. Yük Over Loads Charges radiales [N]	Rad. Yük Over Loads Charges radiales [N]				kg
<b>800 Nm</b>		13,1	152	9,19	800	590	11000	YP YPF	72	107 108	50 54
		14,5	168	8,33	800	590	11000				
		15,4	179	7,83	800	590	10500				
		16,0	185	7,55	800	590	10500				
		17,3	200	7,00	800	590	10500				
		19,3	223	6,28	800	590	10000				
		21,4	248	5,65	800	590	10000				
		23,7	275	5,10	800	590	10000				
		26,2	304	4,61	800	590	10000				
		28,9	335	4,18	800	590	10000				
	31,9	370	3,79	800	590	10000					
<b>1500 Nm</b>		0,01	0,07	21318	1500	475	17250	YP YPF	83 İR 53	117 118	95 101
		0,01	0,08	18430	1500	475	17250				
		0,02	0,09	15520	1500	475	17250				
		0,02	0,10	13459	1500	475	17250				
		0,02	0,12	11791	1500	475	17250				
		0,02	0,13	10554	1500	475	17250				
		0,03	0,15	9308	1500	475	17250				
		0,03	0,17	8437	1500	475	17250				
		0,03	0,19	7547	1500	475	17250				
		0,04	0,21	6712	1500	475	17250				
		0,04	0,23	6010	1500	475	17250				
		0,04	0,26	5420	1500	475	17250				
		0,05	0,29	4786	1500	475	17250				
		0,06	0,32	4349	1500	475	17250				
		0,06	0,35	3944	1500	475	17250				
		0,07	0,42	3302	1500	475	17250				
		0,08	0,48	2944	1500	475	17250				
		0,09	0,53	2643	1500	475	17250				
		0,10	0,59	2387	1500	475	17250				
		0,11	0,66	2121	1500	475	17250				
		0,09	0,51	2730	1500	475	17250				
		0,10	0,61	2299	1500	475	17250				
		0,12	0,68	2050	1500	475	17250				
		0,13	0,79	1778	1500	475	17250				
		0,15	0,90	1558	1500	475	17250				
		0,19	1,1	1263	1500	475	17250				
		0,21	1,3	1115	1500	475	17250				
		0,23	1,4	1013	1500	475	17250				
		0,26	1,5	918	1500	475	17250				
		0,29	1,7	822	1500	475	17250				
		0,13	0,74	1884	1500	475	17250				
		0,14	0,82	1699	1500	475	17250				
		0,15	0,91	1540	1500	475	17250				
		0,18	1,1	1290	1500	475	17250				
		0,21	1,2	1130	1500	475	17250				
		0,24	1,4	998	1500	475	17250				
		0,27	1,6	890	1500	475	17250				
		0,30	1,8	799	1500	475	17250				
		0,33	1,9	721	1500	475	17250				
		0,37	2,2	641	1500	475	17250				
	0,35	2,1	663,81	1500	475	17250					
	0,39	2,4	594,20	1500	475	17250					
	0,44	2,6	528,44	1500	475	17250					
	0,49	3,0	473,20	1500	475	17250					
							YP YPF	84	111 112	76 82	





Servis Faktörü Service Factor Service facteur	S <sub>f</sub> = 1 S <sub>f</sub> = 1 S <sub>f</sub> = 1	P <sub>1</sub>	n <sub>2</sub>	i	M <sub>2</sub>	F <sub>Q1</sub>	F <sub>Q10</sub>	Tip Type			
		GÜÇ Power Puissance [kW]	Çıkış Devri Output Speeds Vitesse de sortie [r.p.m] (n <sub>1</sub> =1400rpm)	Tahvil Ratio Rapport de réduction	Çıkış Momenti Output Torque Couple de sortie [Nm]	Rad. Yük Over Loads Charges radiales [N]	Rad. Yük Over Loads Charges radiales [N]				
<b>1500 Nm</b>		0,55	3,3	426,64	1500	475	17250	YP YPF	84	115 116	76 82
		0,61	3,6	384,21	1500	475	17250				
		0,72	4,3	323,97	1500	475	17250				
		0,81	4,8	288,84	1500	475	17250				
		0,90	5,4	259,33	1500	475	17250				
		0,95	5,8	242,30	1500	1200	17250	YP YPF	83	113 114	83 89
		1,1	6,7	209,47	1500	1200	17250				
		1,1	6,9	201,75	1500	1200	17250				
		1,3	8,0	174,42	1500	1200	17250				
		1,5	9,0	156,13	1500	1200	17250				
		1,5	9,1	153,81	1500	1200	17250				
		1,7	10	137,68	1500	1200	17250				
		1,9	11	122,44	1500	1200	17250				
		2,1	13	109,64	1500	1200	17250				
		2,3	14	98,86	1500	1200	17250				
		2,6	16	89,02	1500	1200	17250				
		3,1	19	75,07	1500	1200	17250				
		3,4	21	66,93	1500	1200	17250				
		3,8	23	60,09	1500	1200	17250				
		4,2	26	54,26	1500	1200	17250				
		4,8	29	48,22	1500	1200	17250				
		5,4	33	42,58	1500	1200	17250				
		6,8	41	33,81	1500	1200	17250				
		7,6	46	30,34	1500	1200	17250				
		8,4	51	27,31	1500	1200	17250				
		9,3	57	24,65	1500	1200	17250				
		10,3	63	22,29	1500	1200	17250				
		8,8	54	25,84	1500	1200	14500				
		9,8	61	23,04	1500	1200	14500				
		11,0	68	20,69	1500	1200	14500				
		12,1	75	18,68	1500	1200	14500				
		13,7	84	16,60	1500	1200	14500				
		15,2	94	14,90	1500	1200	14500				
		16,9	104	13,43	1500	1200	14500				
		19,0	117	11,94	1500	1200	14500				
		19,6	121	11,57	1500	1200	14500				
		20,6	127	11,03	1500	1200	14500				
		21,7	134	10,45	1500	1200	14500				
		22,6	140	10,03	1500	1200	14500				
		24,4	151	9,29	1500	1200	14500				
	27,2	168	8,33	1500	1200	14500					
	30,2	186	7,51	1500	1200	14500					
	34,0	210	6,67	1500	1200	14500					
	36,7	227	6,17	1500	1200	14500					
	40,4	249	5,61	1500	1200	14500					
	44,3	274	5,12	1500	1200	14500					
	48,5	300	4,67	1500	1200	14500					
	53,1	328	4,27	1500	1200	14500					
<b>3000 Nm</b>		0,02	0,06	22924	3000	590	25000	YP YPF	93 İR 63	123 124	137 140
		0,02	0,07	20793	3000	590	25000				
		0,03	0,08	18471	3000	590	25000				
		0,03	0,09	16468	3000	590	25000				
		0,03	0,10	13798	3000	590	25000				
		0,04	0,11	12460	3000	590	25000				
		0,04	0,13	11072	3000	590	25000				
		0,05	0,14	10315	3000	590	25000				
		0,05	0,15	9197	3000	590	25000				





Servis Faktörü Service Factor Service facteur	S <sub>f</sub> = 1 S <sub>f</sub> = 1 S <sub>f</sub> = 1	P <sub>1</sub>	n <sub>2</sub>	i	M <sub>2</sub>	F <sub>Q1</sub>	F <sub>Q10</sub>	Tip Type		
		GÜÇ Power Puissance [kW]	Çıkış Devri Output Speeds Vitesse de sortie [r.p.m] (n <sub>1</sub> =1400rpm)	Tahvil Ratio Rapport de réduction	Çıkış Momenti Output Torque Couple de sortie [Nm]	Rad. Yük Over Loads Charges radiales [N]	Rad. Yük Over Loads Charges radiales [N]			
3000 Nm	0,06	0,17	8257	3000	590	25000	YP YPF	93 İR 63	123 124	137 140
	0,06	0,19	7457	3000	590	25000				
	0,08	0,22	6372	3000	590	25000				
	0,08	0,24	5744	3000	590	25000				
	0,09	0,27	5198	3000	590	25000				
	0,10	0,30	4717	3000	590	25000				
	0,11	0,32	4402	3000	590	25000				
	0,12	0,35	4005	3000	590	25000				
	0,13	0,38	3650	3000	590	25000				
	0,13	0,39	3571	3000	590	25000				
	0,14	0,42	3333	3000	590	25000				
	0,12	0,34	4089	3000	590	25000				
	0,13	0,38	3690	3000	590	25000				
	0,14	0,42	3350	3000	590	25000				
	0,17	0,50	2802	3000	590	25000				
	0,17	0,51	2731	3000	590	25000				
	0,19	0,55	2548	3000	590	25000				
	0,21	0,62	2246	3000	590	25000				
	0,24	0,70	1996	3000	590	25000				
	0,27	0,78	1789	3000	590	25000				
	0,30	0,87	1607	3000	590	25000				
	0,33	0,96	1453	3000	590	25000				
	0,36	1,1	1319	3000	590	25000				
	0,40	1,2	1200	3000	590	25000				
	0,43	1,3	1096	3000	590	25000				
	0,55	1,6	863	3000	590	25000				
	0,61	1,8	772	3000	590	25000				
	0,12	0,36	3852	3000	590	25000				
	0,14	0,41	3400	3000	590	25000				
	0,17	0,49	2870	3000	590	25000				
	0,18	0,52	2678	3000	590	25000				
	0,22	0,64	2190	3000	590	25000				
	0,24	0,72	1945	3000	590	25000				
	0,27	0,81	1734	3000	590	25000				
	0,30	0,90	1557	3000	590	25000				
	0,38	1,1	1249	3000	590	25000				
	0,41	1,2	1164	3000	590	25000				
	0,46	1,3	1038	3000	590	25000				
	0,51	1,5	932	3000	590	25000				
	0,56	1,7	842	3000	590	25000				
	0,63	1,9	748	3000	590	25000				
	0,60	1,8	781,59	3000	590	25000				
	0,66	2,0	712,53	3000	590	25000				
	0,72	2,1	652,38	3000	590	25000				
	0,78	2,3	599,52	3000	590	25000				
	0,83	2,5	563,99	3000	590	25000				
	0,90	2,7	518,29	3000	590	25000				
	1,1	3,2	433,91	3000	590	25000				
1,2	3,6	385,58	3000	590	25000					
1,3	3,9	359,21	3000	590	25000					
1,5	4,4	320,26	3000	590	25000					
1,6	4,9	285,83	3000	1550	25000					
1,8	5,5	252,35	3000	1550	25000					
2,0	5,9	235,39	3000	1550	25000					
2,1	6,3	222,00	3000	1550	25000					
2,2	6,6	213,04	3000	1550	25000					
2,3	7,0	198,72	3000	1550	25000					
2,6	7,8	179,17	3000	1550	25000					





Servis Faktörü Service Factor Service facteur	S <sub>f</sub> =1 S <sub>f</sub> =1 S <sub>f</sub> =1	P <sub>1</sub>	n <sub>2</sub>	i	M <sub>2</sub>	F <sub>Q1</sub>	F <sub>Q10</sub>	Tip Type			
		GÜÇ Power Puissance [kW]	Çıkış Devri Output Speeds Vitesse de sortie [r.p.m] (n <sub>1</sub> =1400rpm)	Tahvil Ratio Rapport de réduction	Çıkış Momenti Output Torque Couple de sortie [Nm]	Rad. Yük Over Loads Charges radiales [N]	Rad. Yük Over Loads Charges radiales [N]				
<b>3000 Nm</b>		2,8	8,6	162,51	3000	1550	25000	YP YPF	93	119 120	115 118
		3,2	9,7	144,37	3000	1550	25000				
		3,6	11	128,71	3000	1550	25000				
		4,0	12	115,56	3000	1550	25000				
		4,4	13	104,36	3000	1550	25000				
		5,0	15	92,73	3000	1550	25000				
		5,3	16	86,39	3000	1550	25000				
		6,0	18	77,02	3000	1550	25000				
		6,7	20	69,15	3000	1550	25000				
		7,4	22	62,45	3000	1550	25000				
		8,3	25	55,49	3000	1550	25000				
		9,2	28	49,80	3000	1550	25000				
		10,3	31	44,90	3000	1550	25000				
		11,3	34	40,62	3000	1550	25000				
		12,5	38	36,87	3000	1550	25000				
		13,7	42	33,54	3000	1550	25000				
		15,1	46	30,57	3000	1550	25000				
		16,5	50	27,91	3000	1550	25000				
		14,2	44	31,96	3000	1550	21000				
		15,7	49	28,84	3000	1550	21000				
		17,3	53	26,19	3000	1550	21000				
		20,7	64	21,90	3000	1550	21000				
		21,2	66	21,34	3000	1550	21000				
		24,1	74	18,81	3000	1550	21000				
		27,1	84	16,72	3000	1550	21000				
		30,3	94	14,96	3000	1550	21000				
		33,7	104	13,46	3000	1550	21000				
		37,3	115	12,17	3000	1550	21000				
		41,0	127	11,04	3000	1550	21000				
		45,1	139	10,05	3000	1550	21000				
		49,4	153	9,18	3000	1550	21000				
		54,0	167	8,40	3000	1550	21000				
	58,9	182	7,70	3000	1550	21000					
	69,8	216	6,49	3000	1550	21000					
	76,0	235	5,97	3000	1550	21000					
	82,6	255	5,49	3000	1550	21000					
	110	340	4,12	3000	1550	21000					
<b>4300 Nm</b>		0,02	0,05	28324	4300	590	30000	YP YPF	103 İR 63	129 130	201 221
		0,03	0,05	26432	4300	590	30000				
		0,03	0,06	23476	4300	590	30000				
		0,03	0,06	21582	4300	590	30000				
		0,04	0,07	19168	4300	590	30000				
		0,04	0,08	17174	4300	590	30000				
		0,04	0,09	15499	4300	590	30000				
		0,05	0,10	14072	4300	590	30000				
		0,06	0,12	11940	4300	590	30000				
		0,06	0,13	10684	4300	590	30000				
		0,08	0,16	8941	4300	590	30000				
		0,09	0,18	7880	4300	590	30000				
		0,10	0,20	7003	4300	590	30000				
		0,11	0,22	6266	4300	590	30000				
		0,12	0,25	5638	4300	590	30000				
		0,14	0,27	5097	4300	590	30000				
		0,16	0,33	4212	4300	590	30000				
		0,18	0,36	3845	4300	590	30000				
		0,20	0,41	3443	4300	590	30000				
		0,24	0,48	2887	4300	590	30000				





Servis Faktörü Service Factor Service facteur	S <sub>f</sub> = 1 S <sub>f</sub> = 1 S <sub>f</sub> = 1	P <sub>1</sub>	n <sub>2</sub>	i	M <sub>2</sub>	F <sub>Q1</sub>	F <sub>Q10</sub>	Tip Type		
		GÜÇ Power Puissance [kW]	Çıkış Devri Output Speeds Vitesse de sortie [r.p.m] (n <sub>1</sub> =1400rpm)	Tahvil Ratio Rapport de réduction	Çıkış Momenti Output Torque Couple de sortie [Nm]	Rad. Yük Over Loads Charges radiales [N]	Rad. Yük Over Loads Charges radiales [N]			
4300 Nm	0,20	0,41	3375	4300	590	30000	YP YPF	102 İR 63	129 130	201 221
	0,22	0,45	3111	4300	590	30000				
	0,26	0,53	2658	4300	590	30000				
	0,27	0,56	2480	4300	590	30000				
	0,31	0,63	2206	4300	590	30000				
	0,34	0,71	1976	4300	590	30000				
	0,38	0,79	1779	4300	590	30000				
	0,42	0,87	1611	4300	590	30000				
	0,47	0,96	1462	4300	590	30000				
	0,51	1,1	1333	4300	590	30000				
	0,56	1,1	1218	4300	590	30000				
	0,61	1,3	1113	4300	590	30000				
	0,68	1,4	1005	4300	590	30000				
	0,75	1,5	909	4300	590	30000				
	0,83	1,7	823	4300	590	30000				
	0,19	0,38	3640	4300	590	30000				
	0,20	0,41	3395	4300	590	30000				
	0,23	0,47	2983	4300	590	30000				
	0,26	0,53	2649	4300	590	30000				
	0,28	0,57	2436	4300	590	30000				
	0,31	0,65	2163	4300	590	30000				
	0,35	0,72	1938	4300	590	30000				
	0,39	0,80	1749	4300	590	30000				
	0,43	0,88	1588	4300	590	30000				
	0,50	1,0	1347	4300	590	30000				
	0,56	1,2	1206	4300	590	30000				
	0,67	1,4	1009	4300	590	30000				
	0,76	1,6	889	4300	590	30000				
	0,86	1,8	790	4300	590	30000				
	0,96	2,0	707	4300	590	30000				
	1,1	2,2	636	4300	590	30000				
	0,78	1,6	855	4300	590	30000				
	0,87	1,8	771	4300	590	30000				
	0,95	2,0	709	4300	590	30000				
	1,1	2,2	629	4300	590	30000				
	1,2	2,5	564	4300	590	30000				
	1,3	2,8	509	4300	590	30000				
	1,4	3,0	462	4300	590	30000				
	1,7	3,6	392	4300	590	30000				
	1,9	4,0	351	4300	590	30000				
2,3	4,8	294	4300	590	30000					
2,6	5,4	259	4300	590	30000					
2,9	6,1	230	4300	590	30000					
3,3	6,8	206	4300	590	30000					
2,4	5,2	270,11	4300	2500	30000					
2,6	5,6	251,95	4300	2500	30000					
3,0	6,3	221,37	4300	2500	30000					
3,4	7,1	196,61	4300	2500	30000					
3,6	7,7	180,75	4300	2500	30000					
4,1	8,7	160,54	4300	2500	30000					
4,6	9,7	143,83	4300	2500	30000					
5,1	11	129,80	4300	2500	30000					
5,6	12	117,86	4300	2500	30000					
6,6	14	100,00	4300	2500	30000					
7,4	16	89,48	4300	2500	30000					
8,8	19	74,89	4300	2500	30000					
10,0	21	65,99	4300	2500	30000					
						YP YPF	103	125 126	188 208	





Servis Faktörü Service Factor Service facteur	S <sub>f</sub> = 1 S <sub>f</sub> = 1 S <sub>f</sub> = 1	P <sub>1</sub>	n <sub>2</sub>	i	M <sub>2</sub>	F <sub>Q1</sub>	F <sub>Q10</sub>	Tip Type			
		GÜÇ Power Puissance [kW]	Çıkış Devri Output Speeds Vitesse de sortie [r.p.m] (n <sub>1</sub> =1400rpm)	Tahvil Ratio Rapport de réduction	Çıkış Momenti Output Torque Couple de sortie [Nm]	Rad. Yük Over Loads Charges radiales [N]	Rad. Yük Over Loads Charges radiales [N]				
4300 Nm		11,2	24	58,65	4300	2500	30000	YP YPF	103	125 126	188 208
		12,6	27	52,48	4300	2500	30000				
		14,0	30	47,22	4300	2500	30000				
		15,5	33	42,69	4300	2500	30000				
		18,7	40	35,28	4300	2500	30000				
		20,5	43	32,20	4300	2500	30000				
		22,9	49	28,84	4300	2500	30000				
		27,3	58	24,18	4300	2500	30000				
		32,3	69	20,39	4300	2500	30000				
		24,6	53	26,38	4300	2500	29000				
		26,7	58	24,31	4300	2500	29000				
		31,3	67	20,78	4300	2500	29000				
		35,2	76	18,48	4300	2500	29000				
		39,3	85	16,55	4300	2500	29000				
		43,6	94	14,90	4300	2500	29000				
		48,2	104	13,48	4300	2500	29000				
		53,1	114	12,25	4300	2500	29000				
		58,2	125	11,16	4300	2500	29000				
		63,7	137	10,20	4300	2500	29000				
		69,7	150	9,32	4300	2500	29000				
		77,2	166	8,41	4300	2500	29000				
		85,4	184	7,61	4300	2500	29000				
		94,3	203	6,89	4300	2500	29000				
		104	224	6,25	4300	2500	29000				
		114	245	5,72	4300	2500	29000				
	125	270	5,18	4300	2500	29000					
	138	298	4,70	4300	2500	29000					
7800 Nm		0,05	0,05	27038	7800	1200	61000	YP YPF	123 İR 73	135 136	295 325
		0,06	0,06	22187	7800	1200	61000				
		0,06	0,07	20263	7800	1200	61000				
		0,08	0,09	16312	7800	1200	61000				
		0,08	0,10	14732	7800	1200	61000				
		0,11	0,12	11572	7800	1200	61000				
		0,13	0,14	9695	7800	1200	61000				
		0,14	0,16	8644	7800	1200	61000				
		0,16	0,18	7633	7800	1200	61000				
		0,18	0,21	6784	7800	1200	61000				
		0,21	0,23	6061	7800	1200	61000				
		0,23	0,26	5438	7800	1200	61000				
		0,26	0,29	4895	7800	1200	61000				
		0,28	0,32	4418	7800	1200	61000				
		0,32	0,36	3884	7800	1200	61000				
		0,35	0,39	3619	7800	1200	61000				
		0,38	0,43	3281	7800	1200	61000				
		0,49	0,55	2545	7800	1200	61000				
		0,56	0,62	2245	7800	1200	61000				
		0,24	0,28	5076	7800	1200	61000				
		0,28	0,32	4389	7800	1200	61000				
		0,30	0,34	4120	7800	1200	61000				
		0,32	0,37	3826	7800	1200	61000				
		0,35	0,39	3563	7800	1200	61000				
		0,41	0,47	3003	7800	1200	61000				
	0,51	0,57	2437	7800	1200	61000					
	0,61	0,69	2036	7800	1200	61000					
	0,69	0,78	1792	7800	1200	61000					
								YP YPF	122 İR 73	135 136	295 325





Servis Faktörü Service Factor Service facteur	S <sub>f</sub> = 1 S <sub>f</sub> = 1 S <sub>f</sub> = 1	P <sub>1</sub>	n <sub>2</sub>	i	M <sub>2</sub>	F <sub>Q1</sub>	F <sub>Q10</sub>	Tip Type			
		GÜÇ Power Puissance [kW]	Çıkış Devri Output Speeds Vitesse de sortie [r.p.m] (n <sub>1</sub> =1400rpm)	Tahvil Ratio Rapport de réduction	Çıkış Momenti Output Torque Couple de sortie [Nm]	Rad. Yük Over Loads Charges radiales [N]	Rad. Yük Over Loads Charges radiales [N]				kg
<b>7800 Nm</b>		0,72	0,81	1724	7800	1200	61000	YP YPF	122 İR 73	135 136	295 325
		0,88	1,0	1400	7800	1200	61000				
		1,1	1,2	1169	7800	1200	61000				
		1,2	1,4	1029	7800	1200	61000				
		1,4	1,5	913	7800	1200	61000				
		1,5	1,7	831	7800	1200	61000				
		0,36	0,41	3380	7800	1200	61000	YP YPF	123 İR 72	135 136	288 318
		0,42	0,47	2971	7800	1200	61000				
		0,47	0,53	2641	7800	1200	61000				
		0,52	0,59	2368	7800	1200	61000				
		0,58	0,65	2138	7800	1200	61000				
		0,68	0,77	1821	7800	1200	61000				
		0,76	0,86	1633	7800	1200	61000				
		0,84	0,95	1475	7800	1200	61000				
		0,94	1,1	1316	7800	1200	61000				
		1,1	1,3	1092	7800	1200	61000				
		1,2	1,4	1002	7800	1200	61000				
		1,6	1,8	794	7800	1200	61000				
		1,7	2,0	713	7800	1200	61000				
		1,6	1,8	761,08	7800	1200	61000				
		1,8	2,0	687,35	7800	1200	61000				
		1,9	2,2	624,54	7800	1200	61000				
		2,1	2,5	567,16	7800	1200	61000				
		2,4	2,7	512,21	7800	1200	61000				
		2,6	3,0	465,40	7800	1200	61000				
		2,9	3,3	425,05	7800	1200	61000				
		3,1	3,6	389,91	7800	1200	61000				
		3,6	4,1	342,17	7800	1200	61000				
		3,9	4,5	309,02	7800	1200	61000	YP YPF	123	131 132	287 317
		4,3	5,0	280,78	7800	1200	61000				
		4,7	5,5	256,44	7800	1200	61000				
		4,8	5,6	249,87	7800	3750	61000				
		5,4	6,4	219,68	7800	3750	61000				
		6,1	7,2	195,24	7800	3750	61000				
		6,8	8,0	175,05	7800	3750	61000				
		7,6	8,9	158,09	7800	3750	61000				
		8,3	9,7	143,64	7800	3750	61000				
		9,1	11	131,19	7800	3750	61000				
		9,9	12	120,34	7800	3750	60000				
		11,3	13	105,61	7800	3750	60000				
		12,5	15	95,38	7800	3750	57700				
		13,8	16	86,66	7800	3750	57700				
		15,1	18	79,15	7800	3750	57700				
		16,5	19	72,60	7800	3750	57700				
		18,5	22	64,73	7800	3750	55500				
		20,9	24	57,16	7800	3750	55500				
		23,5	28	50,81	7800	3750	55500				
		26,4	31	45,39	7800	3750	53500				
	29,4	34	40,73	7800	3750	50000					
	32,6	38	36,66	7800	3750	50000					
	36,2	42	33,09	7800	3750	48800					
	40,0	47	29,92	7800	3750	48800					
	44,1	52	27,10	7800	3750	47000					
	48,7	57	24,57	7800	3750	47000					





Servis Faktörü Service Factor Service facteur	S <sub>f</sub> = 1 S <sub>f</sub> = 1 S <sub>f</sub> = 1	P <sub>1</sub>	n <sub>2</sub>	i	M <sub>2</sub>	F <sub>Q1</sub>	F <sub>Q10</sub>	Tip Type			
		GÜÇ Power Puissance [kW]	Çıkış Devri Output Speeds Vitesse de sortie [r.p.m] (n <sub>1</sub> =1400rpm)	Tahvil Ratio Rapport de réduction	Çıkış Momenti Output Torque Couple de sortie [Nm]	Rad. Yük Over Loads Charges radiales [N]	Rad. Yük Over Loads Charges radiales [N]				kg
<b>7800 Nm</b>		39,9	47	29,50	7800	3750	50000	YP YPF	122	131 132	282 312
		44,2	52	26,68	7800	3750	50000				
		52,9	63	22,28	7800	3750	48800				
		60,1	71	19,61	7800	3750	47000				
		67,7	80	17,40	7800	3750	47000				
		75,8	90	15,54	7800	3750	46500				
		84,4	100	13,96	7800	3750	45000				
		93,5	111	12,60	7800	3750	42200				
		103	123	11,41	7800	3750	40000				
		114	135	10,37	7800	3750	37000				
		125	148	9,45	7800	3750	36500				
		137	162	8,62	7800	3750	36000				
		143	169	8,27	7800	3750	33500				
		158	188	7,46	7800	3750	31500				
		174	207	6,76	7800	3750	29500				
		192	228	6,14	7800	3750	28350				
		211	250	5,59	7800	3750	28350				
		231	274	5,11	7800	3750	26800				
		253	300	4,67	7800	3750	26800				
		276	328	4,27	7800	3750	26800				
	301	358	3,91	7800	3750	23800					
<b>12000 Nm</b>		0,06	0,05	30635	12000	1200	75000	YP YPF	143 İR 73	141 142	503 538
		0,07	0,05	27501	12000	1200	75000				
		0,08	0,06	24868	12000	1200	75000				
		0,09	0,07	20771	12000	1200	75000				
		0,11	0,08	17956	12000	1200	75000				
		0,14	0,10	13932	12000	1200	75000				
		0,16	0,11	12260	12000	1200	75000				
		0,18	0,13	10878	12000	1200	75000				
		0,20	0,14	9718	12000	1200	75000				
		0,22	0,16	8730	12000	1200	75000				
		0,25	0,18	7581	12000	1200	75000				
		0,29	0,21	6672	12000	1200	75000				
		0,33	0,24	5920	12000	1200	75000				
		0,36	0,26	5288	12000	1200	75000				
		0,38	0,28	5010	12000	1200	75000				
		0,43	0,31	4475	12000	1200	75000				
		0,48	0,35	4020	12000	1200	75000				
		0,53	0,39	3628	12000	1200	75000				
		0,59	0,43	3286	12000	1200	75000				
		0,65	0,47	2986	12000	1200	75000				
		0,71	0,51	2720	12000	1200	75000				
		0,80	0,58	2404	12000	1200	75000				
		0,88	0,64	2177	12000	1200	75000				
		0,72	0,52	2683	12000	1200	75000				
		0,80	0,58	2408	12000	1200	75000				
		0,99	0,72	1936	12000	1200	75000				
		1,2	0,87	1617	12000	1200	75000				
		1,4	0,98	1423	12000	1200	75000				
		1,5	1,1	1261	12000	1200	75000				
		1,9	1,4	1007	12000	1200	75000				
		2,1	1,5	905	12000	1200	75000				
		2,3	1,6	851,00	12000	1550	75000				
		2,7	2,0	710,79	12000	1550	75000				
	3,1	2,2	625,48	12000	1550	75000					
	3,5	2,5	555,00	12000	1550	75000					
	3,9	2,8	495,59	12000	1550	75000					
	4,3	3,1	445,37	12000	1550	75000					
								YP YPF	144	139 140	645 695





Servis Faktörü Service Factor Service facteur	S <sub>f</sub> =1 S <sub>f</sub> =1 S <sub>f</sub> =1	P <sub>1</sub>	n <sub>2</sub>	i	M <sub>2</sub>	F <sub>Q1</sub>	F <sub>Q10</sub>	Tip Type			
		GÜÇ Power Puissance [kW]	Çıkış Devri Output Speeds Vitesse de sortie [r.p.m] (n <sub>1</sub> =1400rpm)	Tahvil Ratio Rapport de réduction	Çıkış Momenti Output Torque Couple de sortie [Nm]	Rad. Yük Over Loads Charges radiales [N]	Rad. Yük Over Loads Charges radiales [N]				
<b>12000 Nm</b>		5,0	3,6	386,81	12000	1550	75000	YP YPF	144	139 140	645 695
		5,7	4,1	340,38	12000	1550	75000				
		6,4	4,6	302,03	12000	1550	75000				
		7,1	5,2	269,81	12000	1550	75000				
		7,5	5,5	255,60	12000	1550	75000				
		8,4	6,1	228,34	12000	1550	75000				
		9,4	6,8	205,11	12000	1550	75000				
		9,3	7,1	198,33	12000	5250	75000	YP YPF	143	137 138	516 551
		10,3	7,9	178,04	12000	5250	75000				
		11,4	8,7	161,00	12000	5250	75000				
		13,7	10	134,47	12000	5250	75000				
		15,6	12	118,33	12000	5250	75000				
		17,5	13	105,00	12000	5250	75000				
		19,6	15	93,80	12000	5250	75000				
		21,8	17	84,26	12000	5250	75000				
		25,2	19	73,18	12000	5250	75000				
		28,6	22	64,40	12000	5250	75000				
		32,2	25	57,14	12000	5250	75000				
		36,1	27	51,05	12000	5250	75000				
		38,1	29	48,36	12000	5250	75000				
		42,6	32	43,20	12000	5250	75000				
		47,4	36	38,80	12000	5250	75000				
		52,6	40	35,02	12000	5250	75000				
		58,0	44	31,72	12000	5250	75000				
		63,9	49	28,82	12000	5250	75000				
		70,1	53	26,25	12000	5250	75000				
		79,3	60	23,20	12000	5250	75000				
		87,6	67	21,02	12000	5250	75000				
		66,9	52	27,09	12000	5250	75000				
		75,0	58	24,16	12000	5250	75000				
		83,5	64	21,71	12000	5250	75000				
		95,2	74	19,05	12000	5250	75000				
		107	82	17,00	12000	5250	75000				
		112	87	16,12	12000	5250	75000				
		126	97	14,39	12000	5250	75000				
		140	108	12,91	12000	5250	75000				
		156	120	11,64	12000	5250	75000				
		172	133	10,53	12000	5250	75000				
		190	146	9,56	12000	5250	75000				
		209	161	8,70	12000	5250	75000				
	235	182	7,71	12000	5250	75000					
	260	201	6,98	12000	5250	75000					
	286	221	6,33	12000	5250	75000					
	315	243	5,76	12000	5250	75000					
	378	292	4,80	12000	5250	75000					
	452	349	4,01	12000	5250	75000					
<b>18000 Nm</b>		0,09	0,04	32080	18000	1550	110000	YP YPF	153 İR 83	149 150	868 908
		0,10	0,05	28248	18000	1550	110000				
		0,11	0,06	25318	18000	1550	110000				
		0,13	0,06	22857	18000	1550	110000				
		0,14	0,07	20732	18000	1550	110000				
		0,16	0,08	17883	18000	1550	110000				
		0,17	0,08	17340	18000	1550	110000				
		0,18	0,09	15716	18000	1550	110000				
		0,19	0,09	15308	18000	1550	110000				
		0,21	0,10	13839	18000	1550	110000				
		0,21	0,10	13655	18000	1550	110000				



Servis Faktörü Service Factor Service facteur	S <sub>f</sub> = 1 S <sub>f</sub> = 1 S <sub>f</sub> = 1	P <sub>1</sub>	n <sub>2</sub>	i	M <sub>2</sub>	F <sub>Q1</sub>	F <sub>Q10</sub>	Tip Type					
		GÜÇ Power Puissance [kW]	Çıkış Devri Output Speeds Vitesse de sortie [r.p.m] (n <sub>1</sub> =1400rpm)	Tahvil Ratio Rapport de réduction	Çıkış Momenti Output Torque Couple de sortie [Nm]	Rad. Yük Over Loads Charges radiales [N]	Rad. Yük Over Loads Charges radiales [N]						
18000 Nm	0,23	0,11	12403	18000	1550	110000	YP YPF	153 İR 83	149 150	868 908			
	0,24	0,11	12216	18000	1550	110000							
	0,26	0,13	11198	18000	1550	110000							
	0,26	0,13	11007	18000	1550	110000							
	0,29	0,14	9888	18000	1550	110000							
	0,30	0,14	9659	18000	1550	110000							
	0,35	0,17	8268	18000	1550	110000							
	0,39	0,19	7427	18000	1550	110000							
	0,39	0,19	7375	18000	1550	110000							
	0,43	0,21	6672	18000	1550	110000							
	0,49	0,24	5854	18000	1550	110000							
	0,55	0,27	5225	18000	1550	110000							
	0,68	0,33	4227	18000	1550	110000							
	0,83	0,40	3471	18000	1550	110000							
	0,94	0,46	3062	18000	1550	110000							
	1,0	0,50	2779	18000	1550	110000							
	1,4	0,67	2104	18000	1550	110000							
	1,6	0,80	1758	18000	1550	110000							
	0,30	0,14	9721	18000	2500	110000	YP YPF	153 İR 93	151 152	886 926			
	0,33	0,16	8671	18000	2500	110000							
	0,37	0,18	7757	18000	2500	110000							
	0,41	0,20	6990	18000	2500	110000							
	0,43	0,21	6729	18000	2500	110000							
	0,52	0,25	5510	18000	2500	110000							
	0,59	0,28	4917	18000	2500	110000							
	0,60	0,29	4823	18000	2500	110000							
	0,65	0,32	4413	18000	2500	110000							
	0,67	0,33	4303	18000	2500	110000							
	0,73	0,35	3978	18000	2500	110000							
	0,75	0,36	3849	18000	2500	110000							
	0,83	0,40	3500	18000	2500	110000							
	0,92	0,45	3131	18000	2500	110000							
	1,0	0,50	2821	18000	2500	110000							
	1,1	0,55	2534	18000	2500	110000							
	1,3	0,63	2224	18000	2500	110000							
	1,2	0,60	2344	18000	2500	110000							
	1,4	0,68	2066	18000	2500	110000							
	1,5	0,76	1843	18000	2500	110000							
	1,7	0,85	1648	18000	2500	110000							
	1,9	0,94	1485	18000	2500	110000							
	2,1	1,0	1334	18000	2500	110000	YP YPF	153 İR 92	151 152	886 926			
	2,4	1,2	1171	18000	2500	110000							
2,7	1,3	1045	18000	2500	110000								
3,1	1,5	931	18000	2500	110000								
3,3	1,6	863	18000	2500	110000								
3,8	1,8	757	18000	2500	110000								
4,2	2,1	676	18000	2500	110000								
4,7	2,3	607	18000	2500	110000								
4,8	2,4	584,89	18000	2500	110000								
5,3	2,7	528,04	18000	2500	110000	YP YPF					154	147 148	879 919
6,2	3,1	455,48	18000	2500	110000								
7,2	3,6	389,89	18000	2500	110000								
8,1	4,0	347,80	18000	2500	110000								
9,0	4,5	311,14	18000	2500	110000								
10,0	5,0	280,35	18000	2500	110000								





Servis Faktörü Service Factor Service facteur	S <sub>f</sub> = 1 S <sub>f</sub> = 1 S <sub>f</sub> = 1	P <sub>1</sub>	n <sub>2</sub>	i	M <sub>2</sub>	F <sub>Q1</sub>	F <sub>Q10</sub>	Tip Type			
		GÜÇ Power Puissance [kW]	Çıkış Devri Output Speeds Vitesse de sortie [r.p.m] (n <sub>1</sub> =1400rpm)	Tahvil Ratio Rapport de réduction	Çıkış Momenti Output Torque Couple de sortie [Nm]	Rad. Yük Over Loads Charges radiales [N]	Rad. Yük Over Loads Charges radiales [N]				
<b>18000 Nm</b>		11,1	5,6	251,85	18000	2500	110000	<b>YP YPF</b>	<b>154</b>	147 148	879 919
		12,1	6,0	232,41	18000	2500	110000				
		13,4	6,7	209,40	18000	2500	110000				
		14,9	7,4	188,12	18000	2500	110000				
		17,0	8,5	165,06	18000	2500	110000				
		19,0	9,5	147,32	18000	2500	110000				
		10,6	5,4	259,58	18000	5250	110000	<b>YP YPF</b>	<b>153</b>	145 146	861 901
		11,8	6,0	233,55	18000	5250	110000				
		13,1	6,7	210,26	18000	5250	110000				
		14,5	7,3	190,57	18000	5250	110000				
		16,5	8,3	167,80	18000	5250	110000				
		18,4	9,3	150,40	18000	5250	110000				
		20,3	10	135,78	18000	5250	110000				
		23,6	12	117,12	18000	5250	110000				
		27,5	14	100,26	18000	5250	110000				
		30,9	16	89,43	18000	5250	110000				
		34,5	17	80,01	18000	5250	110000				
		38,3	19	72,09	18000	5250	110000				
		42,6	22	64,76	18000	5250	110000				
		48,6	25	56,82	18000	5250	110000				
		54,4	28	50,72	18000	5250	110000				
		60,7	31	45,52	18000	5250	110000				
		67,3	34	41,03	18000	5250	110000				
		74,4	38	37,13	18000	5250	110000				
		82,0	42	33,69	18000	5250	110000				
		90,2	46	30,65	18000	5250	110000				
		108	55	25,51	18000	5250	110000				
		130	66	21,32	18000	5250	110000				
		96,2	50	28,27	18000	5250	110000	<b>YP YPF</b>	<b>152</b>	145 146	851 891
		112	58	24,20	18000	5250	110000				
	126	65	21,65	18000	5250	110000					
	139	72	19,51	18000	5250	110000					
	154	79	17,68	18000	5250	110000					
	169	87	16,11	18000	5250	110000					
	185	95	14,74	18000	5250	110000					
	201	103	13,53	18000	5250	110000					
	236	122	11,52	18000	5250	110000					
	275	142	9,89	18000	5250	110000					



Servis Faktörü Service Factor Service facteur	S <sub>f</sub> =1 S <sub>f</sub> =1 S <sub>f</sub> =1	P <sub>1</sub>	n <sub>2</sub>	i	M <sub>2</sub>	F <sub>Q1</sub>	F <sub>Q10</sub>	Tip Type			
		GÜÇ Power Puissance [kW]	Çıkış Devri Output Speeds Vitesse de sortie [r.p.m] (n <sub>1</sub> =900rpm)	Tahvil Ratio Rapport de réduction	Çıkış Momenti Output Torque Couple de sortie [Nm]	Rad. Yük Over Loads Charges radiales [N]	Rad. Yük Over Loads Charges radiales [N]				
<b>200 Nm</b>	0,17	7,6	119,07	200	390	4500	YP YPF	53	99 100	18 20	
	0,19	8,6	104,31	200	390	4500					
	0,21	9,5	94,78	200	390	4500					
<b>400 Nm</b>	0,21	4,7	190,17	400	475	7000	YP YPF	63	103 104	32 34	
	0,22	5,1	177,47	400	475	7000					
	0,24	5,4	166,10	400	475	7000					
	0,25	5,7	157,69	400	475	7000					
	0,30	6,9	130,52	400	475	7000					
	0,32	7,4	121,67	400	475	7000					
	0,37	8,5	105,48	400	475	7000					
<b>800 Nm</b>	0,37	4,2	212,23	800	590	13500	YP YPF	73	107 108	53 57	
	0,40	4,5	198,05	800	590	13500					
	0,43	4,9	185,37	800	590	13500					
	0,48	5,5	164,46	800	590	13500					
	0,54	6,2	145,66	800	590	13500					
	0,61	7,0	129,23	800	590	13500					
<b>1500 Nm</b>	0,61	3,7	242,30	1500	550	17250	YP YPF	83	113 114	83 89	
	0,71	4,3	209,47	1500	550	17250					
	0,73	4,5	201,75	1500	550	17250					
	0,85	5,2	174,42	1500	550	17250					
<b>3000 Nm</b>	1,0	3,1	285,83	3000	980	25000	YP YPF	93	119 120	115 118	
	1,2	3,6	252,35	3000	980	25000					
	1,3	3,8	235,39	3000	980	25000					
	1,3	4,1	222,00	3000	980	25000					
	1,4	4,2	213,04	3000	980	25000					
	1,5	4,5	198,72	3000	980	25000					
<b>4300 Nm</b>	1,6	3,3	270,11	4300	2500	30000	YP YPF	103	125 126	188 208	
	1,7	3,6	251,95	4300	2500	30000					
	1,9	4,1	221,37	4300	2500	30000					
	2,2	4,6	196,61	4300	2500	30000					
	2,3	5,0	180,75	4300	2500	30000					
	2,6	5,6	160,54	4300	2500	30000					
<b>7800 Nm</b>	3,1	3,6	249,87	7800	3750	61000	YP YPF	123	131 132	287 317	
	3,5	4,1	219,68	7800	3750	61000					
	3,9	4,6	195,24	7800	3750	61000					
	4,4	5,1	175,05	7800	3750	61000					
	6,0	4,5	198,33	12000	3750	75000					
<b>12000 Nm</b>	6,6	5,1	178,04	12000	3750	75000	YP YPF	143	137 138	516 551	
	7,3	5,6	161,00	12000	3750	75000					
	8,8	6,7	134,47	12000	3750	75000					
	10,0	7,6	118,33	12000	3750	75000					
	6,8	3,5	259,58	18000	5250	110000					
<b>18000 Nm</b>	7,6	3,9	233,55	18000	5250	110000	YP YPF	153	145 146	861 901	
	8,4	4,3	210,26	18000	5250	110000					
	9,3	4,7	190,57	18000	5250	110000					
	10,6	5,4	167,80	18000	5250	110000					
	11,8	6,0	150,40	18000	5250	110000					
	13,1	6,6	135,78	18000	5250	110000					
	15,2	7,7	117,12	18000	5250	110000					
	17,7	9,0	100,26	18000	5250	110000					
	19,8	10	89,43	18000	5250	110000					
	22,2	11	80,01	18000	5250	110000					
	24,6	12	72,09	18000	5250	110000					
	27,4	14	64,76	18000	5250	110000					



Servis Faktörü Service Factor Service facteur	S <sub>f</sub> =1 S <sub>f</sub> =1 S <sub>f</sub> =1	P <sub>1</sub>	n <sub>2</sub>	i	M <sub>2</sub>	F <sub>Q1</sub>	F <sub>Q10</sub>	Tip			
		GÜÇ Power Puissance [kW]	Çıkış Devri Output Speeds Vitesse de sortie [r.p.m] (n <sub>1</sub> =700rpm)	Tahvil Ratio Rapport de réduction	Çıkış Momenti Output Torque Couple de sortie [Nm]	Rad. Yük Over Loads Charges radiales [N]	Rad. Yük Over Loads Charges radiales [N]	YP YPF			
<b>3000 Nm</b>		0,80	2,4	285,83	3000	1550	25000	YP YPF	93	119	115
		0,91	2,8	252,35	3000	1550	25000			120	118
		0,98	3,0	235,39	3000	1550	25000				
<b>4300 Nm</b>		1,2	2,6	270,11	4300	2500	30000	YP YPF	103	125	188
		1,3	2,8	251,95	4300	2500	30000			126	208
		1,5	3,2	221,37	4300	2500	30000				
		1,7	3,6	196,61	4300	2500	30000				
<b>7800 Nm</b>		2,4	2,8	249,87	7800	3750	61000	YP YPF	123	131	287
		2,7	3,2	219,68	7800	3750	61000			132	317
		3,1	3,6	195,24	7800	3750	61000				
<b>12000 Nm</b>		5,2	3,9	178,04	12000	3750	75000	YP YPF	143	137	516
		5,7	4,3	161,00	12000	3750	75000			138	551
		6,8	5,2	134,47	12000	3750	75000				
		7,8	5,9	118,33	12000	3750	75000				
<b>18000 Nm</b>		5,3	2,7	259,58	18000	5250	11000	YP YPF	153	145	861
		5,9	3,0	233,55	18000	5250	11000			146	901
		6,6	3,3	210,26	18000	5250	11000				
		7,2	3,7	190,57	18000	5250	11000				

## YP Serisi Redüktörler Ölçü Sayfaları

---

Dimensions Pages  
*Dimensions*





**YPM 52  
YPM 53**

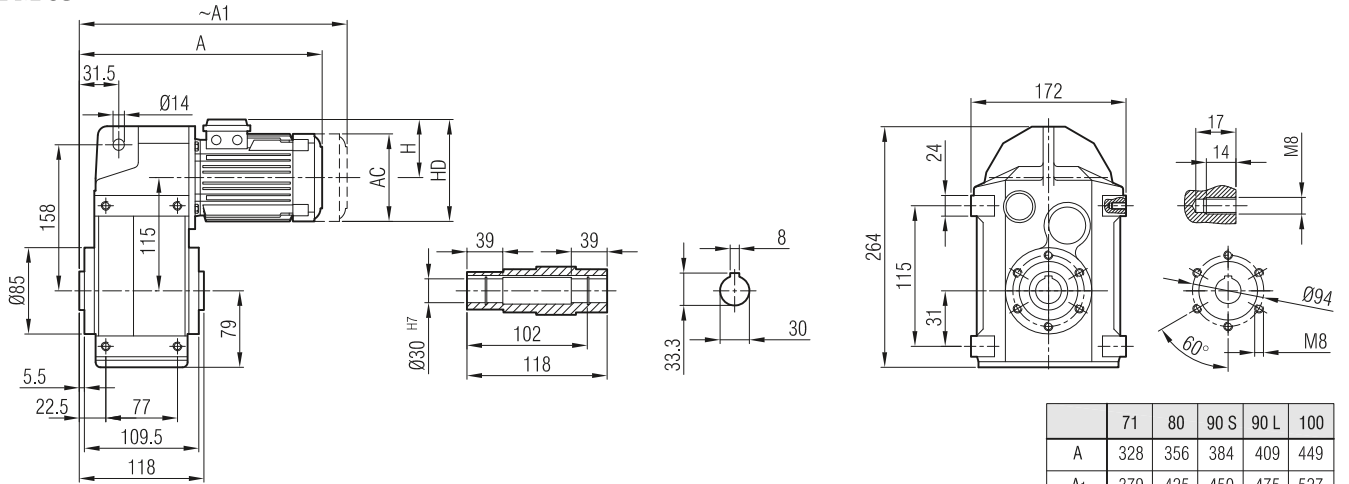

	71	80	90 S	90 L	100
A	328	356	384	409	449
A <sub>1</sub>	379	425	450	475	527
H	111	118	126	126	134
HD	182	198	216	216	234
AC	138	156	176	176	194

**YP 52  
YP 53**

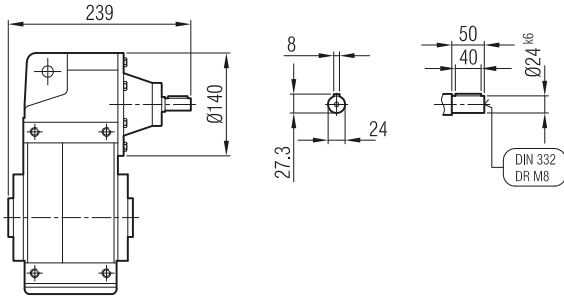

"A<sub>1</sub>" Ölçüsü Frenli Motorlar içindir.  
Dimension "A<sub>1</sub>" is for motors with brake.  
Le dimensions "A<sub>1</sub>" correspondent aux moteurs équipés de freins.

**YPPM 52  
YPPM 53**



	63/B5	71/B5	80/B5	90 S/B5	90 L/B5	100/B5
A	342	377	400	415	440	486
A <sub>1</sub>	398	428	469	481	506	564
H	97	111	118	126	126	134
HD	160	182	198	216	216	234
AC	121	138	156	176	176	194

"A<sub>1</sub>" Ölçüsü Frenli Motorlar içindir.  
Dimension "A<sub>1</sub>" is for motors with brake.  
Le dimensions "A<sub>1</sub>" correspondent aux moteurs équipés de freins.

**YPP 52  
YPP 53**

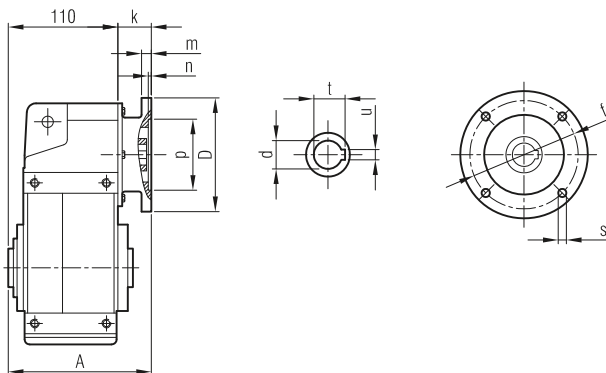

	A	Øp	Øf	ØD	s	k	m	n	Ød	t	u
63/B5	146	95	115	140	M8	35.5	8	4	11	12.8	4
71/B5	154	110	130	160	M8	44	9	4	14	16.3	5
80/B5	156	130	165	200	M10	46	12	5	19	21.8	6
90/B5	156	130	165	200	M10	46	12	5	24	27.3	8
100/B5	170	180	215	250	M12	60	14	5	28	31.3	8





**YPM / YP  
YPPM / YPP ... -SL**

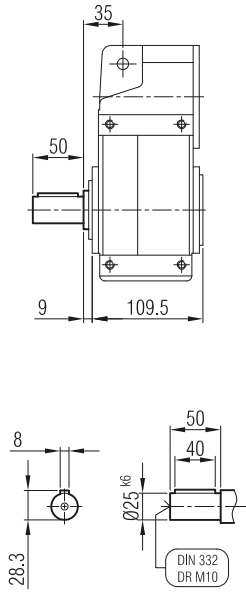

**... -H**

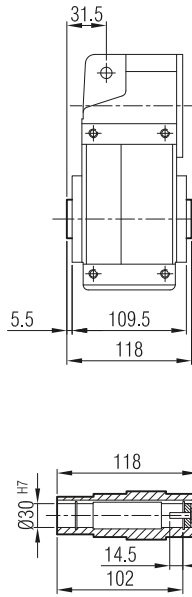

**... -SDL**

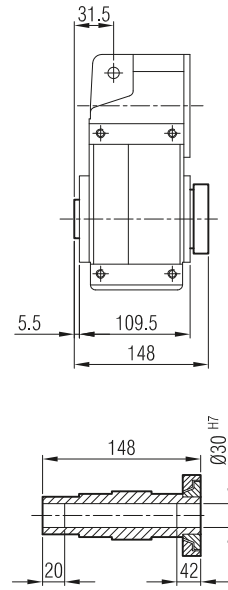

**YPFM / YPF  
YPFPM / YFPF ... -FL -SL**

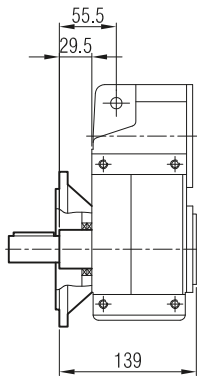

**... -FL**

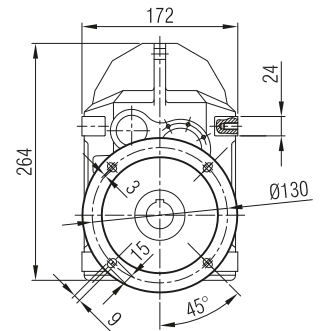
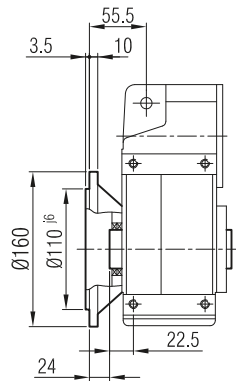

**-TL**

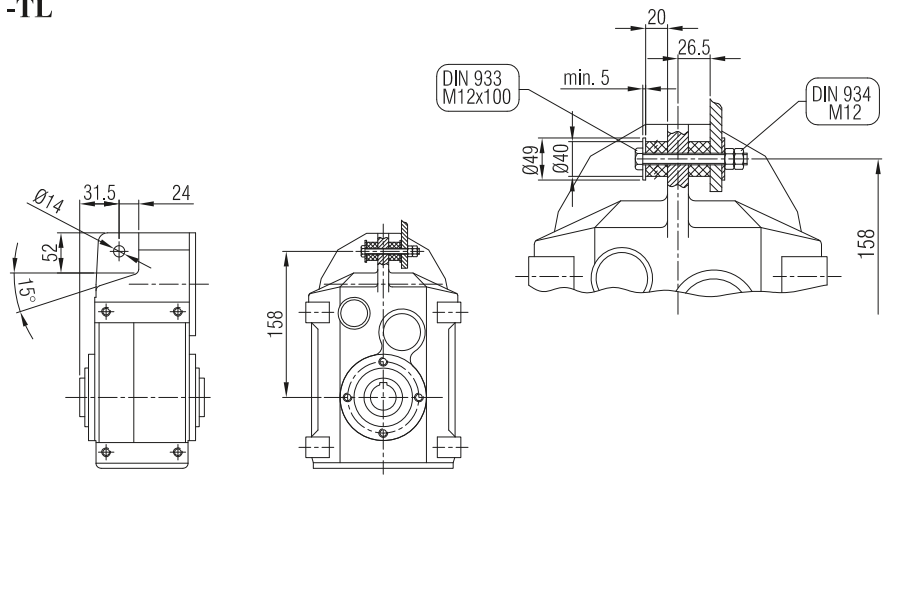

**Klemens Pozisyonları  
Terminal Box Positions  
Klemenskasten Positionen**

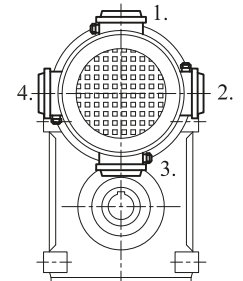



**YPM 52 İR 42**  
**YPM 53 İR 42**

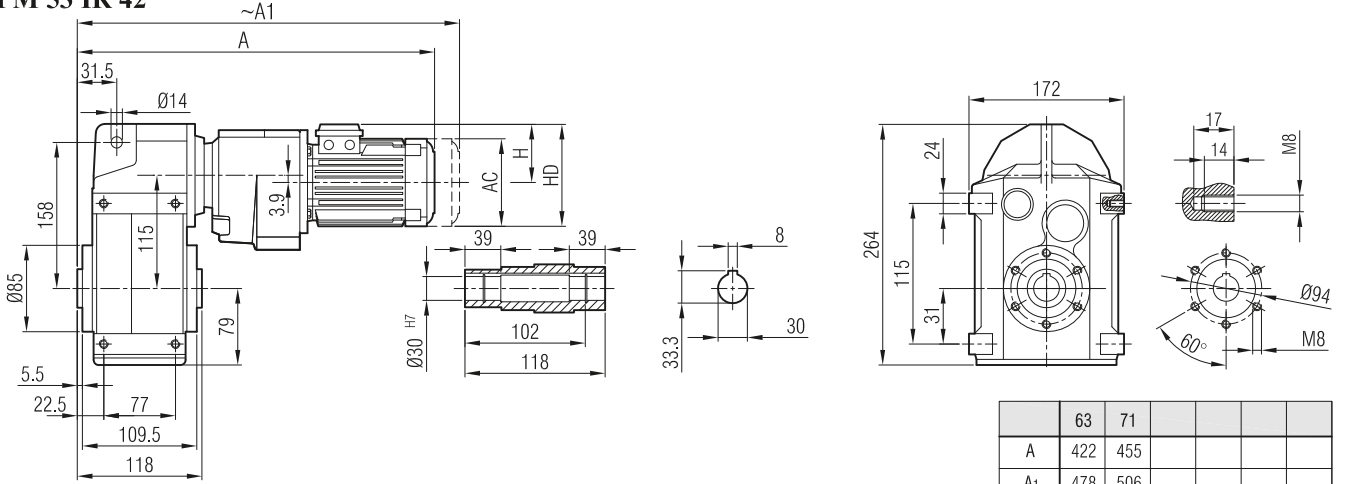

	63	71			
A	422	455			
A <sub>1</sub>	478	506			
H	97	111			
HD	160	182			
AC	121	138			

"A<sub>1</sub>" Ölçüsü Frenli Motorlar içindir.  
Dimension "A<sub>1</sub>" is for motors with brake.  
Le dimensions "A<sub>1</sub>" correspondent aux moteurs équipés de freins.

**YP 52 İR 42 / YP 53 İR 43**  
**YP 53 İR 42 / YP 53 İR 43**

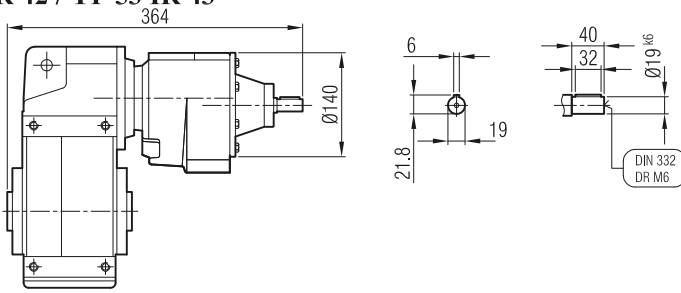

**YPPM 52 İR 42**  
**YPPM 53 İR 42**

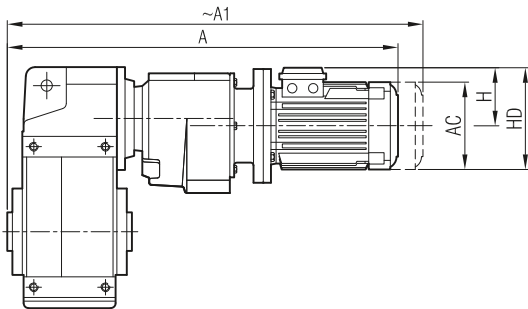

	63/B5	71/B5			
A	467	502			
A <sub>1</sub>	523	553			
H	97	111			
HD	160	182			
AC	121	138			

"A<sub>1</sub>" Ölçüsü Frenli Motorlar içindir.  
Dimension "A<sub>1</sub>" is for motors with brake.  
Le dimensions "A<sub>1</sub>" correspondent aux moteurs équipés de freins.

**YPP 52 İR 42**  
**YPP 53 İR 42**

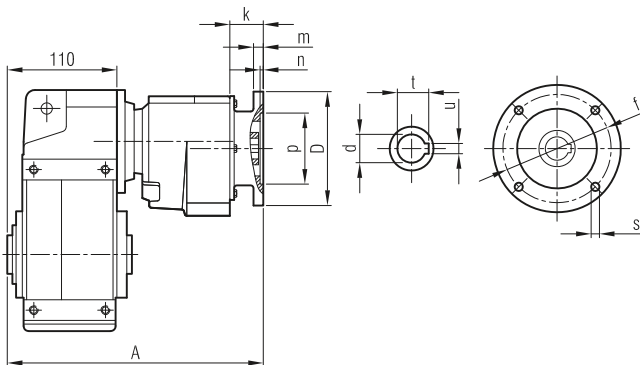

	A	Øp	Øf	ØD	s	k	m	n	Ød	t	u
63/B5	271	95	115	140	M8	35.5	8	4	11	12.8	4
71/B5	279	110	130	160	M8	44	9	4	14	16.3	5



**YPM / YP  
YPPM / YPP**

**... -SL**

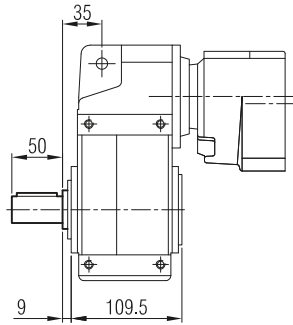

**... -H**

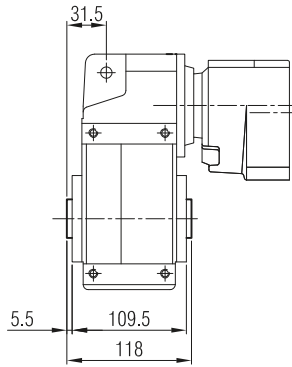

**... -SDL**

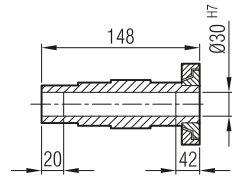
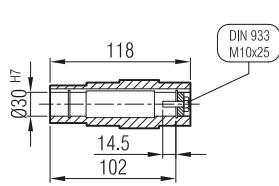
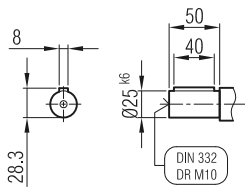
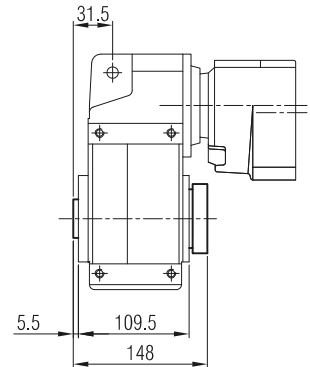

**YPFM / YPF  
YPFPM / YFPF**

**... -FL -SL**

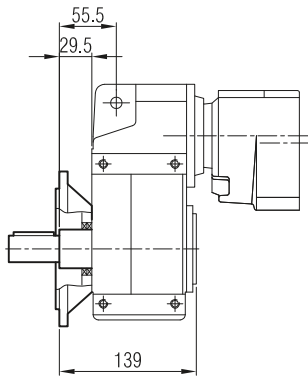

**... -FL**

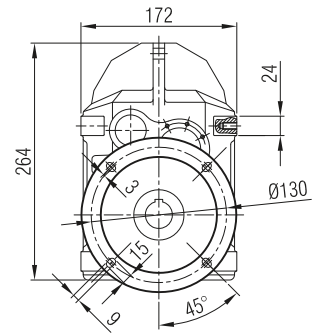
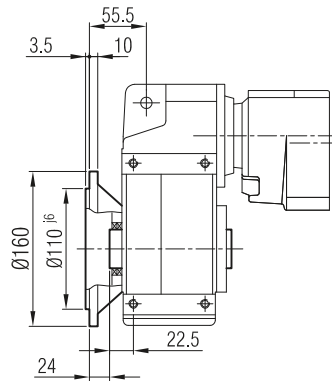

**-TL**

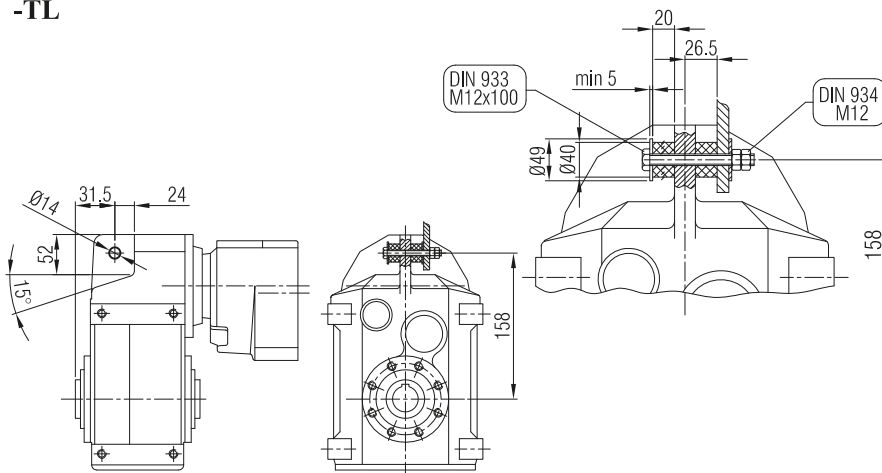

**Klemens Pozisyonları  
Terminal Box Positions  
Klemenskasten Positionen**

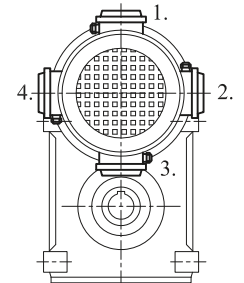



**YPM 62  
YPM 63**

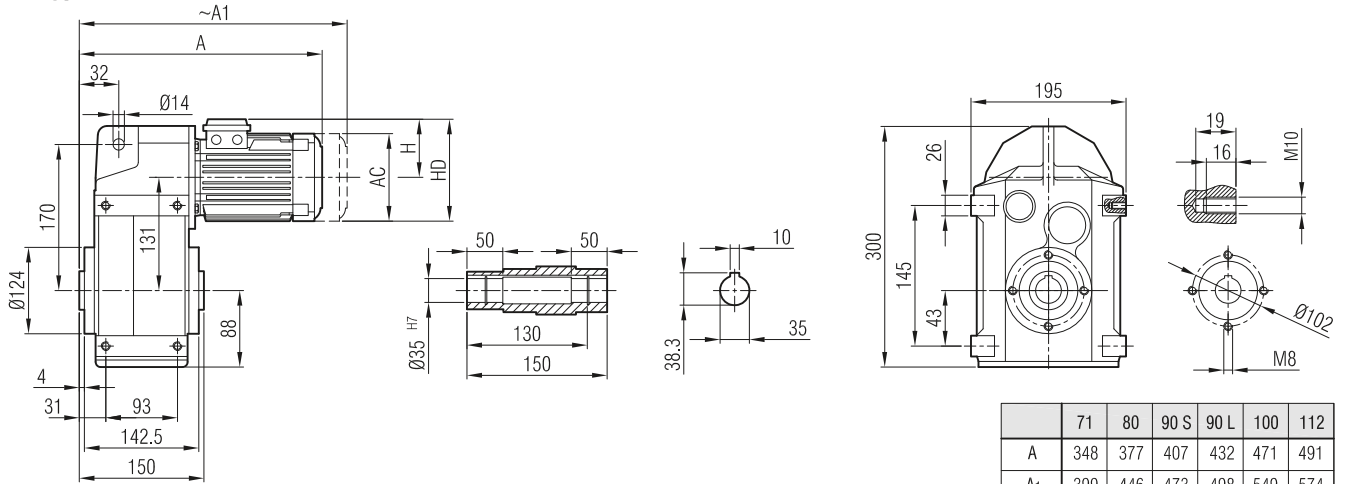

	71	80	90 S	90 L	100	112
A	348	377	407	432	471	491
A <sub>1</sub>	399	446	473	498	549	574
H	111	118	126	126	134	145
HD	182	198	216	216	234	257
AC	138	156	176	176	194	218

"A<sub>1</sub>" Ölçüsü Frenli Motorlar içindir.  
Dimension "A<sub>1</sub>" is for motors with brake.  
Le dimensions "A<sub>1</sub>" correspondent aux moteurs équipés de freins.

**YP 62  
YP 63**

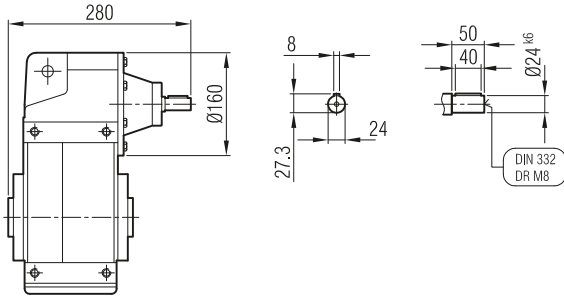

**YPPM 62  
YPPM 63**

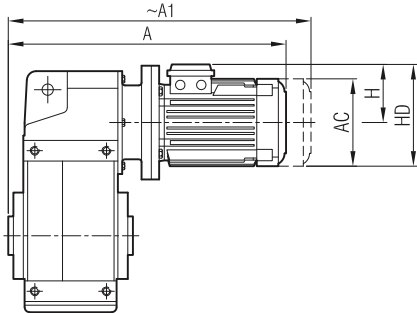

	63/B5	71/B5	80/B5	90 S/B5	90 L/B5	100/B5	112/B5
A	369	405	431	446	471	516	536
A <sub>1</sub>	425	456	500	512	537	594	619
H	97	111	118	126	126	134	145
HD	160	182	198	216	216	234	257
AC	121	138	156	176	176	194	218

"A<sub>1</sub>" Ölçüsü Frenli Motorlar içindir.  
Dimension "A<sub>1</sub>" is for motors with brake.  
Le dimensions "A<sub>1</sub>" correspondent aux moteurs équipés de freins.

**YPP 62  
YPP 63**

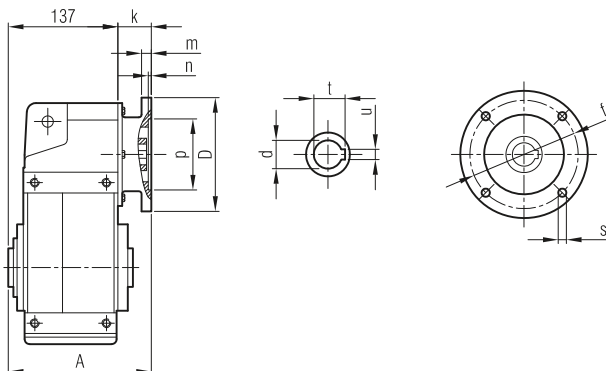

	A	Øp	Øf	ØD	s	k	m	n	Ød	t	u
63/B5	173	95	115	140	M8	35.5	8	4	11	12.8	4
71/B5	182	110	130	160	M8	45	9	4	14	16.3	5
80/B5	187	130	165	200	M10	50	12	5	19	21.8	6
90/B5	187	130	165	200	M10	50	12	5	24	27.3	8
100/B5	200	180	215	250	M12	63	14	5	28	31.3	8
112/B5	200	180	215	250	M12	63	14	5	28	31.3	8



**YPM / YP  
YPPM / YPP**

**... -SL**

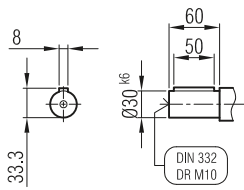
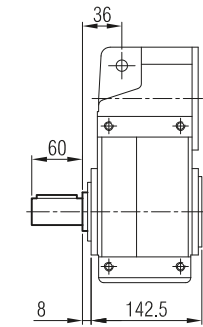

**... -H**

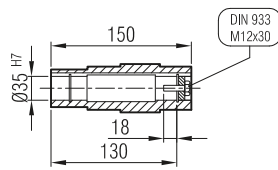
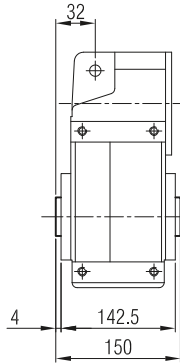

**... -SDL**

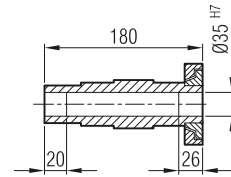
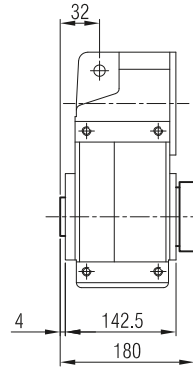

**YPFM / YPF  
YPPFM / YPPF**

**... -FL -SL**

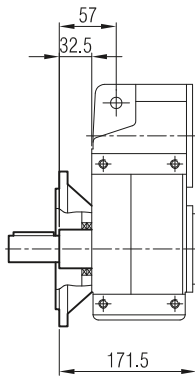

**... -FL**

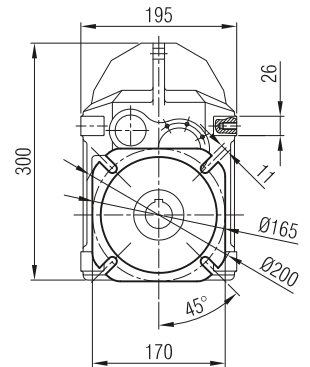
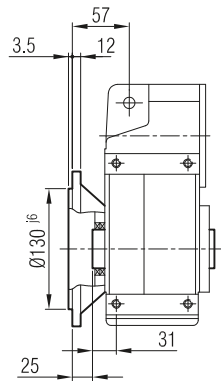

**-TL**

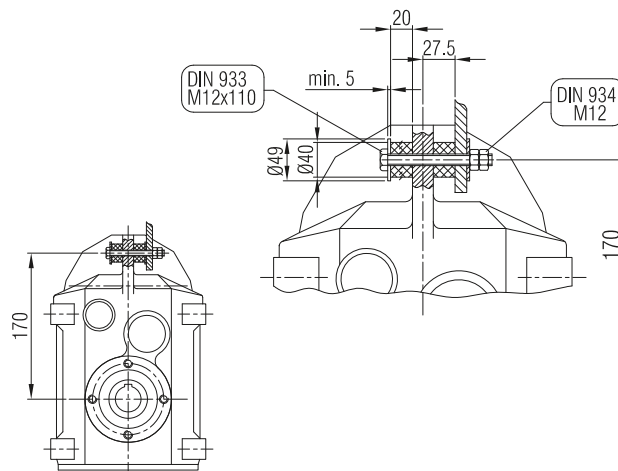
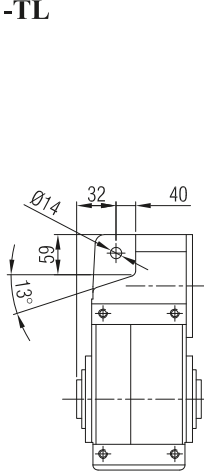

**Klemens Pozisyonları**  
Terminal Box Positions  
Klemenskasten Positionen

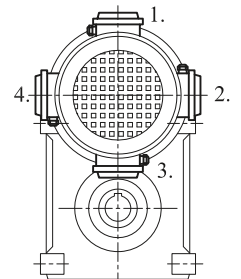

80, 90, 100, 112  
B5 Tip/Type/Typ

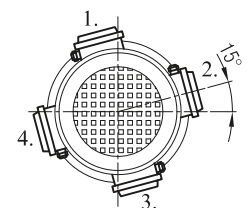

71 B5 Tip/Type/Typ



**YPM 62 İR 42**  
**YPM 63 İR 42**

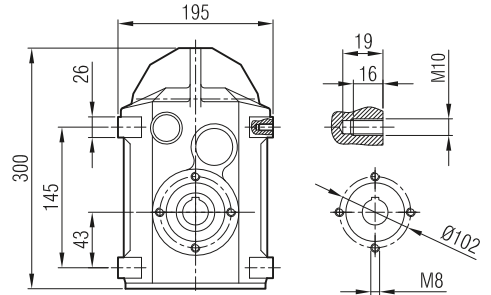
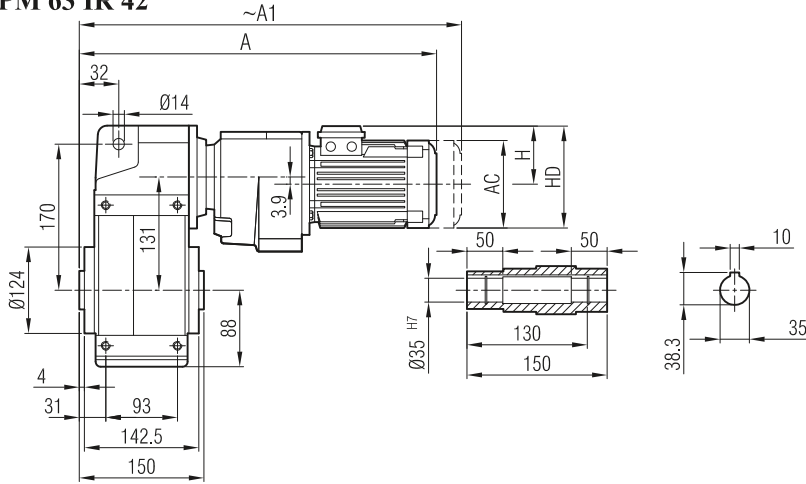

	63	71		
A	449	482		
A <sub>1</sub>	505	533		
H	97	111		
HD	160	182		
AC	121	138		

**YP 62 İR 42 / YP 62 İR 43**  
**YP 63 İR 42 / YP 63 İR 43**

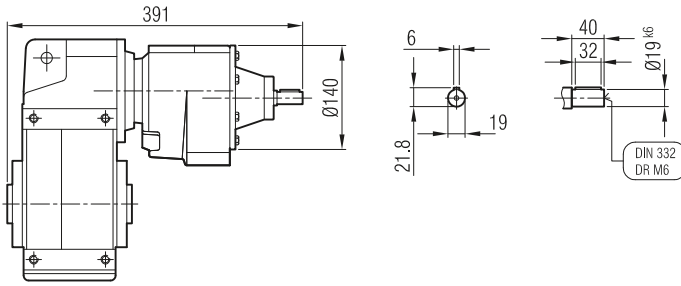

**"A<sub>1</sub>" Ölçüsü Frenli Motorlar içindir.**  
Dimension "A<sub>1</sub>" is for motors with brake.  
Le dimensions "A<sub>1</sub>" correspondent aux moteurs équipés de freins.

**YPPM 62 İR 42**  
**YPPM 63 İR 42**

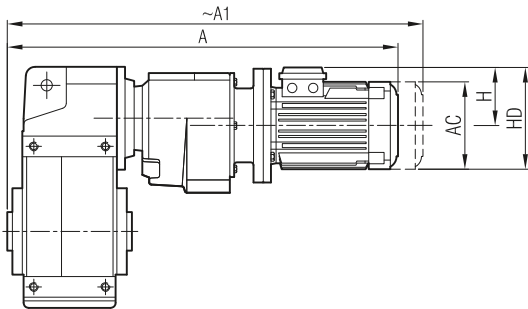

	63/B5	71/B5		
A	494	529		
A <sub>1</sub>	550	580		
H	97	111		
HD	160	182		
AC	121	138		

**"A<sub>1</sub>" Ölçüsü Frenli Motorlar içindir.**  
Dimension "A<sub>1</sub>" is for motors with brake.  
Le dimensions "A<sub>1</sub>" correspondent aux moteurs équipés de freins.

**YPP 62 İR 42**  
**YPP 63 İR 42**

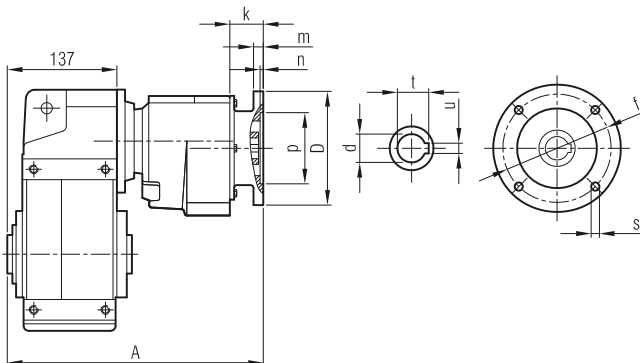

	A	Øp	Øf	ØD	s	k	m	n	Ød	t	u
63/B5	298	95	115	140	M8	35.5	8	4	11	12.8	4
71/B5	306	110	130	160	M8	45	9	4	14	16.3	5



**YPM / YP  
YPPM / YPP**

**... -SL**

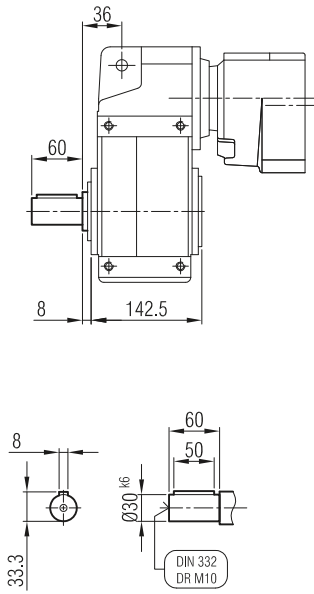

**... -H**

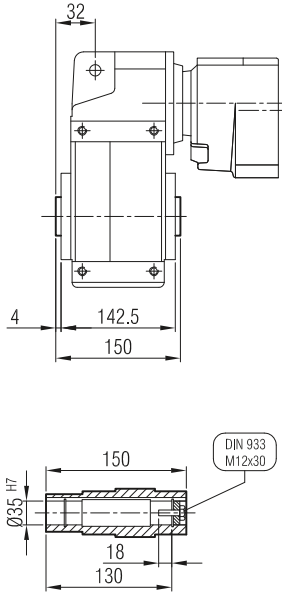

**... -SDL**

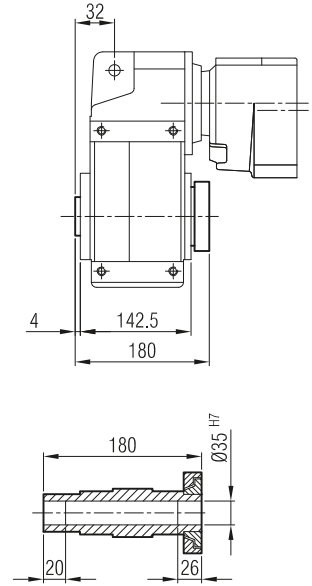

**YPFM / YPF  
YPPFM / YPPF**

**... -FL -SL**

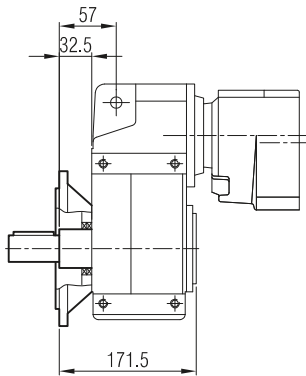

**... -FL**

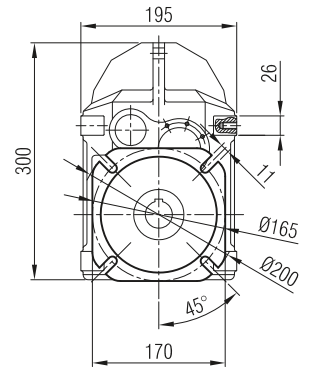
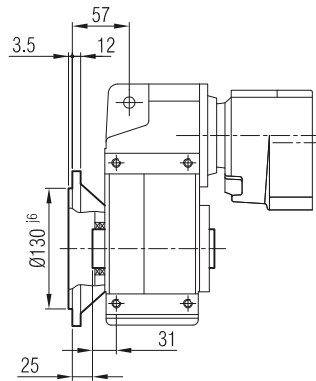

**-TL**

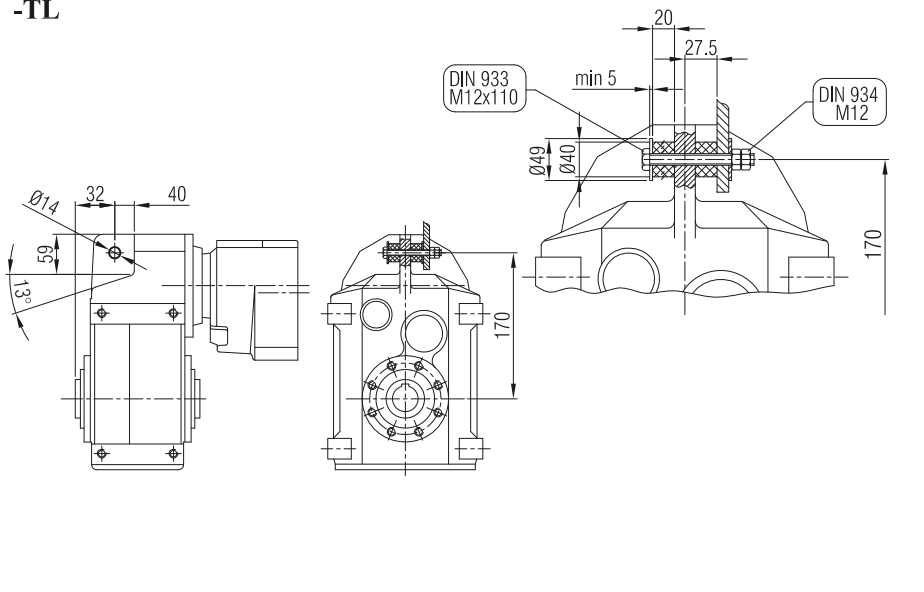

**Klemens Pozisyonları**  
Terminal Box Positions  
Klemenskasten Positionen

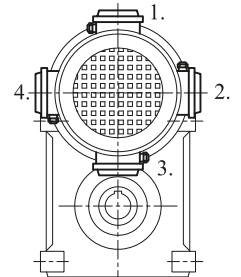

80, 90, 100, 112  
B5 Tip/Type/Typ

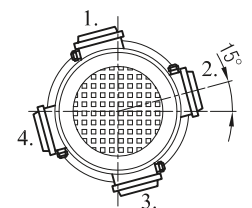

71 B5 Tip/Type/Typ



**YPM 72  
YPM 73**

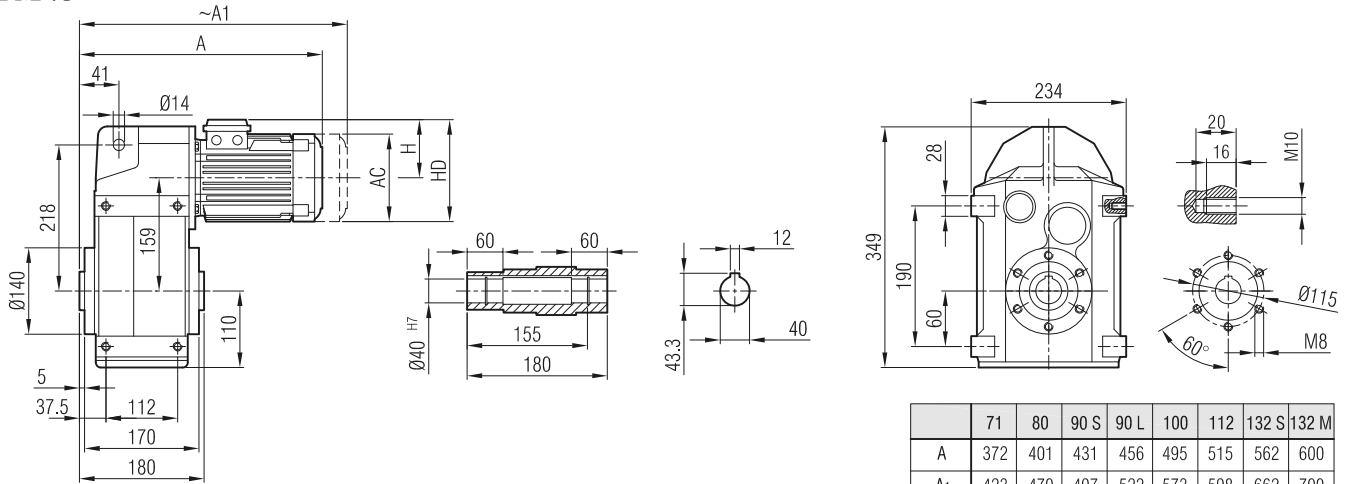

	71	80	90 S	90 L	100	112	132 S	132 M
A	372	401	431	456	495	515	562	600
A <sub>1</sub>	423	470	497	522	573	598	662	700
H	111	118	126	126	134	145	168	168
HD	182	198	216	216	234	257	300	300
AC	138	156	176	176	194	218	257	257

**YP 72  
YP 73**

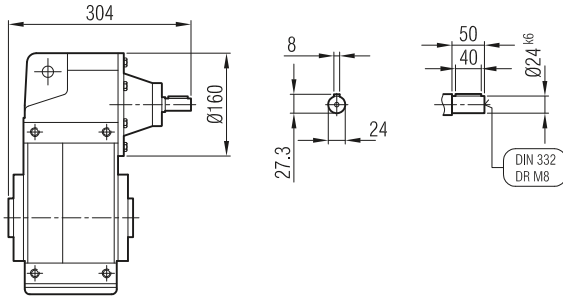

**"A<sub>1</sub>" Ölçüsü Frenli Motorlar içindir.**  
Dimension "A<sub>1</sub>" is for motors with brake.  
Le dimensions "A<sub>1</sub>" correspondent aux moteurs équipés de freins.

**YPPM 72  
YPPM 73**

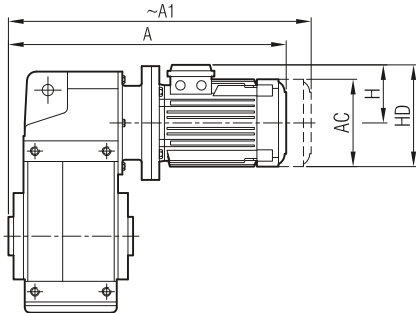

	63/B5	71/B5	80/B5	90 S/B5	90 L/B5	100/ B5	112/ B5	132 S/B5	132 M/B5
A	393	429	455	470	495	540	560	620	658
A <sub>1</sub>	449	480	524	536	561	618	643	720	758
H	97	111	118	126	126	134	145	168	168
HD	160	182	198	216	216	234	257	300	300
AC	121	138	156	176	176	194	218	257	257

**"A<sub>1</sub>" Ölçüsü Frenli Motorlar içindir.**  
Dimension "A<sub>1</sub>" is for motors with brake.  
Le dimensions "A<sub>1</sub>" correspondent aux moteurs équipés de freins.

**YPP 72  
YPP 73**

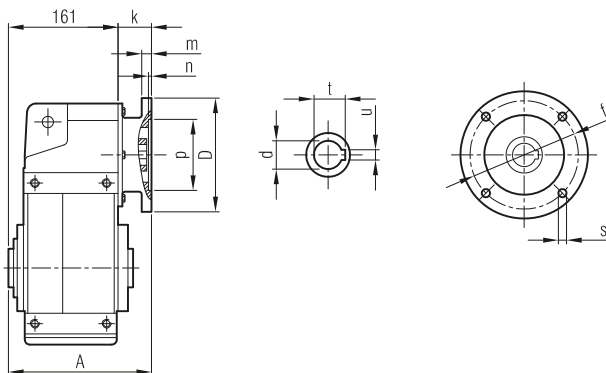

	A	Øp	Øf	ØD	s	k	m	n	Ød	t	u
63/B5	197	95	115	140	M8	35,5	8	4	11	12,8	4
71/B5	206	110	130	160	M8	45	9	4	14	16,3	5
80/B5	211	130	165	200	M10	50	12	5	19	21,8	6
90/B5	211	130	165	200	M10	50	12	5	24	27,3	8
100/B5	224	180	215	250	M12	63	14	5	28	31,3	8
112/B5	224	180	215	250	M12	63	14	5	28	31,3	8
132/B5	240	230	265	300	M12	79	17	5	38	41,3	10





**YPM / YP  
YPPM / YPP ... -SL**

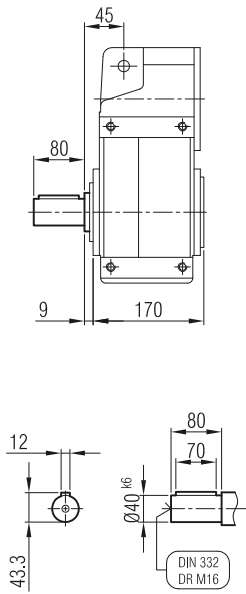

**... -H**

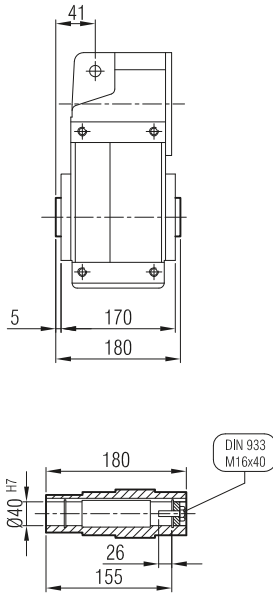

**... -SDL**

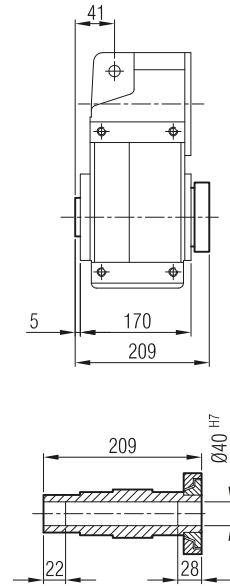

**YPFM / YPF  
YPFPM / YPF ... -FL -SL**

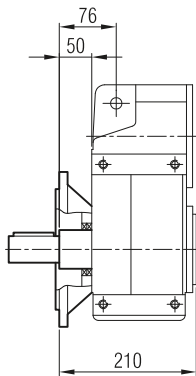

**... -FL**

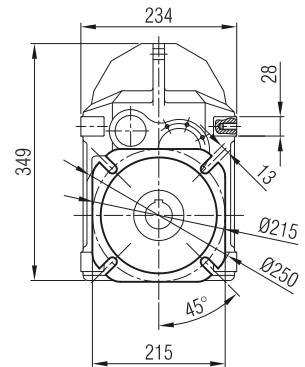
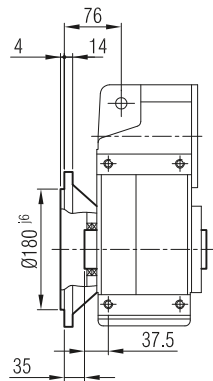

**-TL**

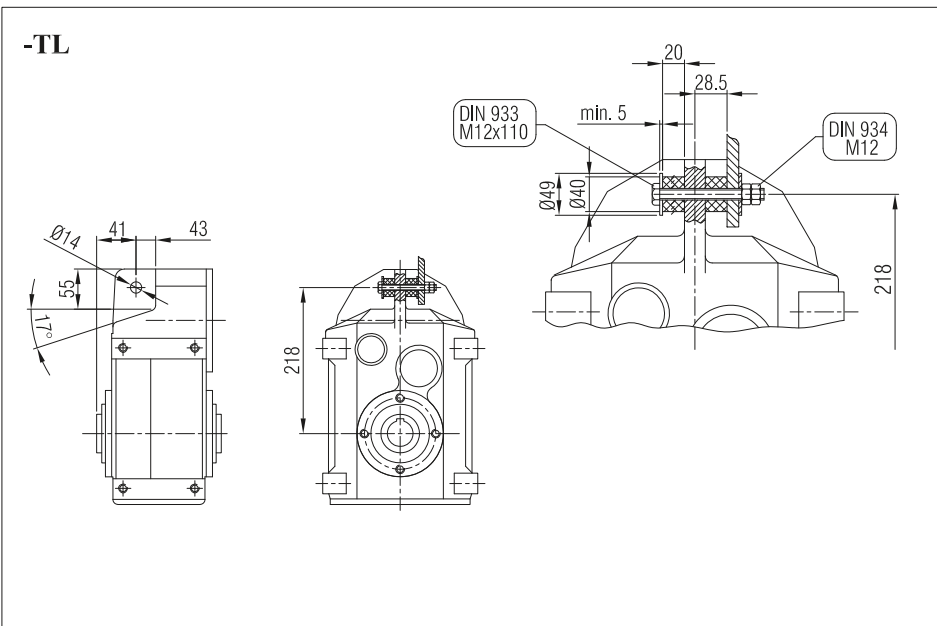

**Klemens Pozisyonları**  
Terminal Box Positions  
Klemenskasten Positionen

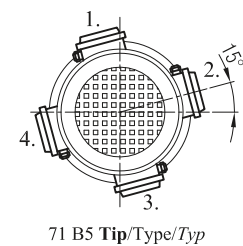
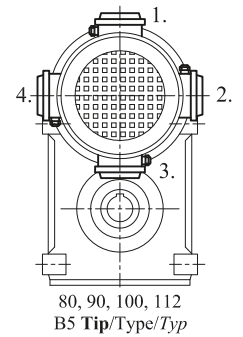



**YPM 74**

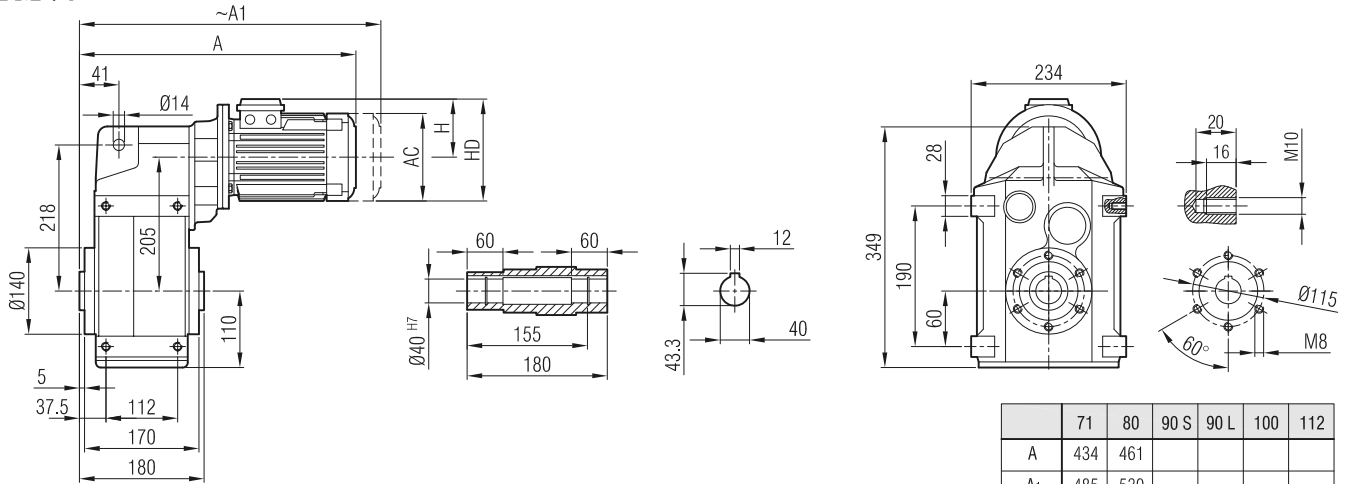

	71	80	90 S	90 L	100	112
A	434	461				
A <sub>1</sub>	485	530				
H	111	118				
HD	182	198				
AC	138	156				

"A<sub>1</sub>" Ölçüsü Frenli Motorlar içindir.  
Dimension "A<sub>1</sub>" is for motors with brake.  
Le dimensions "A<sub>1</sub>" correspondent aux moteurs équipés de freins.

**YP 74**

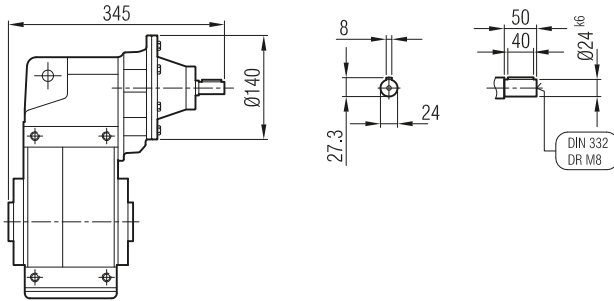

**YPPM 74**

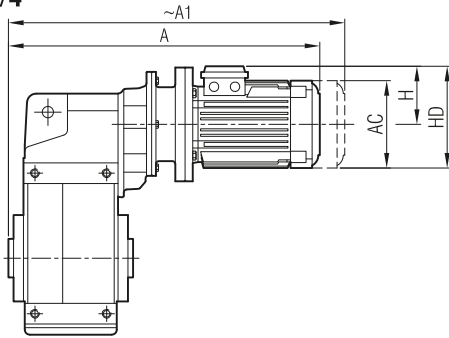

	63/B5	71/B5	80/B5	90 S/B5
A	448	483	506	
A <sub>1</sub>	504	534	575	
H	97	111	118	
HD	160	182	198	
AC	121	138	156	

"A<sub>1</sub>" Ölçüsü Frenli Motorlar içindir.  
Dimension "A<sub>1</sub>" is for motors with brake.  
Le dimensions "A<sub>1</sub>" correspondent aux moteurs équipés de freins.

**YPP 74**

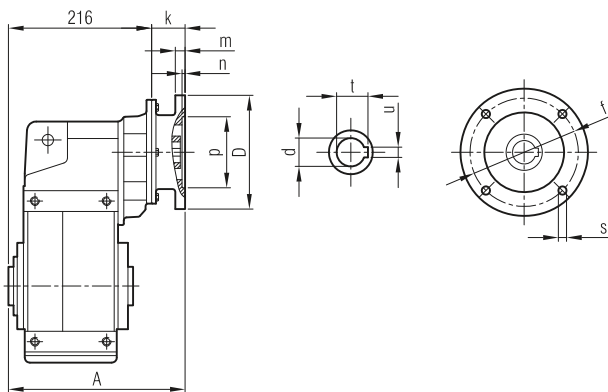

	A	Øp	Øf	ØD	s	k	m	n	Ød	t	u
63/B5	252	95	115	140	M8	35,5	8	4	11	12,8	4
71/B5	260	110	130	160	M8	44	9	4	14	16,3	5
80/B5	262	130	165	200	M10	46	12	5	19	21,8	6



**YPM / YP  
YPPM / YPP ... -SL**

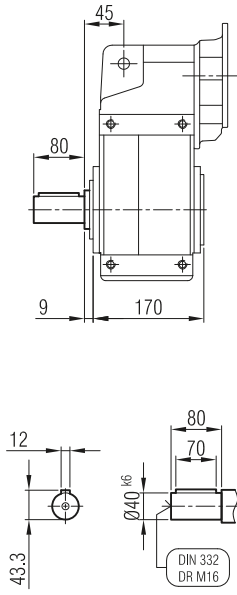

**... -H**

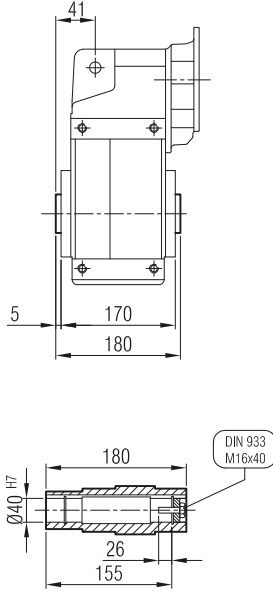

**... -SDL**

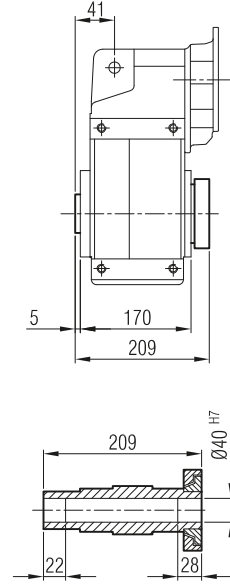

**YPFM / YPF  
YPFPM / YPF ... -FL -SL**

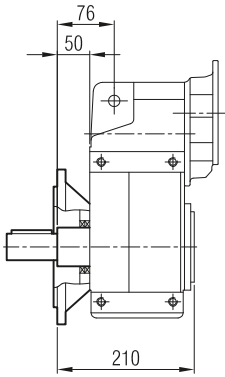

**... -FL**

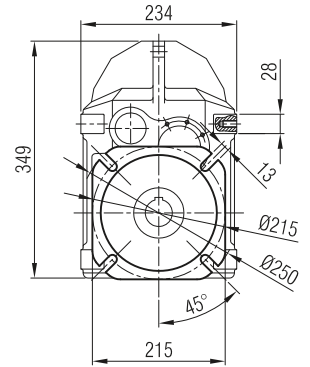
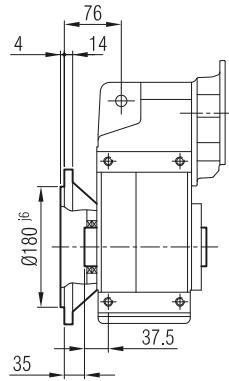

**-TL**

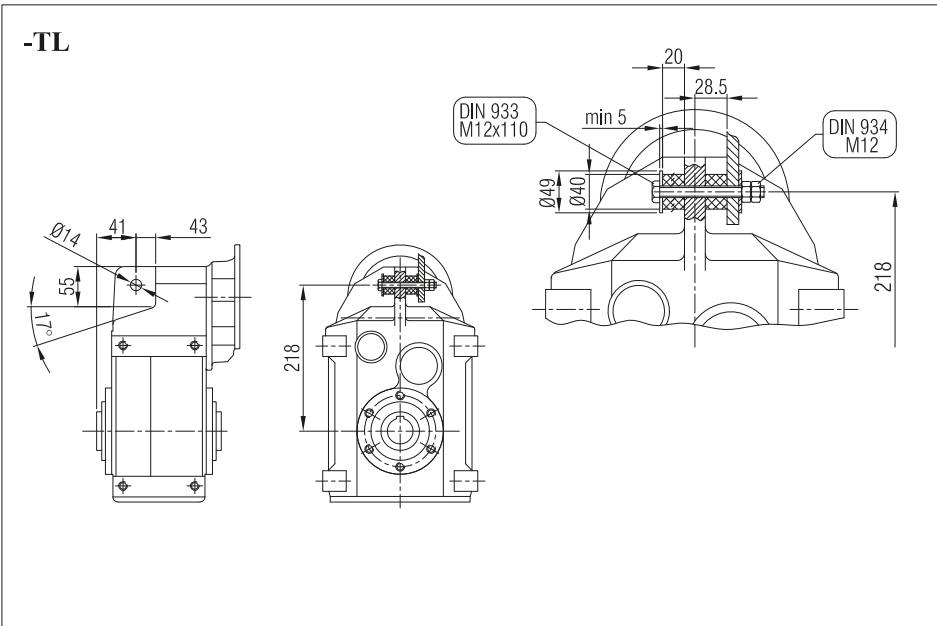

**Klemens Pozisyonları**  
Terminal Box Positions  
Klemenskasten Positionen

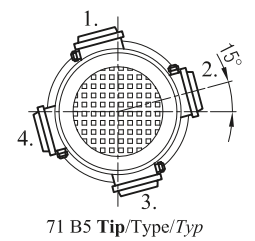
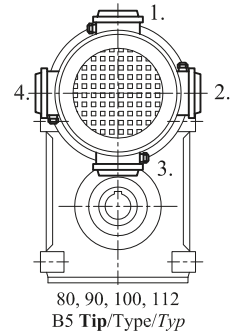



**YPM 72 İR 53**  
**YPM 73 İR 52**

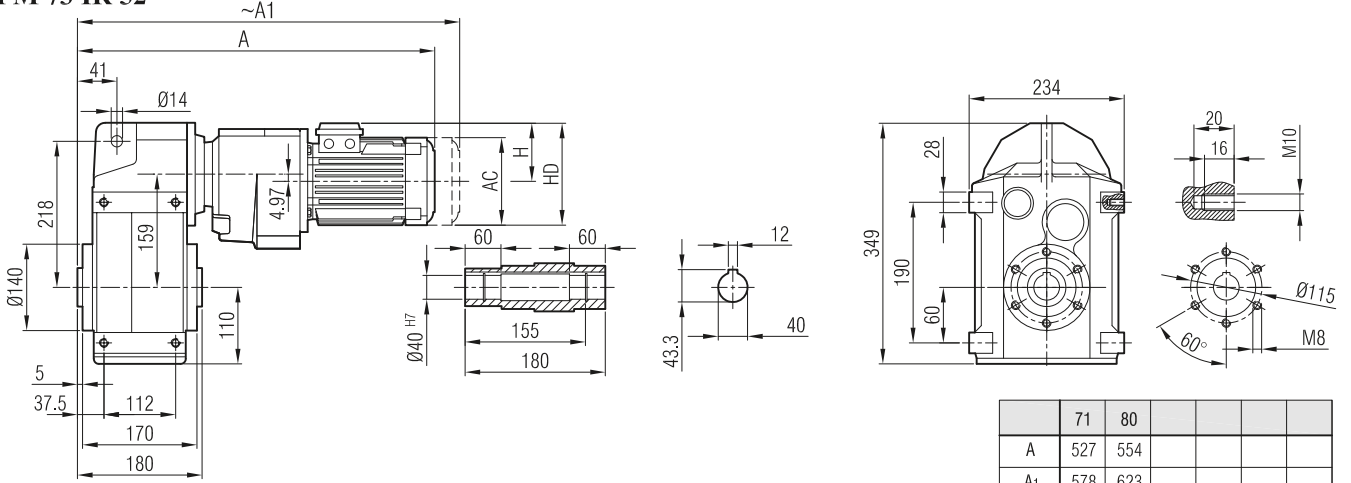

	71	80			
A	527	554			
A <sub>1</sub>	578	623			
H	111	118			
HD	182	198			
AC	138	156			

**YP 72 İR 52 / YP 72 İR 53**  
**YP 73 İR 53 / YP 73 İR 53**

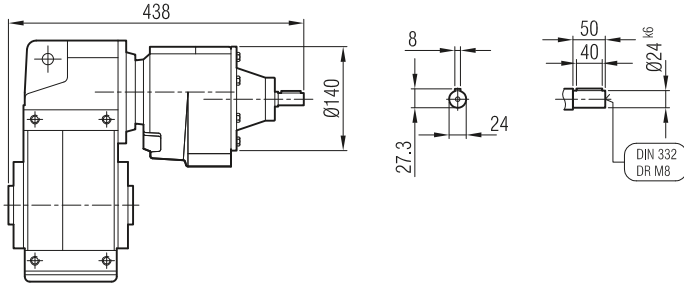

**"A<sub>1</sub>" Ölçüsü Frenli Motorlar içindir.**  
Dimension "A<sub>1</sub>" is for motors with brake.  
Le dimensions "A<sub>1</sub>" correspondent aux moteurs équipés de freins.

**YPPM 72 İR 53**  
**YPPM 73 İR 52**

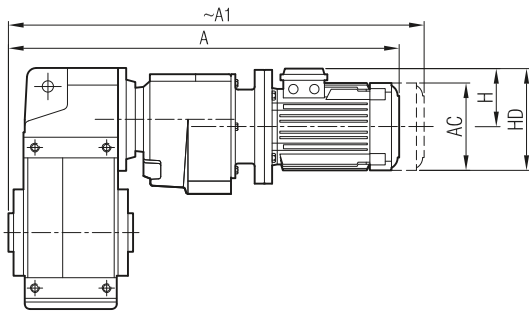

	63/B5	71/B5	80/B5	
A	541	576	599	
A <sub>1</sub>	597	627	668	
H	97	111	118	
HD	160	182	198	
AC	121	138	156	

**"A<sub>1</sub>" Ölçüsü Frenli Motorlar içindir.**  
Dimension "A<sub>1</sub>" is for motors with brake.  
Le dimensions "A<sub>1</sub>" correspondent aux moteurs équipés de freins.

**YPP 72 İR 53**  
**YPP 73 İR 52**

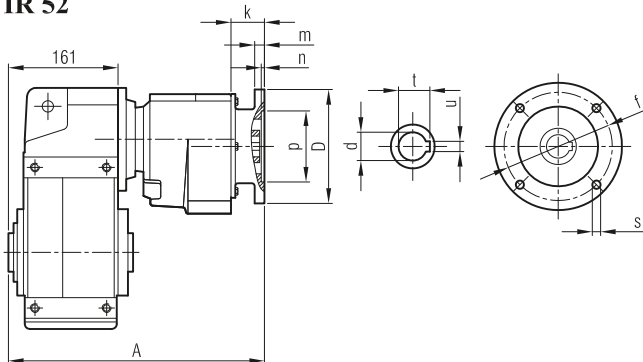

	A	Øp	Øf	ØD	s	k	m	n	Ød	t	u
63/B5	345	95	115	140	M8	35,5	8	4	11	12,8	4
71/B5	353	110	130	160	M8	44	9	4	14	16,3	5
80/B5	355	130	165	200	M10	46	12	5	19	21,8	6



**YPM / YP  
YPPM / YPP**

**... -SL**

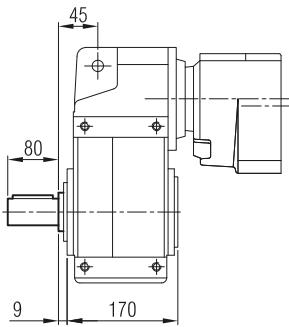

**... -H**

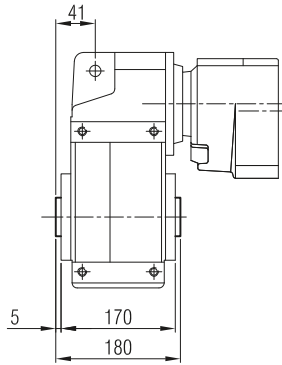

**... -SDL**

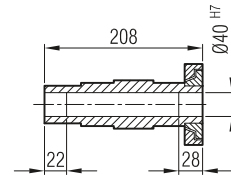
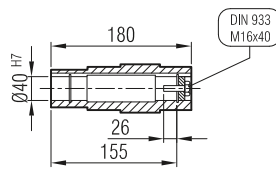
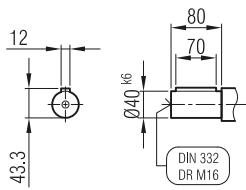
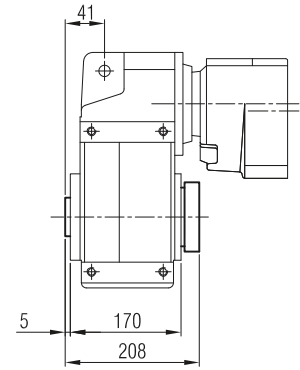

**YPFM / YPF  
YPFPM / YPF**

**... -FL -SL**

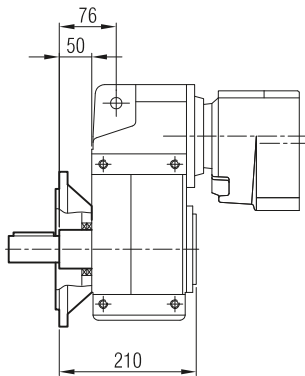

**... -FL**

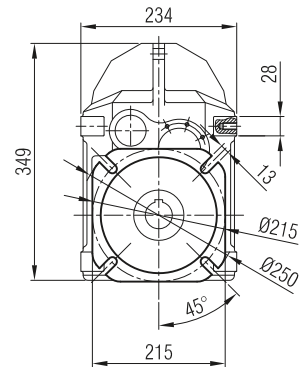
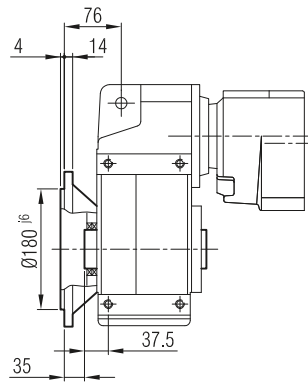

**-TL**

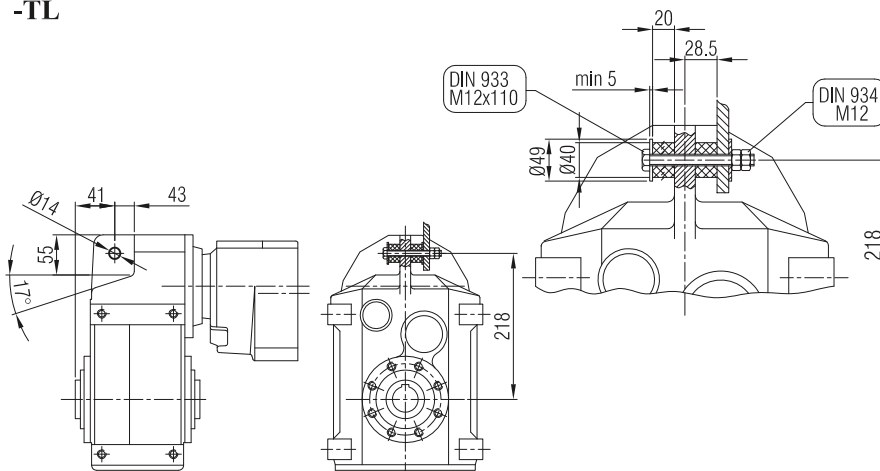

**Klemens Pozisyonları**  
Terminal Box Positions  
Klemenskasten Positionen

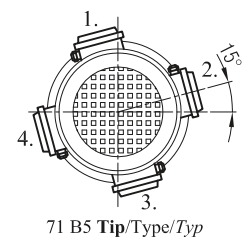
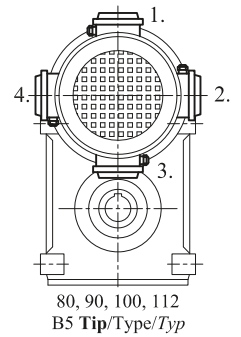



**YPM 82**  
**YPM 83**

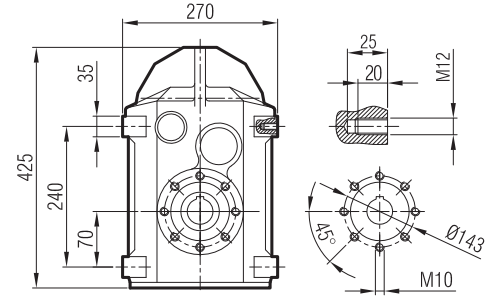
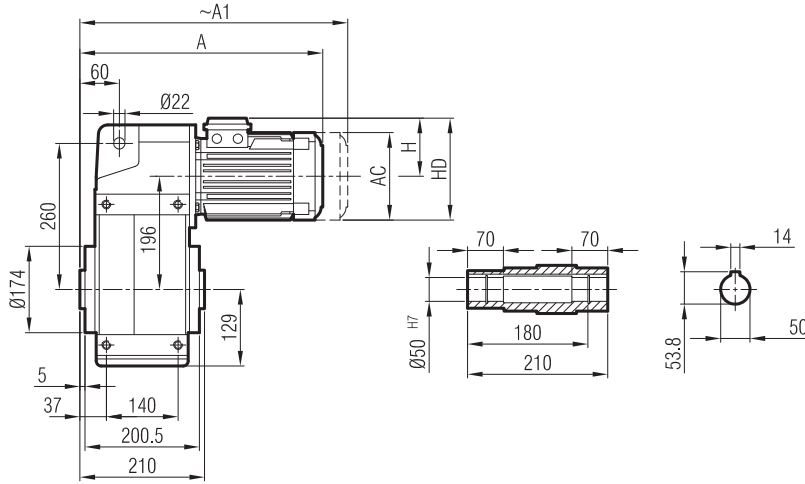

	71	80	90 S	90 L	100	112	132 S	132 M	160 M	160 L
A	394	424	454	479	521	544	591	629	696	767
A <sub>1</sub>	445	493	520	545	599	627	691	729	821	855
H	111	118	126	126	134	145	168	168	220	220
HD	182	198	216	216	234	257	300	300	380	380
AC	138	156	176	176	194	218	257	257	310	310

**YP 82**  
**YP 83**

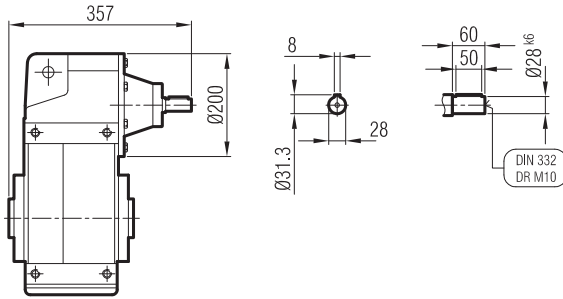

**"A<sub>1</sub>" Ölçüsü Frenli Motorlar içindir.**  
Dimension "A<sub>1</sub>" is for motors with brake.  
*Le dimensions "A<sub>1</sub>" correspondent aux moteurs équipés de freins.*

**YPPM 82**  
**YPPM 83**

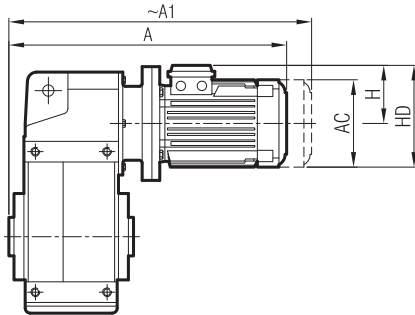

	71/B5	80/B5	90 S/B5	90 L/B5	100/ B5	112/ B5	132 S/B5	132 M/B5	160 M/B5	160 L/B5
A	470	503	519	544	580	600	668	706	796	767
A <sub>1</sub>	521	572	585	610	658	683	768	806	911	855
H	111	118	126	126	134	145	168	168	220	220
HD	182	198	216	216	234	257	300	300	380	380
AC	138	156	176	176	194	218	257	257	310	310

**"A<sub>1</sub>" Ölçüsü Frenli Motorlar içindir.**  
Dimension "A<sub>1</sub>" is for motors with brake.  
*Le dimensions "A<sub>1</sub>" correspondent aux moteurs équipés de freins.*

**YPP 82**  
**YPP 83**

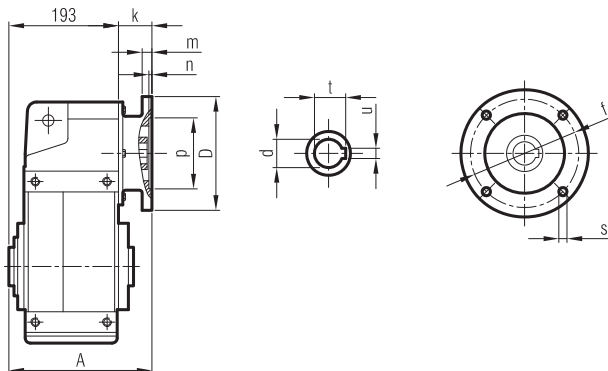

	A	Øp	Øf	ØD	s	k	m	n	Ød	t	u
71/B5	248	110	130	160	M8	55	10	4	14	16.3	5
80/B5	260	130	165	200	M10	67	12	5	19	21.8	6
90/B5	260	130	165	200	M10	67	12	5	24	27.3	8
100/B5	264	180	215	250	M12	71.5	14	5	28	31.3	8
112/B5	264	180	215	250	M12	71.5	14	5	28	31.3	8
132/B5	288	230	265	300	M12	95.5	17	5	38	41.3	10
160/B5	304	250	300	350	M14	111	18	6.5	42	45.3	12



**YPM / YP  
YPPM / YPP**

**... -SL**

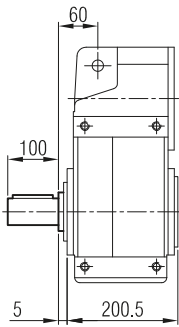

**... -H**

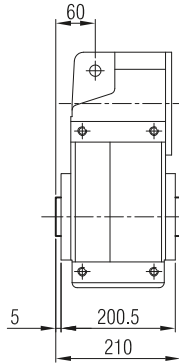

**... -SDL**

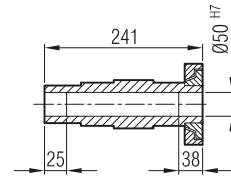
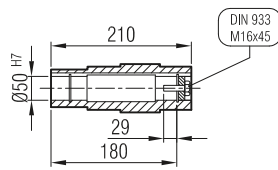
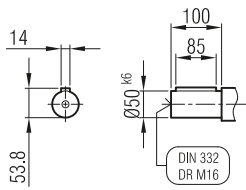
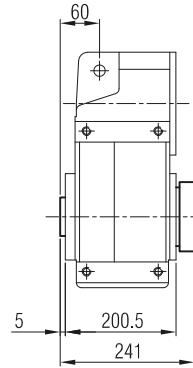

**YPFM / YPF  
YPPFM / YPPF**

**... -FL -SL**

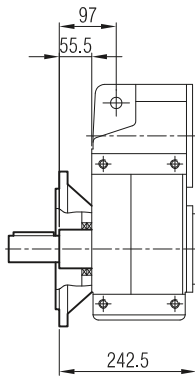

**... -FL**

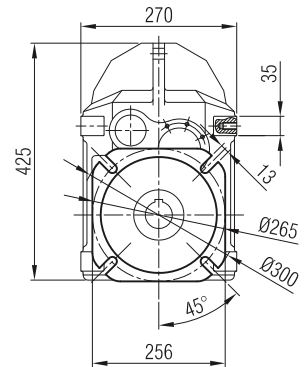
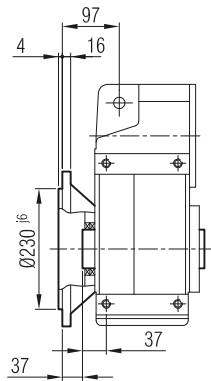

**-TL**

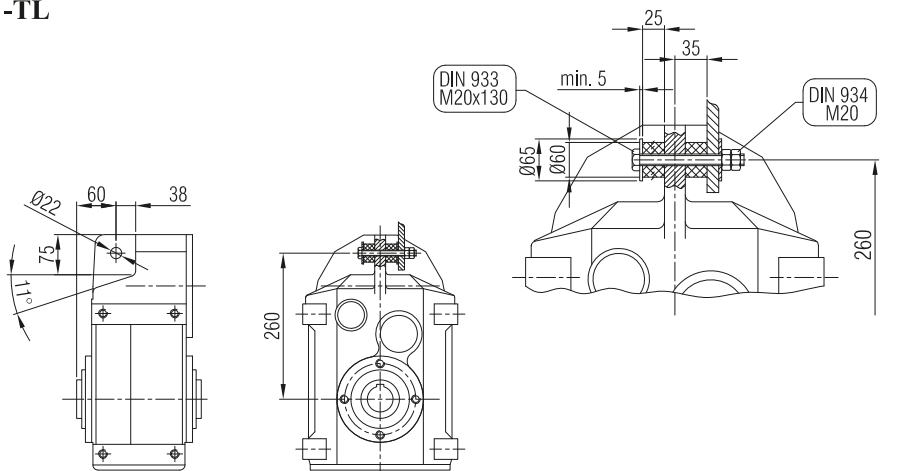

**Klemens Pozisyonları**  
Terminal Box Positions  
Klemenskasten Positionen

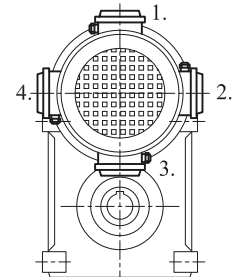

71, 90, 100, 112, 132  
B5 Tip/Type/Typ

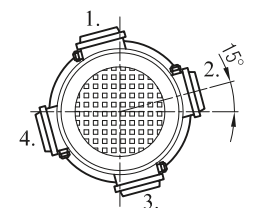

80 B5 Tip/Type/Typ



**YPM 84**

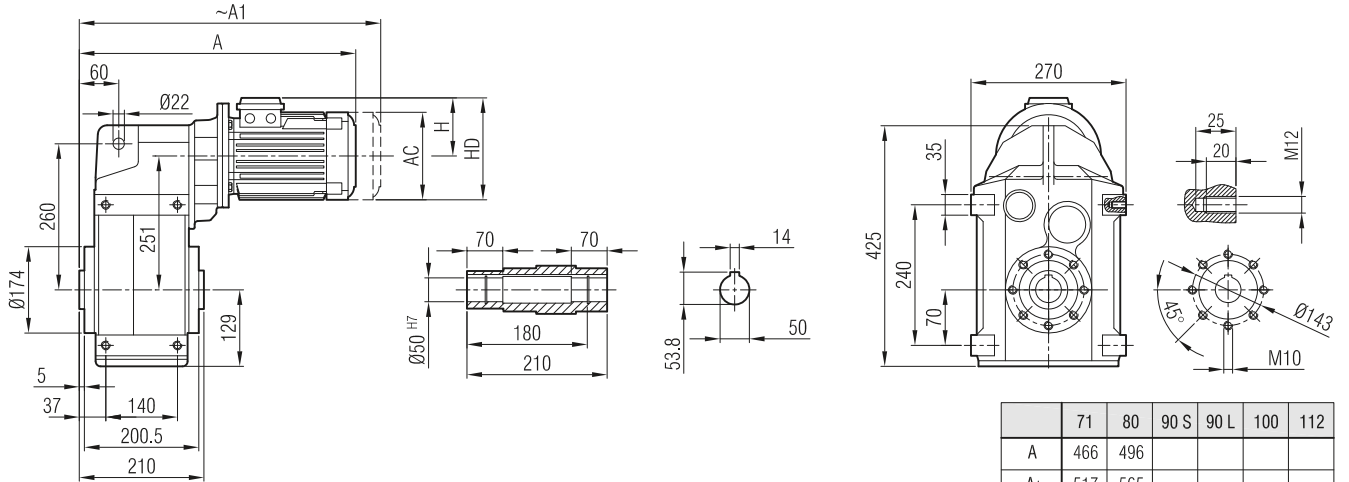

	71	80	90 S	90 L	100	112
A	466	496				
A <sub>1</sub>	517	565				
H	111	118				
HD	182	198				
AC	138	156				

**YP 84**

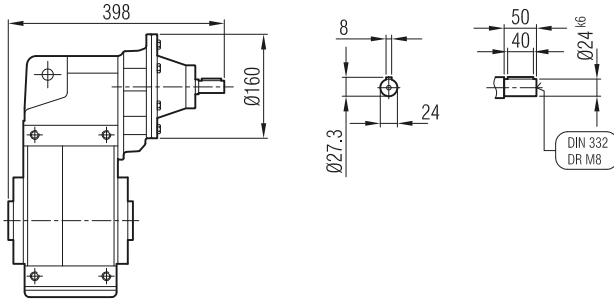

**"A<sub>1</sub>" Ölçüsü Frenli Motorlar içindir.**  
Dimension "A<sub>1</sub>" is for motors with brake.  
Le dimensions "A<sub>1</sub>" correspondent aux moteurs équipés de freins.

**YPPM 84**

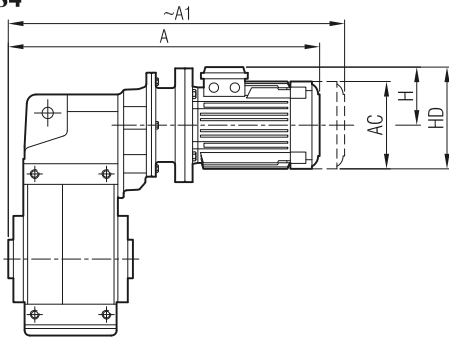

	63/B5	71/B5	80/B5	90 S/B5
A	488	523	549	
A <sub>1</sub>	544	574	618	
H	97	111	118	
HD	160	182	198	
AC	121	138	156	

**"A<sub>1</sub>" Ölçüsü Frenli Motorlar içindir.**  
Dimension "A<sub>1</sub>" is for motors with brake.  
Le dimensions "A<sub>1</sub>" correspondent aux moteurs équipés de freins.

**YPP 84**

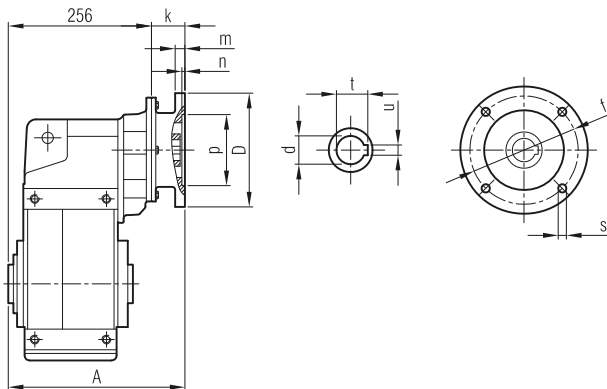

	A	Øp	Øf	ØD	s	k	m	n	Ød	t	u
63/B5	291	95	115	140	M8	35,5	8	4	11	12,8	4
71/B5	301	110	130	160	M8	45	10	4	14	16,3	5
80/B5	306	130	165	200	M10	50	12	5	19	21,8	6





**YPM / YP  
YPPM / YPP**

**... -SL**

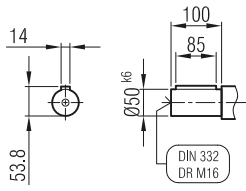
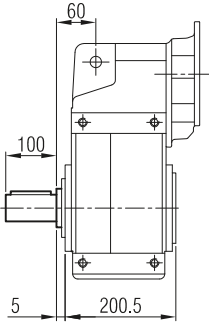

**... -H**

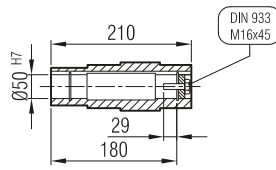
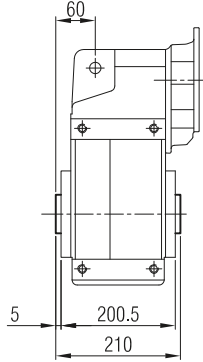

**... -SDL**

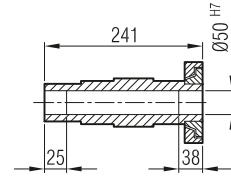
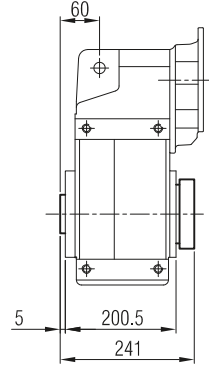

**YPFM / YPF  
YPPFM / YPPF**

**... -FL -SL**

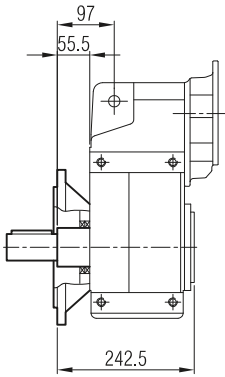

**... -FL**

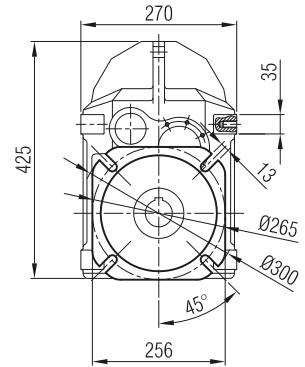
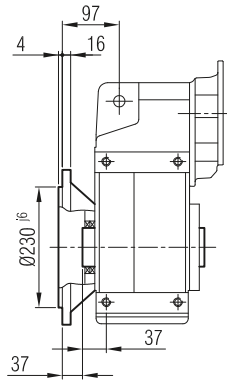

**-TL**

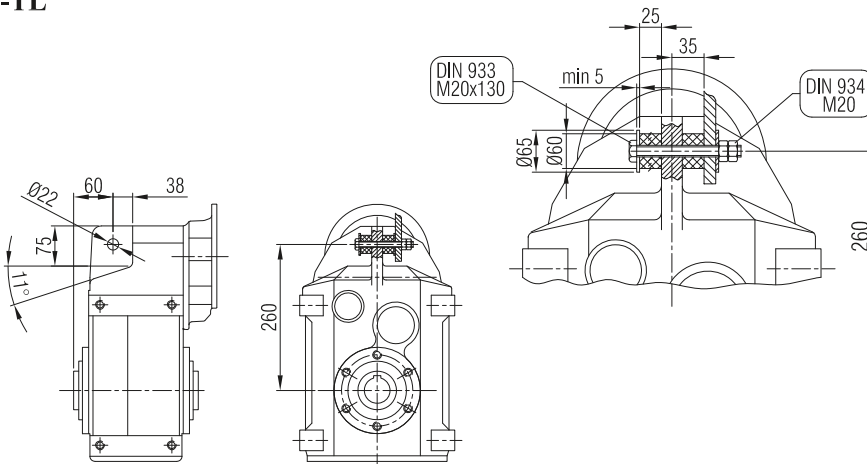

**Klemens Pozisyonları**  
Terminal Box Positions  
Klemenskasten Positionen

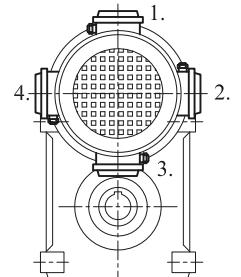

71, 90, 100, 112, 132  
B5 Tip/Type/Typ

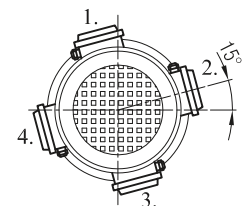

80 B5 Tip/Type/Typ



**YPM 82 İR 52 / YPM 82 İR 53**  
**YPM 83 İR 53**

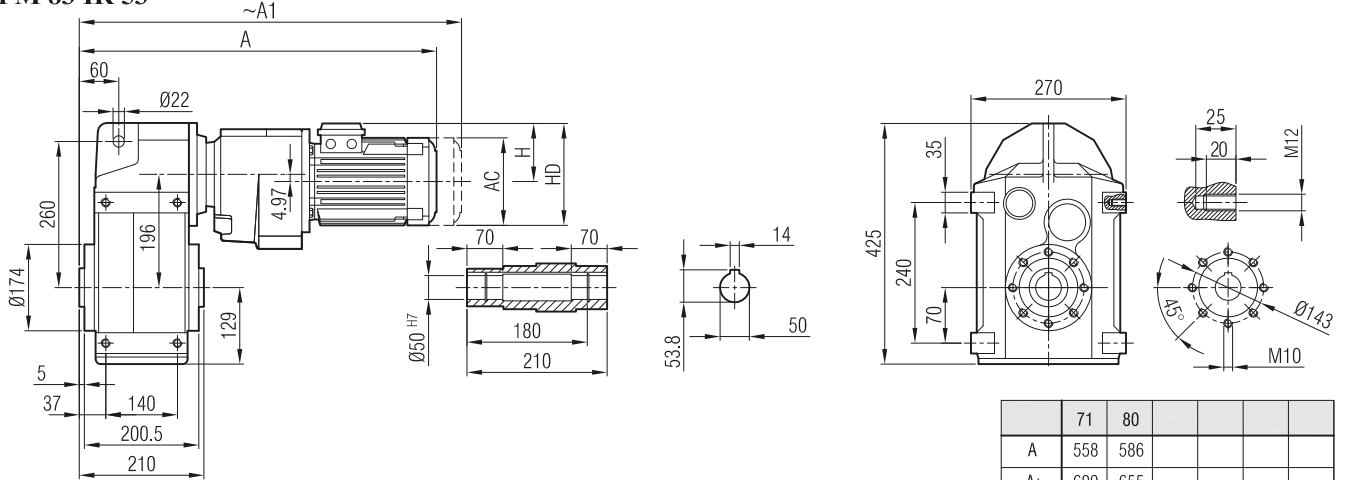

**YP 82 İR 52 / YP 82 İR 53**  
**YP 83 İR 52 / YP 83 İR 53**

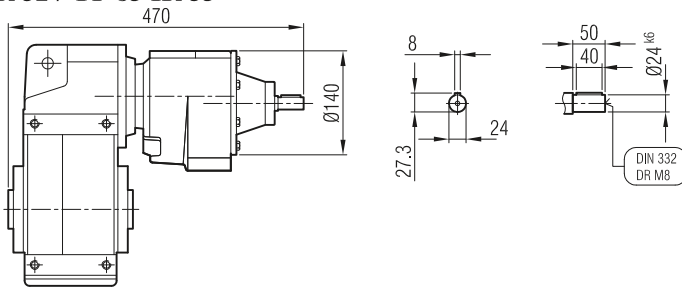

"A<sub>1</sub>" Ölçüsü Frenli Motorlar içindir.  
Dimension "A<sub>1</sub>" is for motors with brake.  
Le dimensions "A<sub>1</sub>" correspondent aux moteurs équipés de freins.

**YPPM 82 İR 52 / YPPM 82 İR 53**  
**YPPM 83 İR 53**

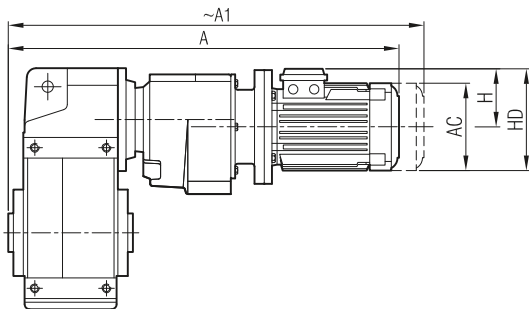

	63/B5	71/B5	80/B5	
A	573	607	630	
A <sub>1</sub>	629	658	699	
H	97	111	118	
HD	160	182	198	
AC	121	138	156	

"A<sub>1</sub>" Ölçüsü Frenli Motorlar içindir.  
Dimension "A<sub>1</sub>" is for motors with brake.  
Le dimensions "A<sub>1</sub>" correspondent aux moteurs équipés de freins.

**YPP 82 İR 52 / YPP 82 İR 53**  
**YPP 83 İR 53**

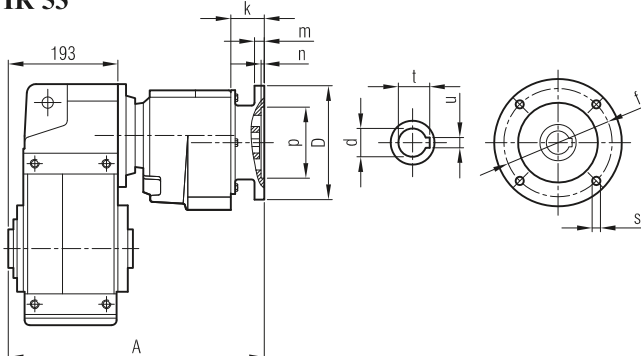

	A	Øp	Øf	ØD	s	k	m	n	Ød	t	u
63/B5	184	95	115	140	M8	35,5	8	4	11	12,8	4
71/B5	385	110	130	160	M8	44	9	4	14	16,3	5
80/B5	387	130	165	200	M10	46	12	5	19	21,8	6



**YPM / YP  
YPPM / YPP**

**... -SL**

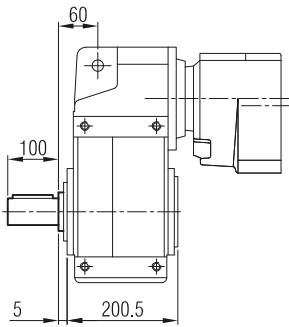

**... -H**

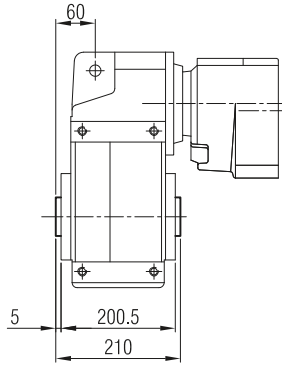

**... -SDL**

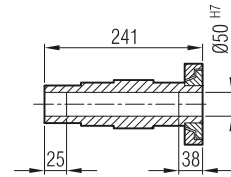
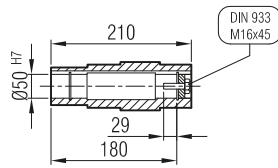
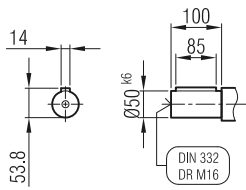
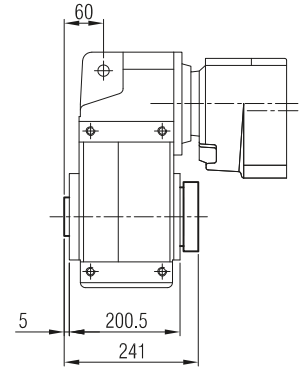

**YPFM / YPF  
YPPFM / YPPF**

**... -FL -SL**

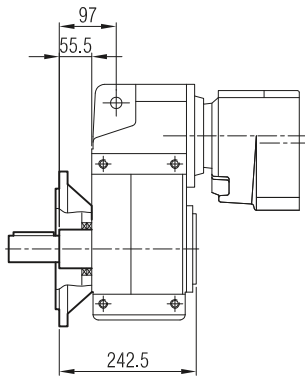

**... -FL**

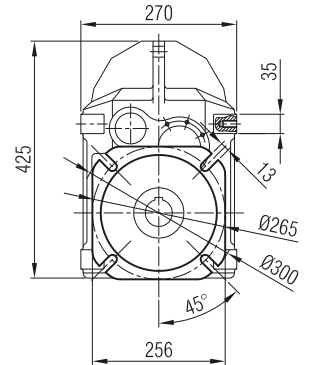
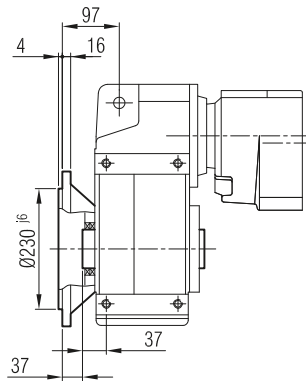

**-TL**

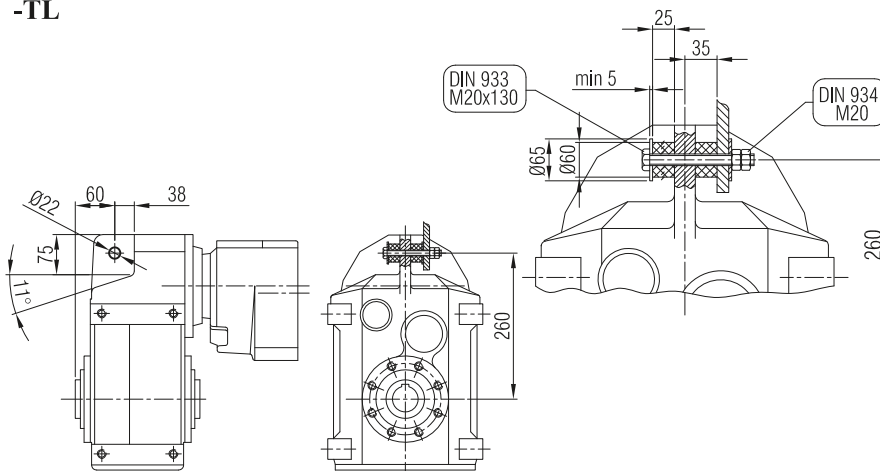

**Klemens Pozisyonları**  
Terminal Box Positions  
Klemenskasten Positionen

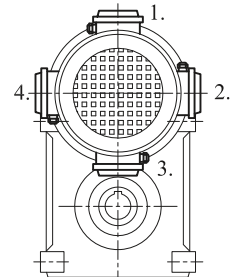

71, 90, 100, 112, 132  
B5 Tip/Type/Typ

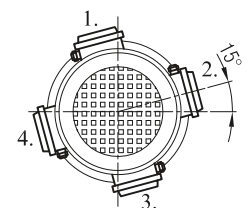

80 B5 Tip/Type/Typ



**YPM 92  
YPM 93**

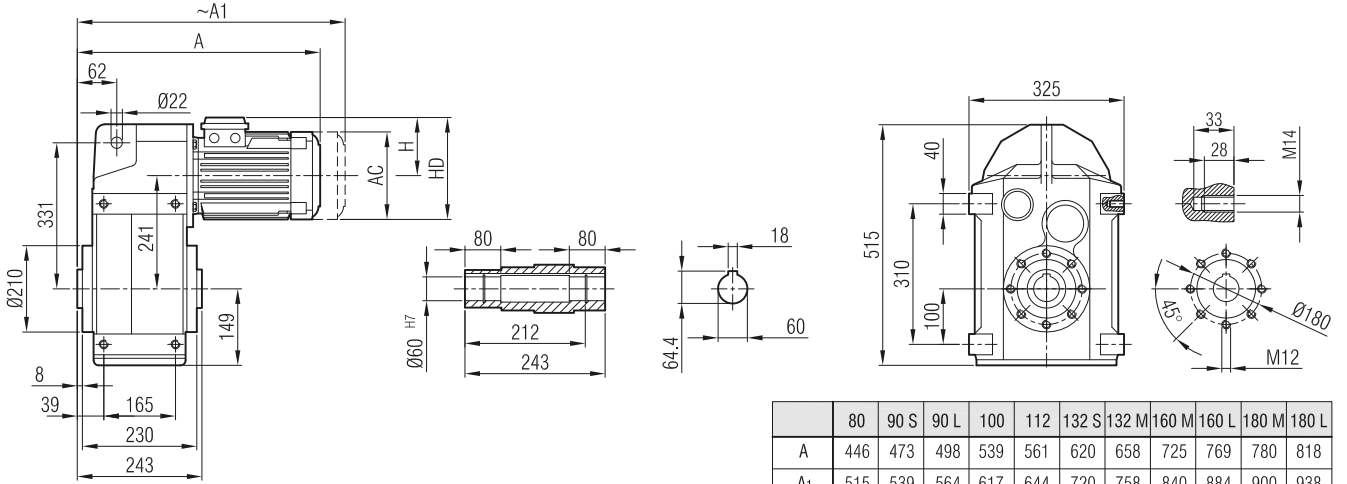

	80	90 S	90 L	100	112	132 S	132 M	160 M	160 L	180 M	180 L
A	446	473	498	539	561	620	658	725	769	780	818
A <sub>1</sub>	515	539	564	617	644	720	758	840	884	900	938
H	118	126	126	134	145	168	168	220	220	241	241
HD	198	216	216	234	257	300	300	380	380	421	421
AC	156	176	176	194	218	257	257	310	310	348	348

"A<sub>1</sub>" Ölçüsü Frenli Motorlar içindir.  
Dimension "A<sub>1</sub>" is for motors with brake.  
Le dimensions "A<sub>1</sub>" correspondent aux moteurs équipés de freins.

**YP 92  
YP 93**

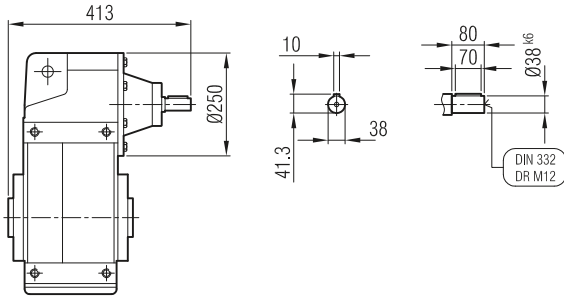

**YPPM 92  
YPPM 93**

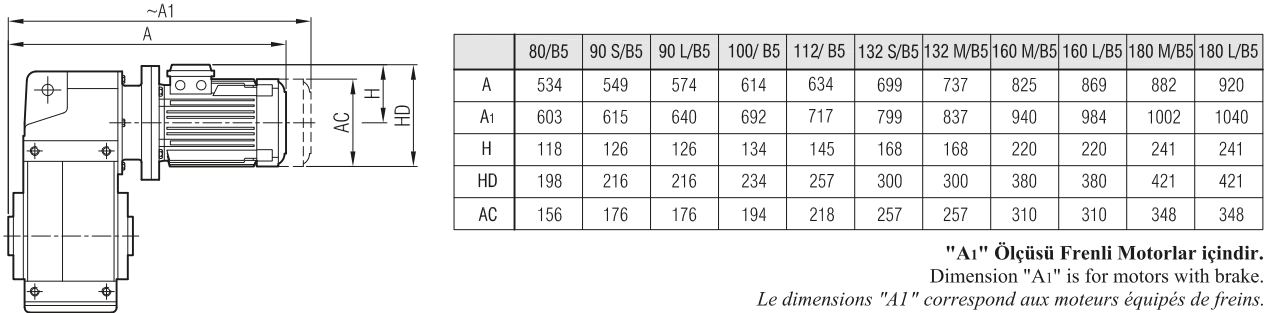

	80/B5	90 S/B5	90 L/B5	100/ B5	112/ B5	132 S/B5	132 M/B5	160 M/B5	160 L/B5	180 M/B5	180 L/B5
A	534	549	574	614	634	699	737	825	869	882	920
A <sub>1</sub>	603	615	640	692	717	799	837	940	984	1002	1040
H	118	126	126	134	145	168	168	220	220	241	241
HD	198	216	216	234	257	300	300	380	380	421	421
AC	156	176	176	194	218	257	257	310	310	348	348

"A<sub>1</sub>" Ölçüsü Frenli Motorlar içindir.  
Dimension "A<sub>1</sub>" is for motors with brake.  
Le dimensions "A<sub>1</sub>" correspondent aux moteurs équipés de freins.

**YPP 92  
YPP 93**

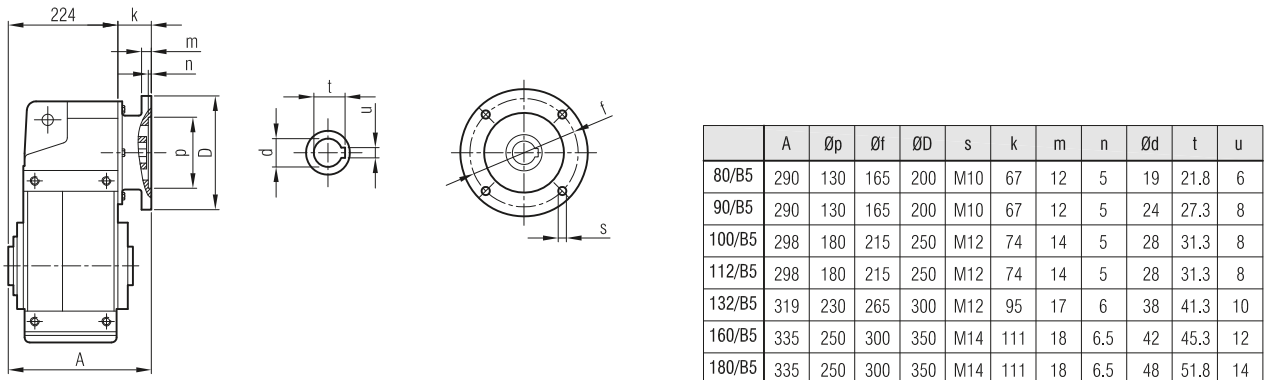

	A	Øp	Øf	ØD	s	k	m	n	Ød	t	u
80/B5	290	130	165	200	M10	67	12	5	19	21.8	6
90/B5	290	130	165	200	M10	67	12	5	24	27.3	8
100/B5	298	180	215	250	M12	74	14	5	28	31.3	8
112/B5	298	180	215	250	M12	74	14	5	28	31.3	8
132/B5	319	230	265	300	M12	95	17	6	38	41.3	10
160/B5	335	250	300	350	M14	111	18	6.5	42	45.3	12
180/B5	335	250	300	350	M14	111	18	6.5	48	51.8	14



**YPM / YP  
YPPM / YPP**

**... -SL**

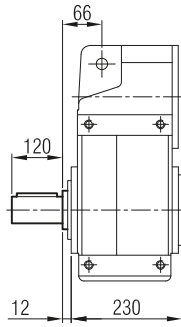

**... -H**

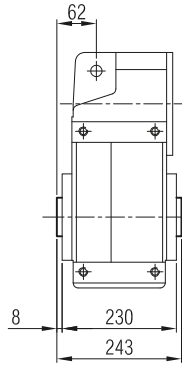

**... -SDL**

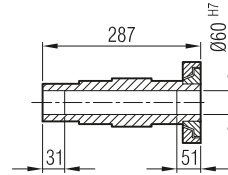
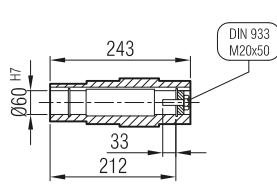
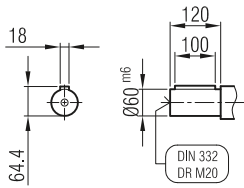
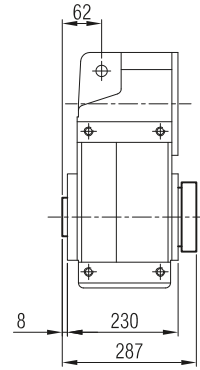

**YPFM / YPF  
YPFPM / YFPF**

**... -FL -SL**

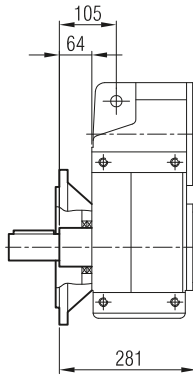

**... -FL**

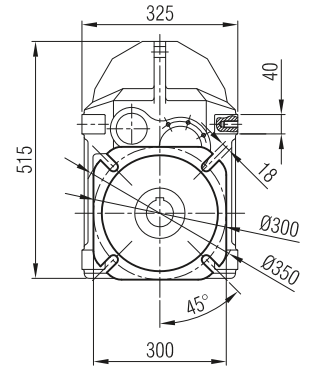
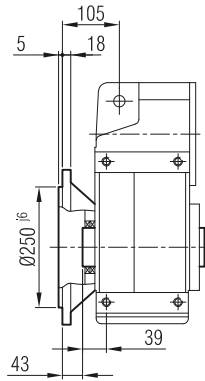

**-TL**

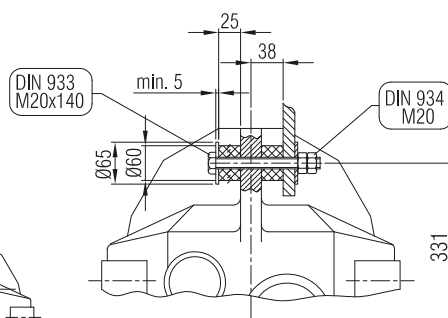
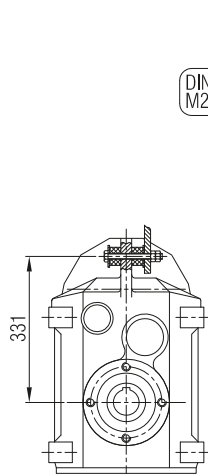
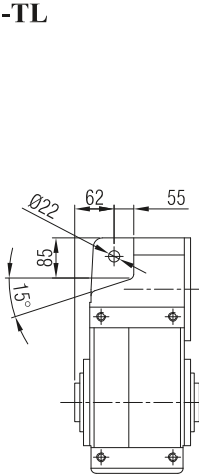

**Klemens Pozisyonları**  
Terminal Box Positions  
Klemenskasten Positionen

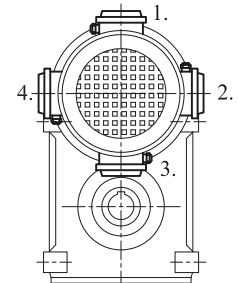



**YPM 94**

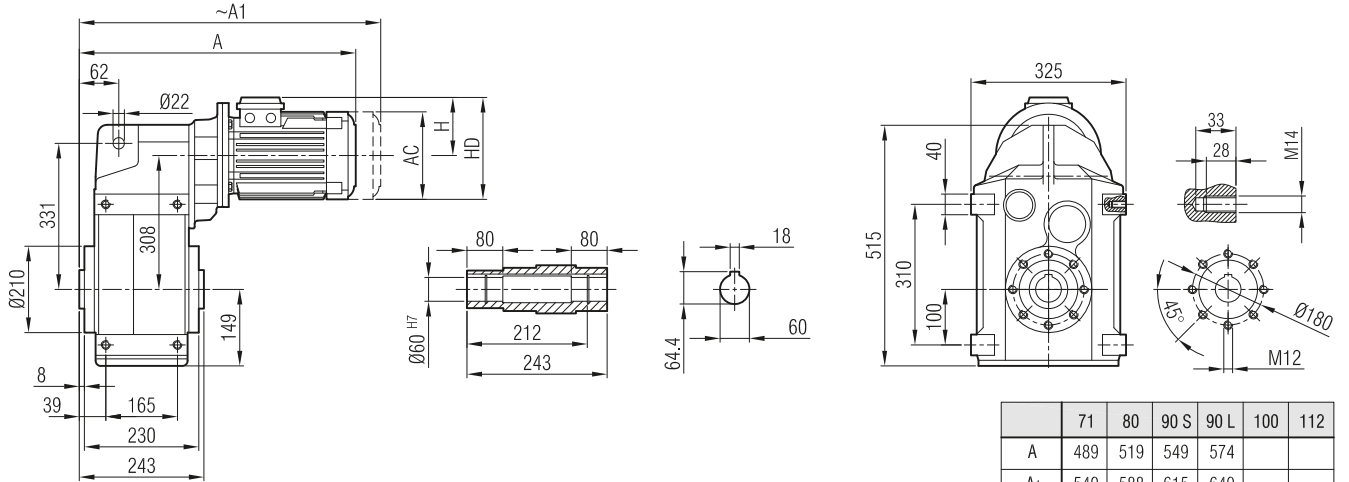

	71	80	90 S	90 L	100	112
A	489	519	549	574		
A <sub>1</sub>	540	588	615	640		
H	111	118	126	126		
HD	182	198	216	216		
AC	138	156	176	176		

**"A<sub>1</sub>" Ölçüsü Frenli Motorlar içindir.**  
Dimension "A<sub>1</sub>" is for motors with brake.  
Le dimensions "A<sub>1</sub>" correspondent aux moteurs équipés de freins.

**YP 94**

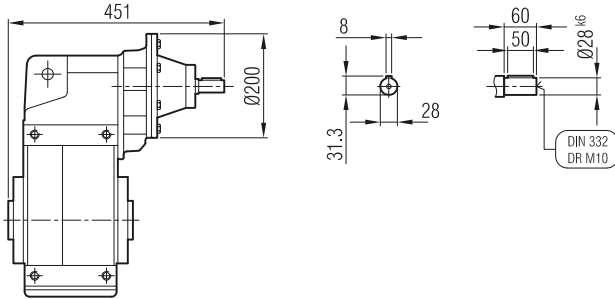

**YPPM 94**

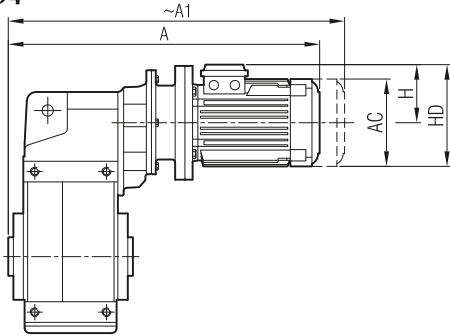

	71/B5	80/B5	90 S/B5	90 L/B5
A	565	598	613	638
A <sub>1</sub>	616	667	679	704
H	111	118	126	126
HD	182	198	216	216
AC	138	156	176	176

**"A<sub>1</sub>" Ölçüsü Frenli Motorlar içindir.**  
Dimension "A<sub>1</sub>" is for motors with brake.  
Le dimensions "A<sub>1</sub>" correspondent aux moteurs équipés de freins.

**YPP 94**

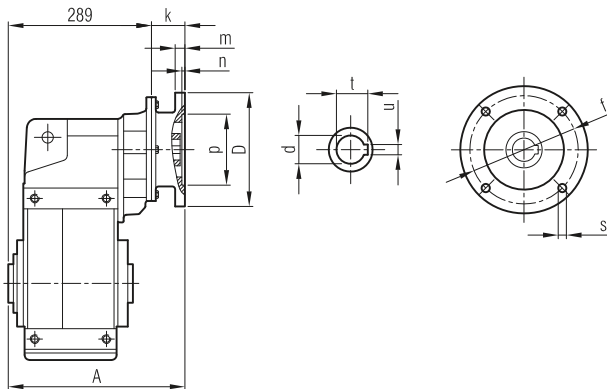

	A	Øp	Øf	ØD	s	k	m	n	Ød	t	u
71/B5	342	110	130	160	M8	55	10	4	14	16.3	5
80/B5	354	130	165	200	M10	67	12	5	19	21.8	6
90/B5	354	130	165	200	M10	67	12	5	24	27.3	8



**YPM / YP  
YPPM / YPP**

**... -SL**

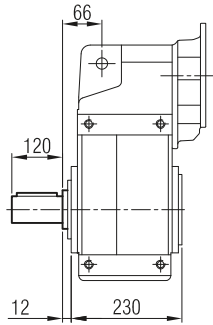

**... -H**

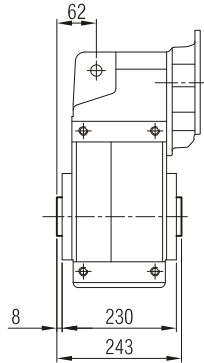

**... -SDL**

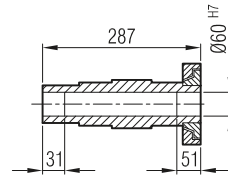
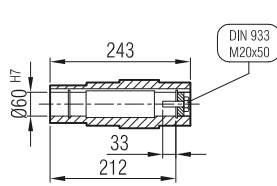
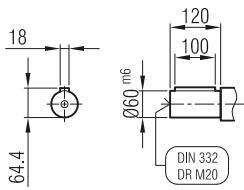
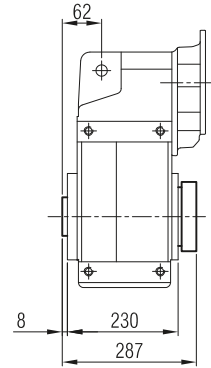

**YPFM / YPF  
YPFPM / YPF**

**... -FL -SL**

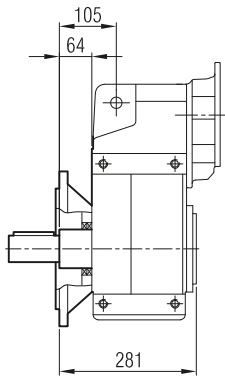

**... -FL**

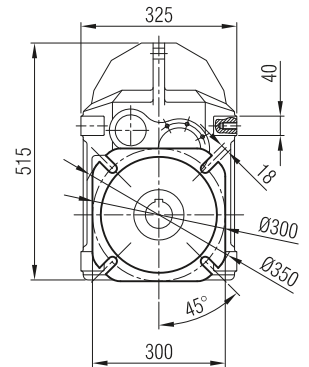
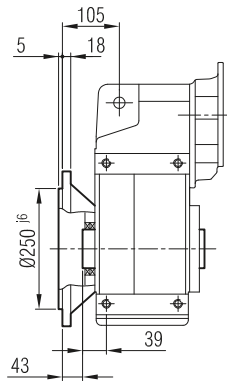

**-TL**

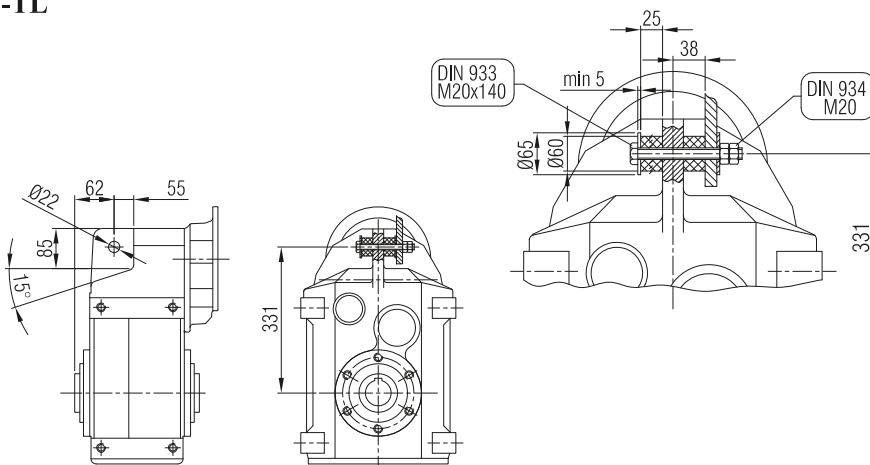

**Klemens Pozisyonları**  
Terminal Box Positions  
Klemenskasten Positionen

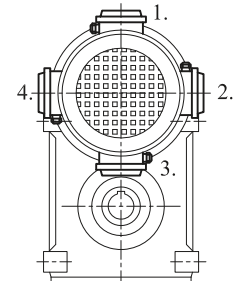



**YPM 92 İR 62 / YPM 92 İR 63**  
**YPM 93 İR 63**

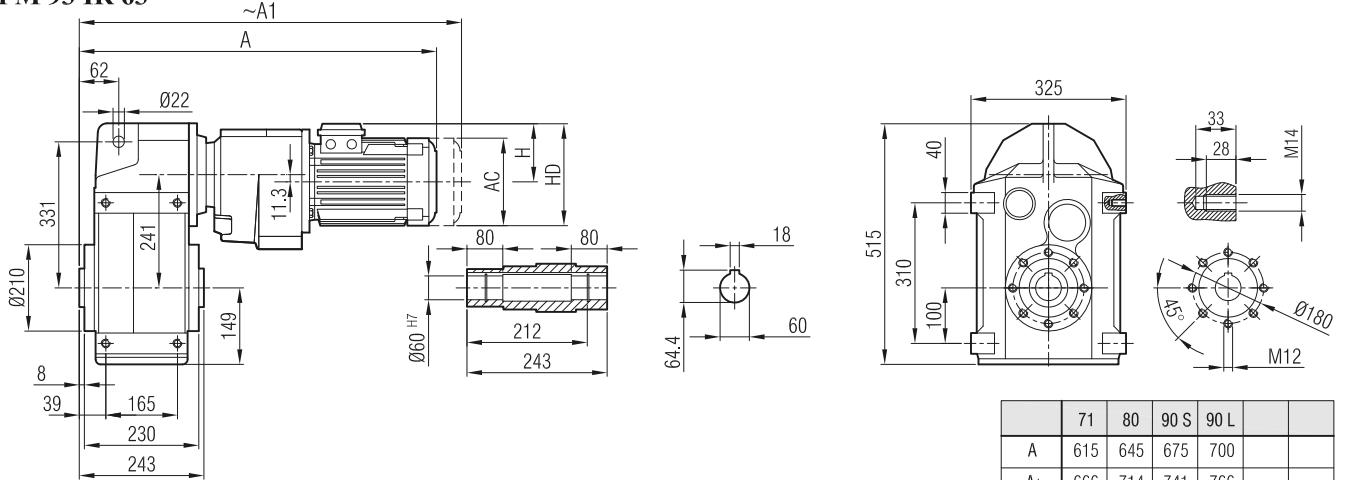

	71	80	90 S	90 L		
A	615	645	675	700		
A <sub>1</sub>	666	714	741	766		
H	111	118	126	126		
HD	182	198	216	216		
AC	138	156	176	176		

**YP 92 İR 62 / YP 92 İR 63**  
**YP 93 İR 62 / YP 93 İR 63**

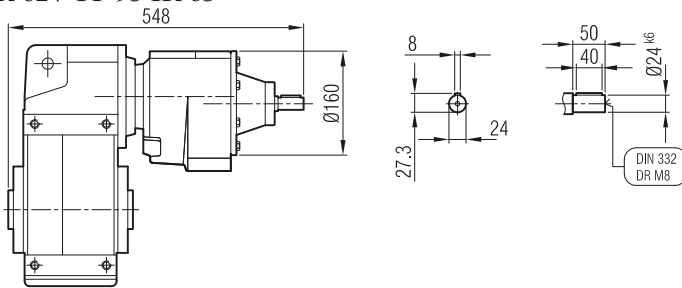

"A<sub>1</sub>" Ölçüsü Frenli Motorlar içindir.  
Dimension "A<sub>1</sub>" is for motors with brake.  
Le dimensions "A<sub>1</sub>" correspondent aux moteurs équipés de freins.

**YPPM 92 İR 62 / YPPM 92 İR 63**  
**YPPM 93 İR 63**

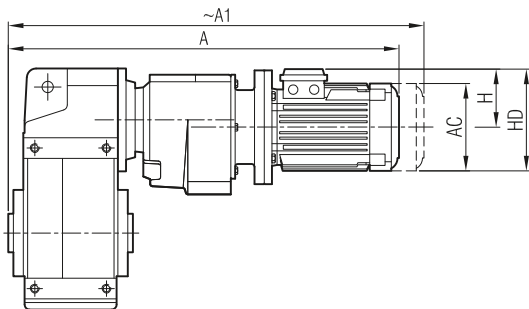

	63/B5	71/B5	80/B5	90 S/B5	90 L/B5
A	637	672	698	714	739
A <sub>1</sub>	693	723	767	780	805
H	97	111	118	126	126
HD	160	182	198	216	216
AC	121	138	156	176	176

"A<sub>1</sub>" Ölçüsü Frenli Motorlar içindir.  
Dimension "A<sub>1</sub>" is for motors with brake.  
Le dimensions "A<sub>1</sub>" correspondent aux moteurs équipés de freins.

**YPP 92 İR 62 / YPP 92 İR 63**  
**YPP 93 İR 63**

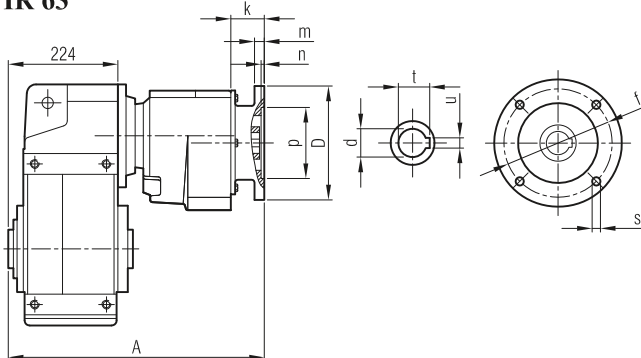

	A	Øp	Øf	ØD	s	k	m	n	Ød	t	u
63/B5	441	95	115	140	M8	35.5	8	4	11	12.8	4
71/B5	450	110	130	160	M8	45	9	4	14	16.3	5
80/B5	455	130	165	200	M10	50	12	5	19	21.8	6
90/B5	455	130	165	200	M10	50	12	5	24	27.3	8





**YPM / YP  
YPPM / YPP**

**... -SL**

**... -H**

**... -SDL**

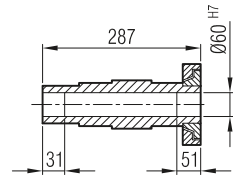
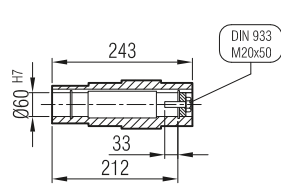
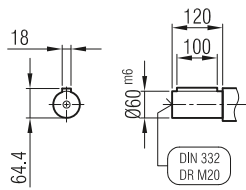
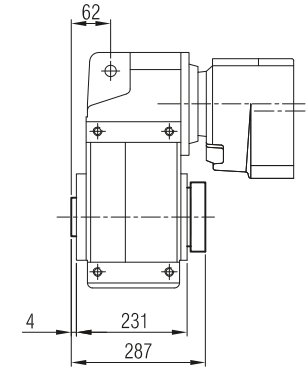
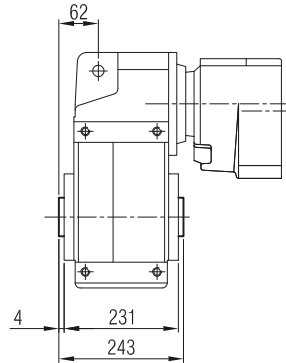
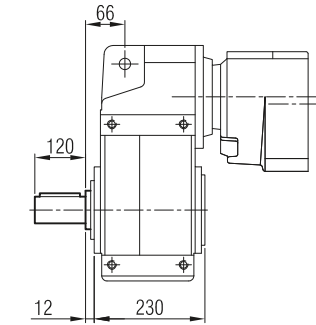

**YPFM / YPF  
YPFPM / YPF**

**... -FL -SL**

**... -FL**

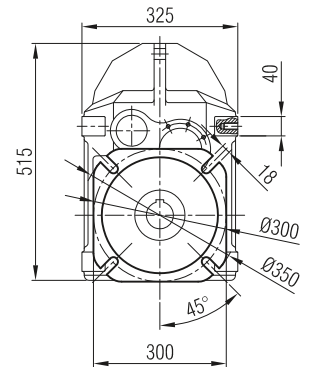
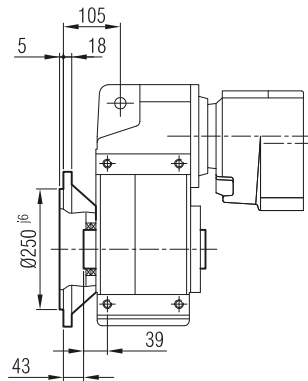
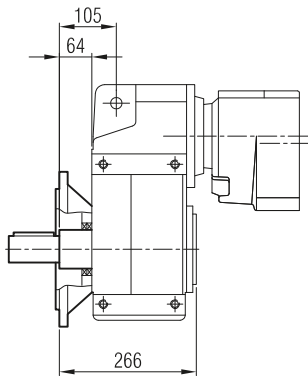

**-TL**

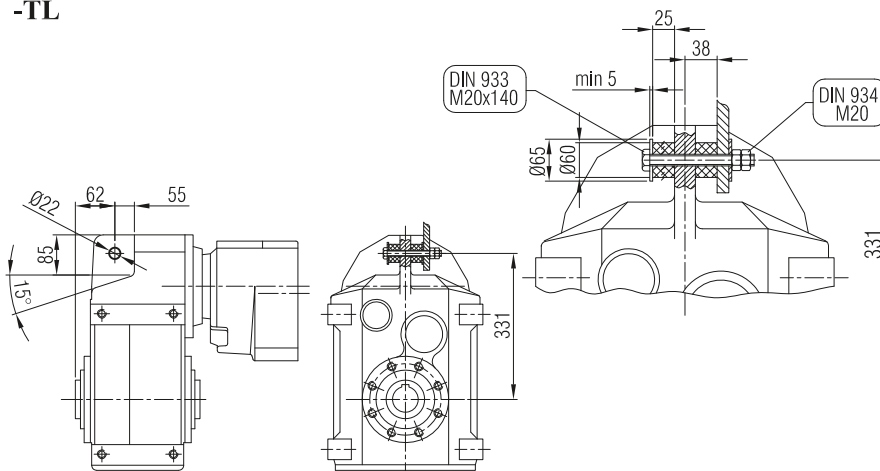

**Klemens Pozisyonları**  
Terminal Box Positions  
Klemenskasten Positionen

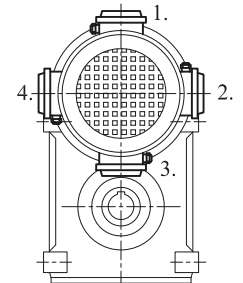



**YPM 102**  
**YPM 103**

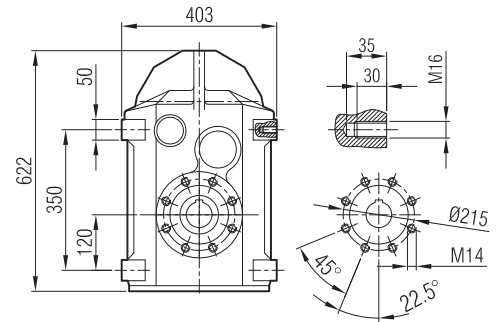
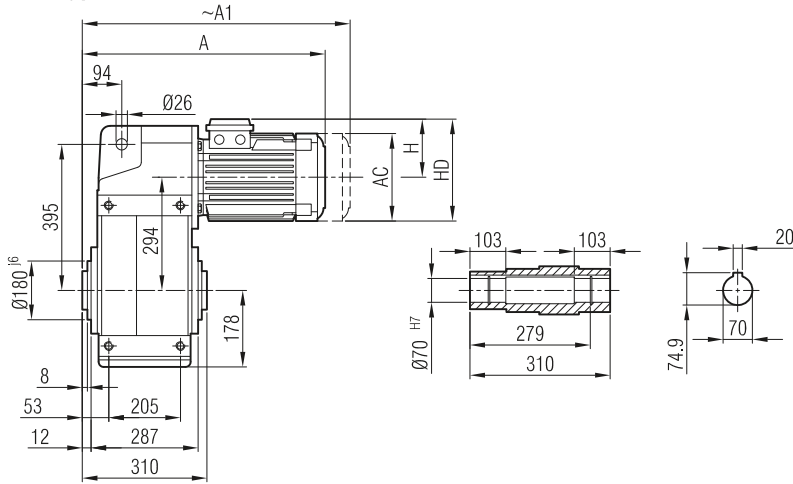

	100	112	132 S	132 M	160 M	160 L	180 M	180 L	200
A	582	604	656	694	784	828	847	885	920
A <sub>1</sub>	660	687	756	794	899	943	967	1005	1040
H	134	145	168	168	220	220	241	241	277
HD	234	257	300	300	380	380	421	421	477
AC	194	218	257	257	310	310	348	348	390

**YP 102**  
**YP 103**

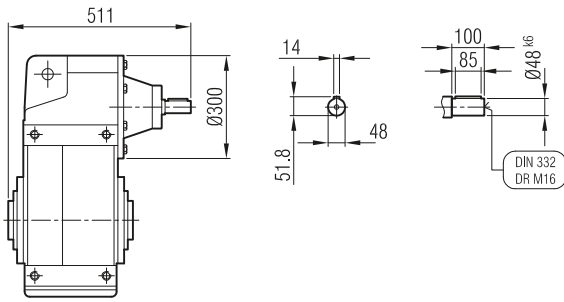

**YPPM 102**  
**YPPM 103**

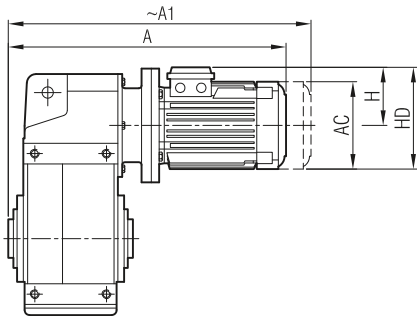

	90 S/B5	90 L/B5	100/ B5	112/ B5	132 S/B5	132 M/B5	160 M/B5	160 L/B5	180 M/B5	180 L/B5	200/B5
A	584	609	650	670	751	789	877	921	934	972	1072
A <sub>1</sub>	650	675	728	753	851	889	992	1036	1054	1092	1192
H	126	126	134	145	168	168	220	220	241	241	277
HD	216	216	234	257	300	300	380	380	421	421	477
AC	176	176	194	218	257	257	310	310	348	348	390

**YPP 102**  
**YPP 103**

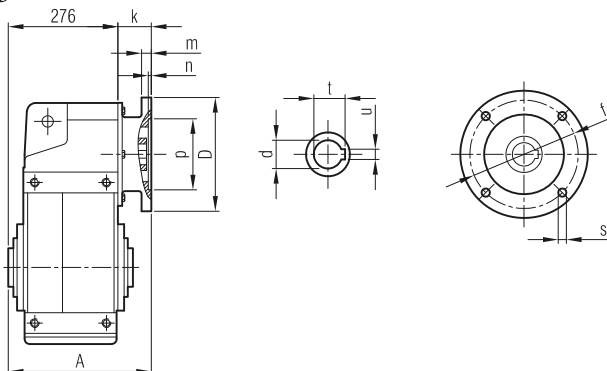

	A	Øp	Øf	ØD	s	k	m	n	Ød	t	u
90/B5	325	130	165	200	M10	49	12	5	24	27.3	8
100/B5	334	180	215	250	M12	58	14	5	28	31.3	8
112/B5	334	180	215	250	M12	58	14	5	28	31.3	8
132/B5	371	230	265	300	M12	95	17	6	38	41.3	10
160/B5	387	250	300	350	M14	111	18	6.5	42	45.3	12
180/B5	387	250	300	350	M14	111	18	6.5	48	51.8	14
200/B5	435	300	350	400	M16	159	20	6.5	55	59.3	16

"A<sub>1</sub>" Ölçüsü Frenli Motorlar içindir.  
Dimension "A<sub>1</sub>" is for motors with brake.  
Le dimensions "A<sub>1</sub>" correspondent aux moteurs équipés de freins.

"A<sub>1</sub>" Ölçüsü Frenli Motorlar içindir.  
Dimension "A<sub>1</sub>" is for motors with brake.  
Le dimensions "A<sub>1</sub>" correspondent aux moteurs équipés de freins.



**YPM / YP  
YPPM / YPP**

**... -SL**

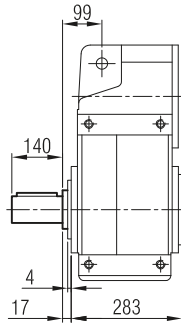

**... -H**

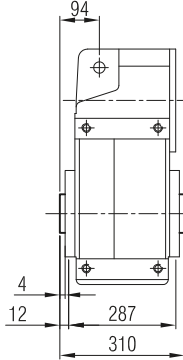

**... -SDL**

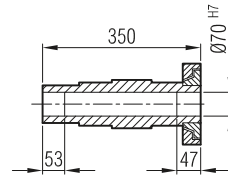
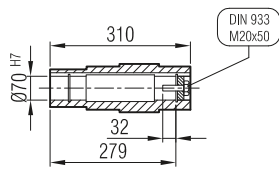
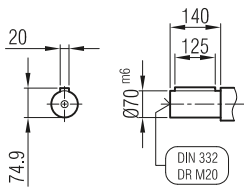
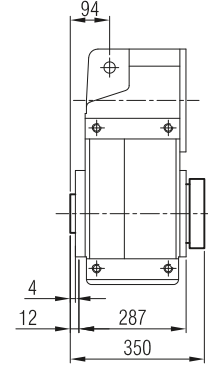

**YPFM / YPF  
YPFPM / YPF**

**... -FL -SL**

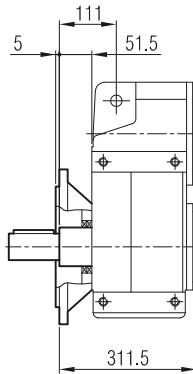

**... -FL**

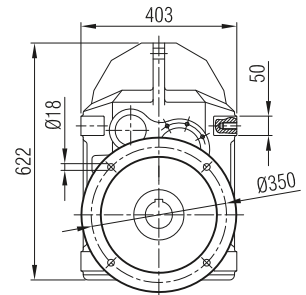
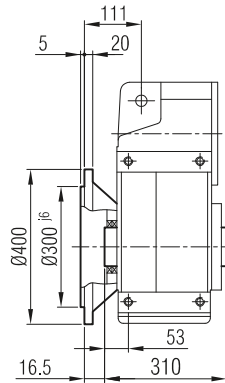

**-TL**

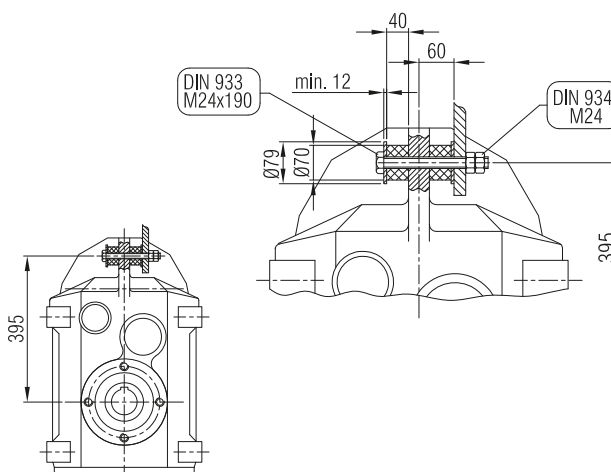
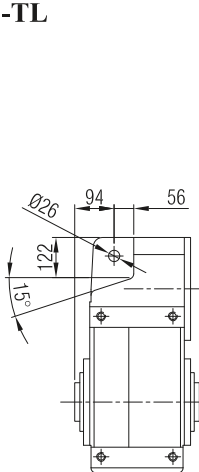

**Klemens Pozisyonları**  
Terminal Box Positions  
Klemenskasten Positionen

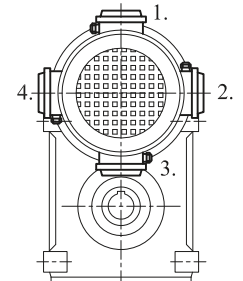



**YPM 104**

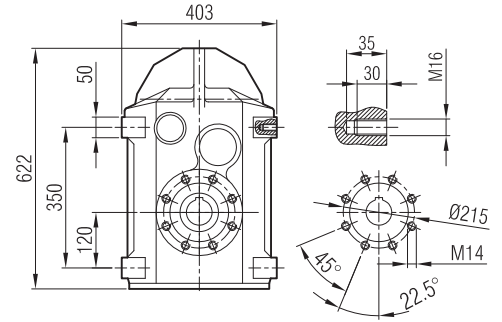
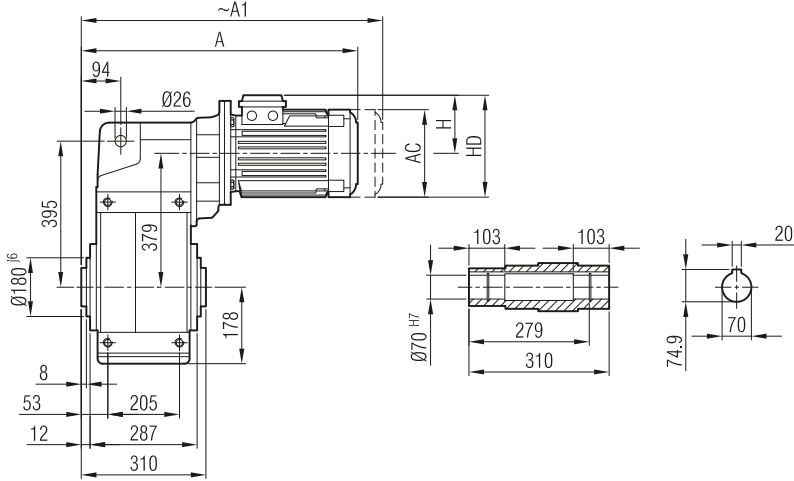

	80	90 S	90 L	100	112	132 S	132 M
A	565	593	618	658	680	742	780
A <sub>1</sub>	634	659	684	736	763	842	880
H	118	126	126	134	145	168	168
HD	198	216	216	234	257	300	300
AC	156	176	176	194	218	257	257

**"A<sub>1</sub>" Ölçüsü Frenli Motorlar içindir.**  
Dimension "A<sub>1</sub>" is for motors with brake.  
*Le dimensions "A<sub>1</sub>" correspondent aux moteurs équipés de freins.*

**YP 104**

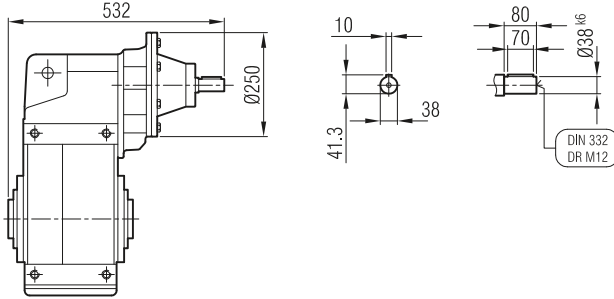

**YPPM 104**

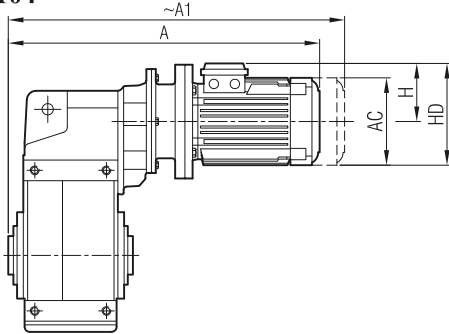

	80/B5	90 S/B5	90 L/B5	100/B5	112/B5	132 S/B5	132 M/B5
A	653	668	693	733	753	818	856
A <sub>1</sub>	722	734	759	811	836	918	956
H	118	126	126	134	145	168	168
HD	198	216	216	234	257	300	300
AC	156	176	176	194	218	257	257

**"A<sub>1</sub>" Ölçüsü Frenli Motorlar içindir.**  
Dimension "A<sub>1</sub>" is for motors with brake.  
*Le dimensions "A<sub>1</sub>" correspondent aux moteurs équipés de freins.*

**YPP 104**

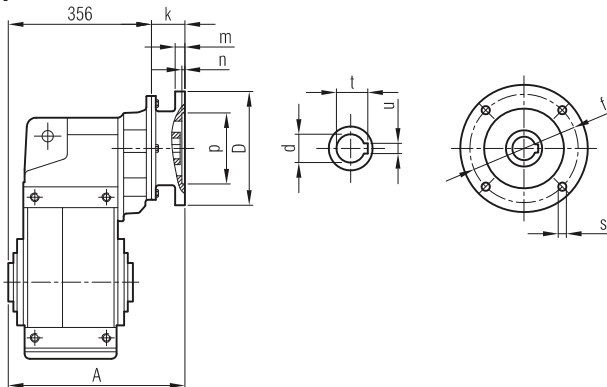

	A	Øp	Øf	ØD	s	k	m	n	Ød	t	u
80/B5	409	130	165	200	M10	67	12	5	19	21.8	6
90/B5	409	130	165	200	M10	67	12	5	24	27.3	8
100/B5	417	180	215	250	M12	74	14	5	28	31.3	8
112/B5	417	180	215	250	M12	74	14	5	28	31.3	8
132/B5	438	230	265	300	M12	95	17	6	38	41.3	10



**YPM / YP  
YPPM / YPP ... -SL**

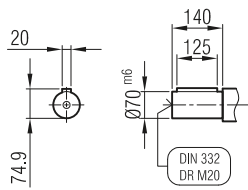
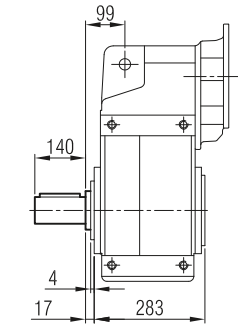

**... -H**

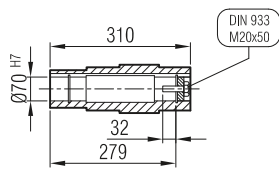
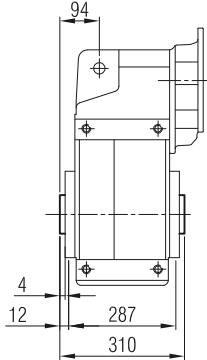

**... -SDL**

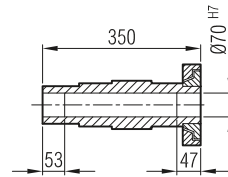
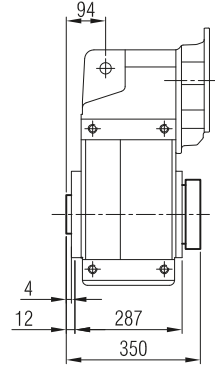

**YPFM / YPF  
YPFPM / YPF ... -FL -SL**

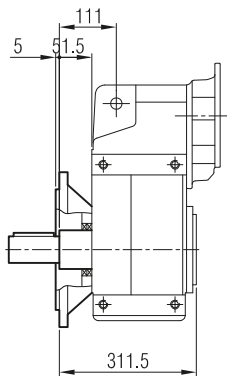

**... -FL**

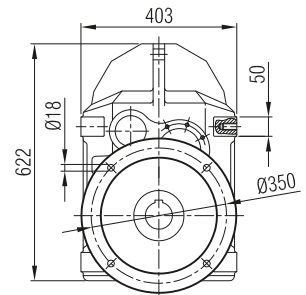
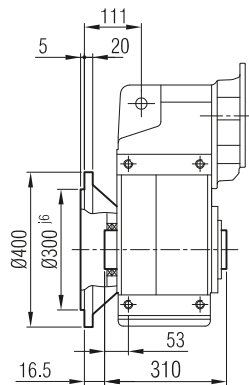

**-TL**

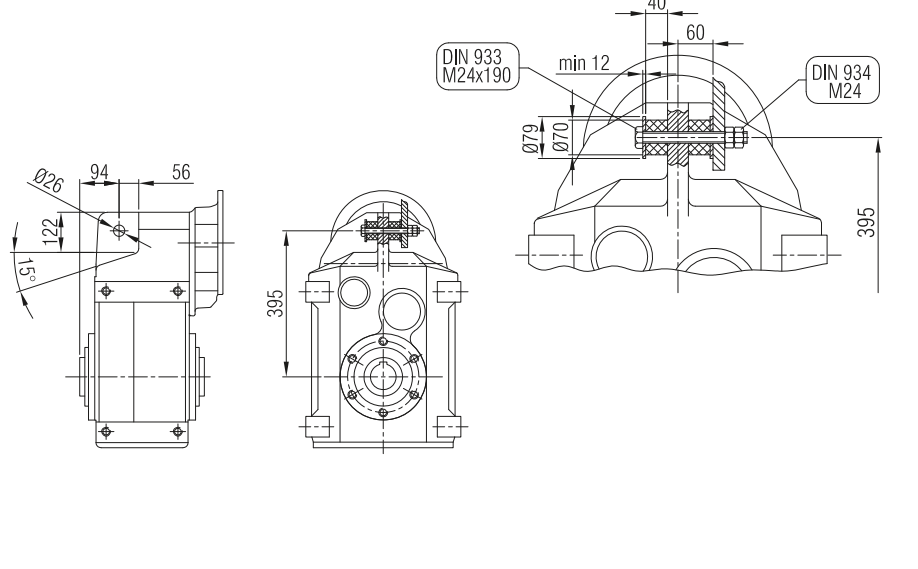

**Klemens Pozisyonları  
Terminal Box Positions  
Klemenskasten Positionen**

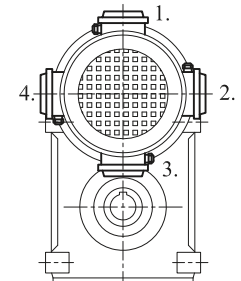



**YPM 102 İR 63**  
**YPM 103 İR 63**

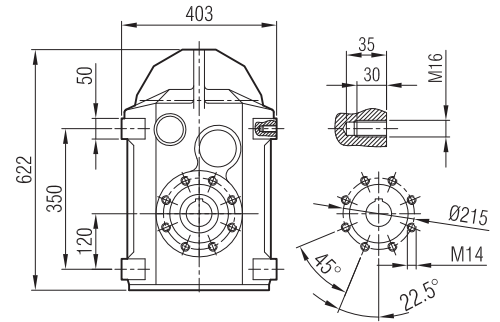
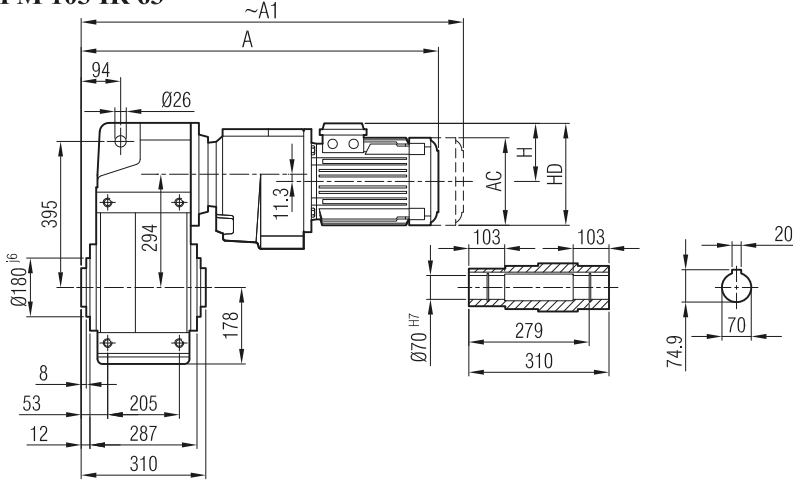

	71	80	90 S	90 L	
A	667	697	727	752	
A <sub>1</sub>	718	766	793	818	
H	111	118	126	126	
HD	182	198	216	216	
AC	138	156	176	176	

**YP 102 İR 62 / YP 102 İR 63**  
**YP 103 İR 62 / YP 103 İR 63**

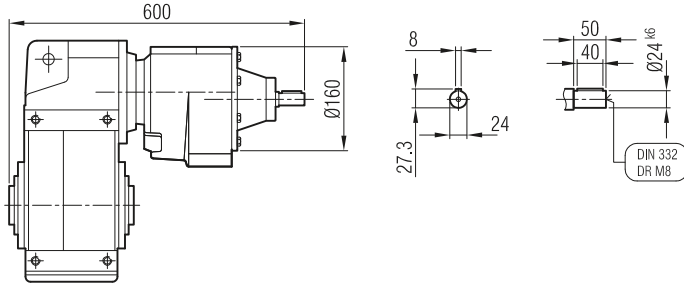

**"A<sub>1</sub>" Ölçüsü Frenli Motorlar içindir.**  
Dimension "A<sub>1</sub>" is for motors with brake.  
Le dimensions "A<sub>1</sub>" correspondent aux moteurs équipés de freins.

**YPPM 102 İR 63**  
**YPPM 103 İR 63**

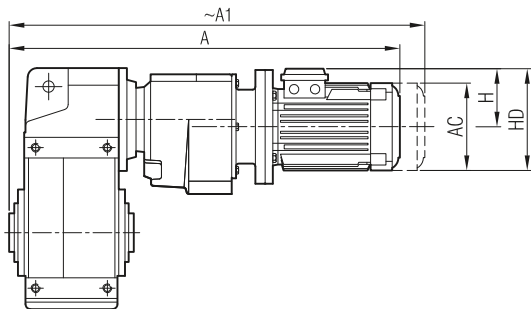

	63/B5	71/B5	80/B5	90 S/B5	90 L/B5
A	689	724	750	766	791
A <sub>1</sub>	745	775	819	832	857
H	97	111	118	126	126
HD	160	182	198	216	216
AC	121	138	156	176	176

**"A<sub>1</sub>" Ölçüsü Frenli Motorlar içindir.**  
Dimension "A<sub>1</sub>" is for motors with brake.  
Le dimensions "A<sub>1</sub>" correspondent aux moteurs équipés de freins.

**YPP 102 İR 63**  
**YPP 103 İR 63**

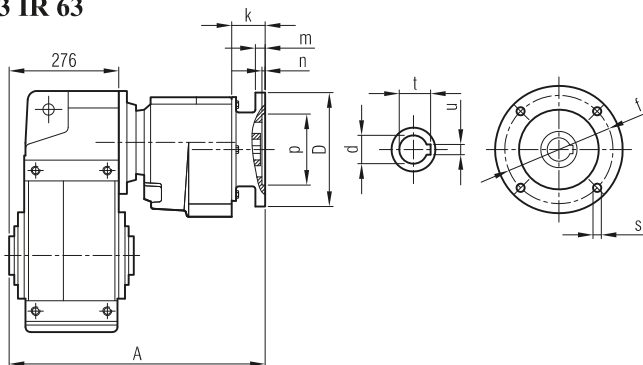

	A	Øp	Øf	ØD	s	k	m	n	Ød	t	u
63/B5	493	95	115	140	M8	35.5	8	4	11	12.8	4
71/B5	502	110	130	160	M8	45	9	4	14	16.3	5
80/B5	507	130	165	200	M10	50	12	5	19	21.8	6
90/B5	507	130	165	200	M10	50	12	5	24	27.3	8



**YPM / YP  
YPPM / YPP**

**... -SL**

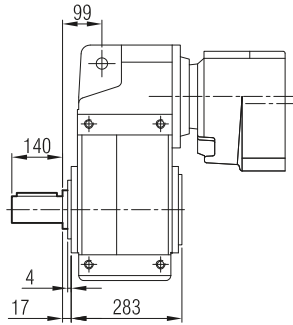

**... -H**

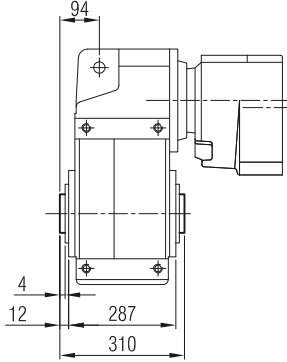

**... -SDL**

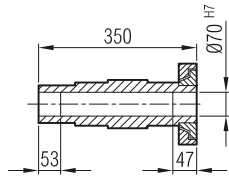
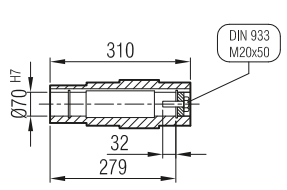
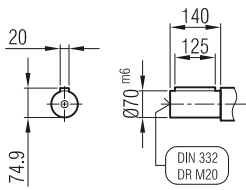
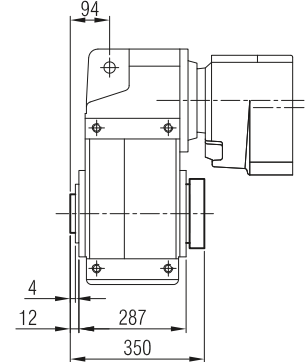

**YPFM / YPF  
YPFPM / YPF**

**... -FL -SL**

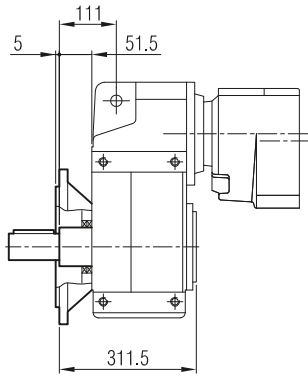

**... -FL**

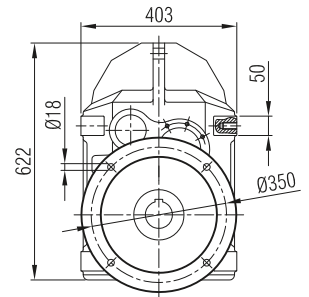
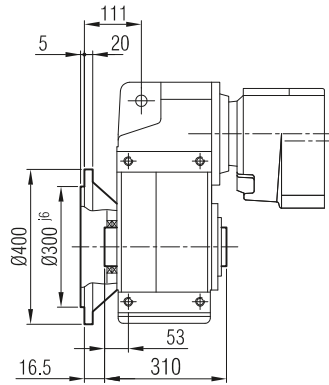

**-TL**

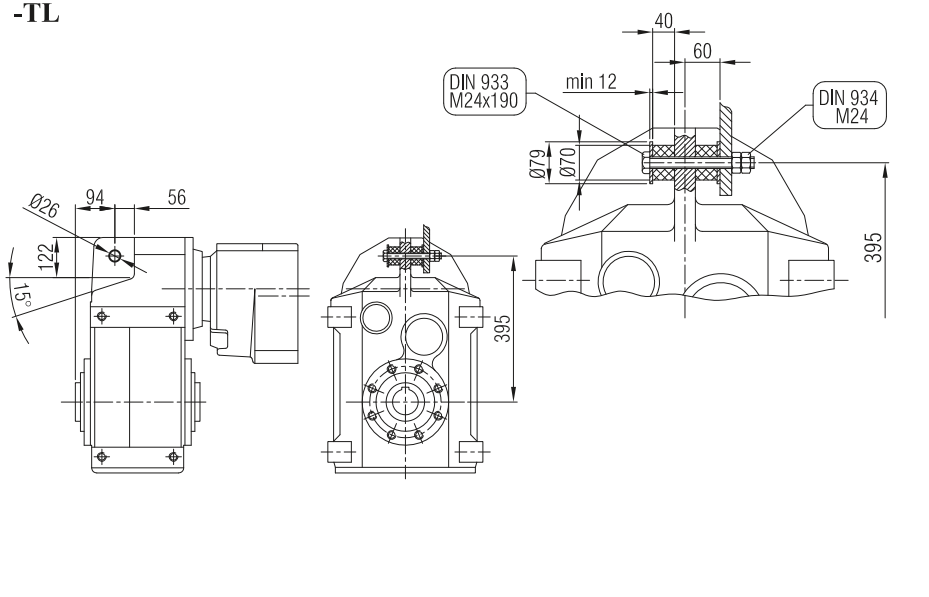

**Klemens Pozisyonları**  
Terminal Box Positions  
Klemenskasten Positionen

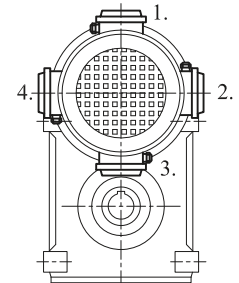



**YPM 122**  
**YPM 123**

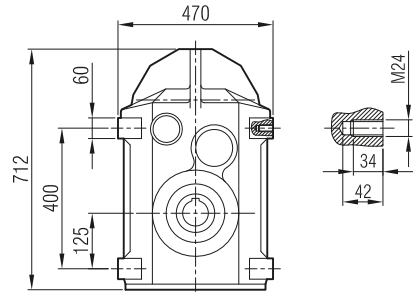
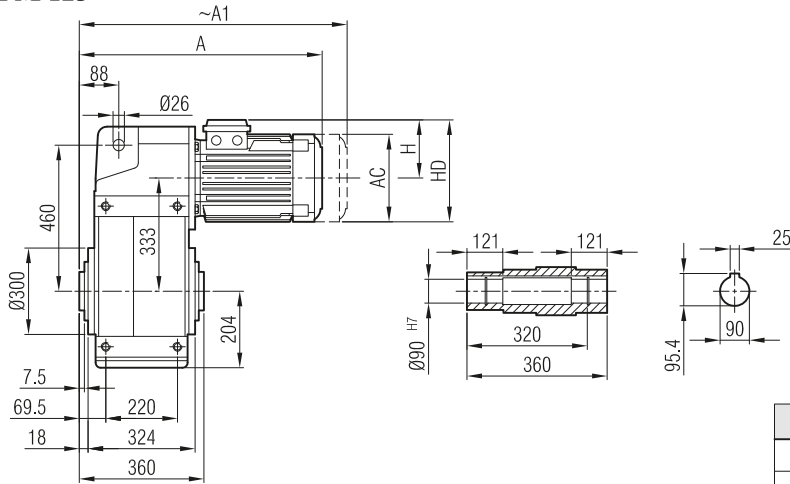

	100	112	132 S	132 M	160 M	160 L	180 M	180 L	200	225 S	225 M
A	621	635	694	732	803	847	876	914	968	1002	1027
A <sub>1</sub>	699	718	794	832	918	962	996	1034	1088	1122	1147
H	134	145	168	168	220	220	241	241	277	285	285
HD	234	257	300	300	380	380	421	421	477	510	510
AC	194	218	257	257	310	310	348	348	390	434	434

**YP 122**  
**YP 123**

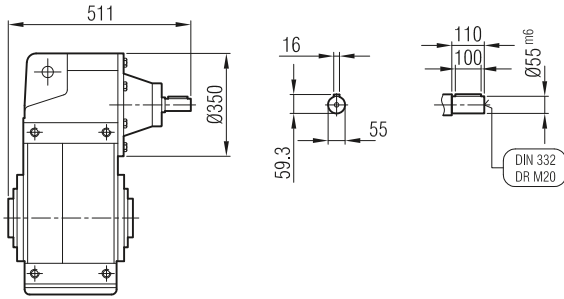

**"A<sub>1</sub>" Ölçüsü Frenli Motorlar içindir.**  
Dimension "A<sub>1</sub>" is for motors with brake.  
Le dimensions "A<sub>1</sub>" correspondent aux moteurs équipés de freins.

**YPPM 122**  
**YPPM 123**

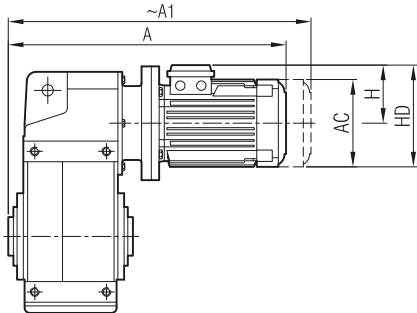

	100/ B5	112/ B5	132 S/ B5	132 M/ B5	160 M/ B5	160 L/ B5	180 M/ B5	180 L/ B5	200/ B5	225 S/ B5	225 M/ B5
A	695	715	786	824	903	947	960	998	1118	1143	1168
A <sub>1</sub>	773	798	886	924	1018	1062	1080	1118	1238	1263	1288
H	134	145	168	168	220	220	241	241	277	285	285
HD	234	257	300	300	380	380	421	421	477	510	510
AC	194	218	257	257	310	310	348	348	390	434	434

**"A<sub>1</sub>" Ölçüsü Frenli Motorlar içindir.**  
Dimension "A<sub>1</sub>" is for motors with brake.  
Le dimensions "A<sub>1</sub>" correspondent aux moteurs équipés de freins.

**YPP 122**  
**YPP 123**

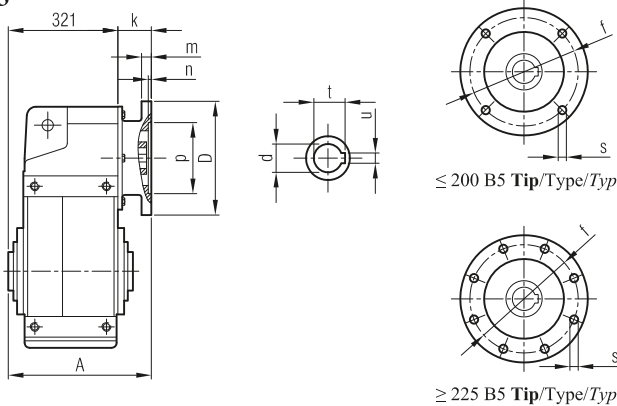

	A	Øp	Øf	ØD	s	k	m	n	Ød	t	u
100/B5	379	180	215	250	M12	57	15	5	28	31.3	8
112/B5	379	180	215	250	M12	57	15	5	28	31.3	8
132/B5	406	230	265	300	M12	84	17	6	38	41.3	10
160/B5	413	250	300	350	M14	91	18	6.5	42	45.3	12
180/B5	413	250	300	350	M14	91	18	6.5	48	51.8	14
200/B5	481	300	350	400	M16	159	20	6.5	55	59.3	16
225/B5	488	350	400	450	M16	166	22	6.5	60	69.4	18





**YPM / YP  
YPPM / YPP**

**... -SL**

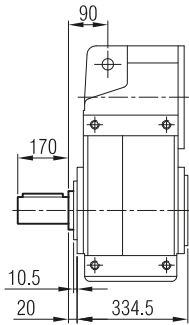

**... -H**

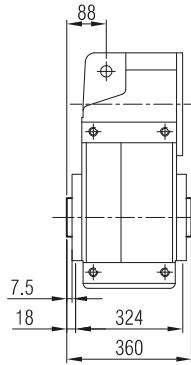

**... -SDL**

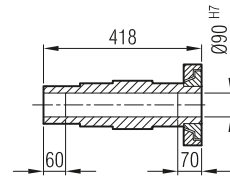
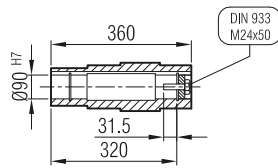
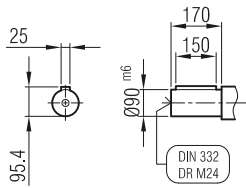
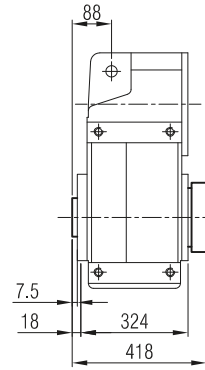

**YPFM / YPF  
YFPFM / YFPF**

**... -FL -SL**

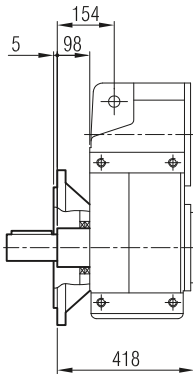

**... -FL**

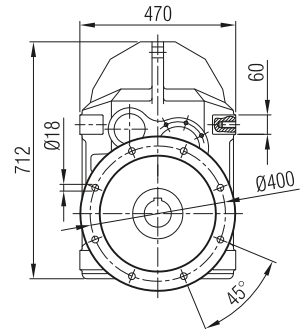
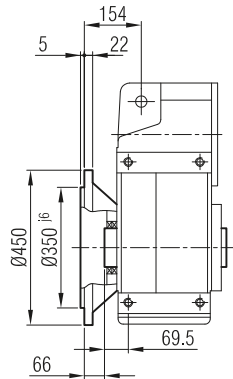

**-TL**

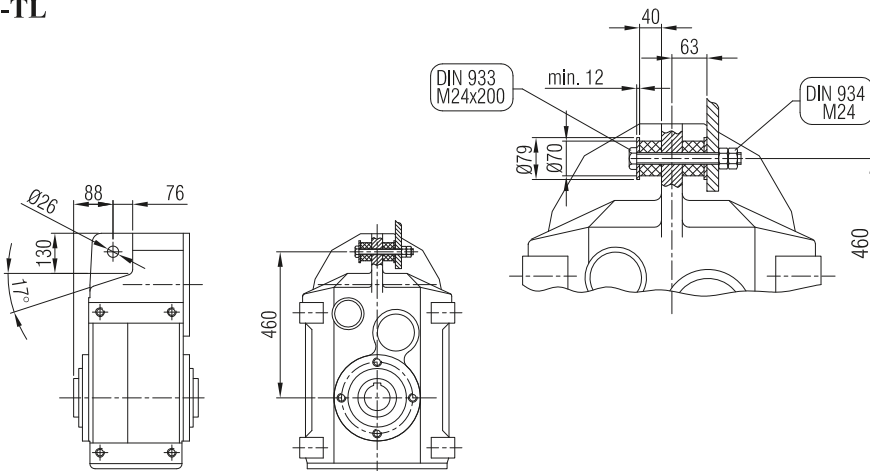

**Klemens Pozisyonları**  
Terminal Box Positions  
Klemenskasten Positionen

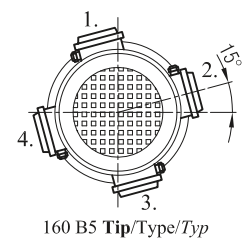
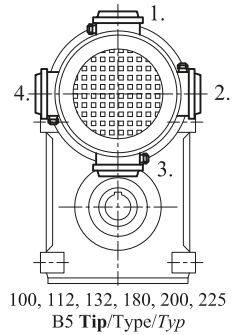



**YPM 124**

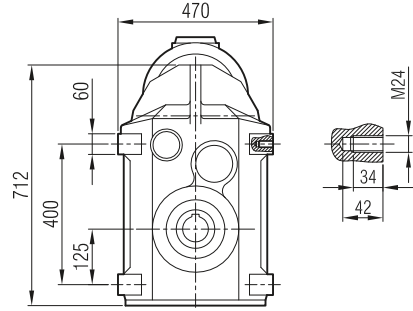
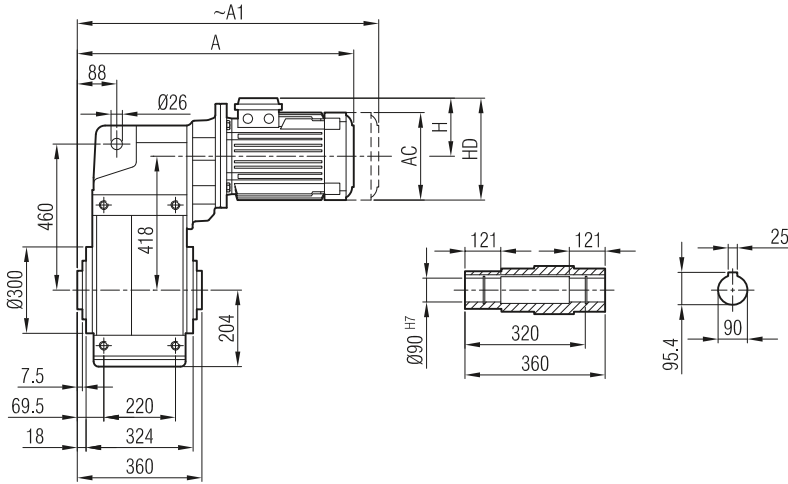

	80	90 S	90 L	100	112	132 S
A	634	662	687	717	740	792
A <sub>1</sub>	703	728	753	795	823	892
H	118	126	126	134	145	168
HD	198	216	216	234	257	300
AC	156	176	176	194	218	257

**YP 124**

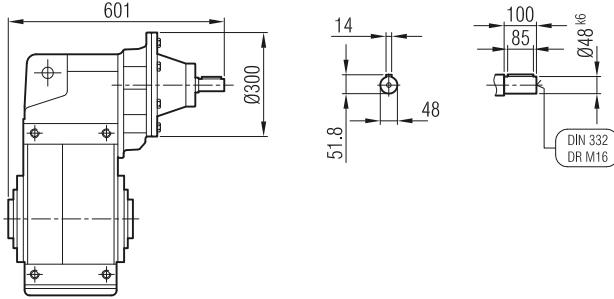

**"A<sub>1</sub>" Ölçüsü Frenli Motorlar içindir.**  
Dimension "A<sub>1</sub>" is for motors with brake.  
Le dimensions "A<sub>1</sub>" correspondent aux moteurs équipés de freins.

**YPPM 124**

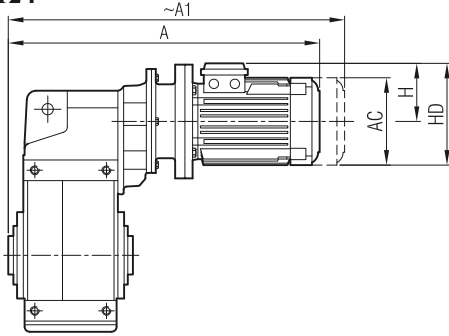

	80/B5	90 S/B5	90 L/B5	100/B5	112/B5	132 S/B5
A	705	720	745	786	806	887
A <sub>1</sub>	774	786	811	864	889	987
H	118	126	126	134	145	168
HD	198	216	216	234	257	300
AC	156	176	176	194	218	257

**"A<sub>1</sub>" Ölçüsü Frenli Motorlar içindir.**  
Dimension "A<sub>1</sub>" is for motors with brake.  
Le dimensions "A<sub>1</sub>" correspondent aux moteurs équipés de freins.

**YPP 124**

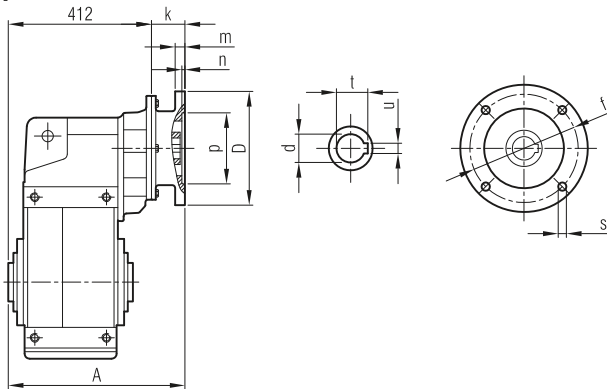

	A	Øp	Øf	ØD	s	k	m	n	Ød	t	u
80/B5	461	130	165	200	M10	67	12	5	19	21.8	6
90/B5	461	130	165	200	M10	67	12	5	24	27.3	8
100/B5	470	180	215	250	M12	74	14	5	28	31.3	8
112/B5	470	180	215	250	M12	74	14	5	28	31.3	8
132/B5	507	230	265	300	M12	95	17	6	38	41.3	10



**YPM / YP  
YPPM / YPP ... -SL**

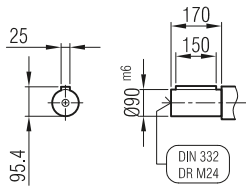
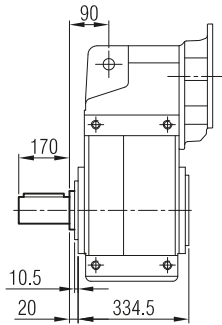

**... -H**

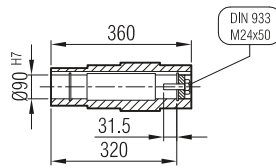
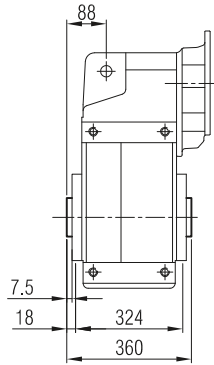

**... -SDL**

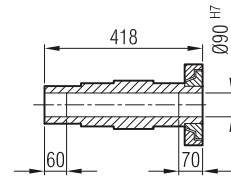
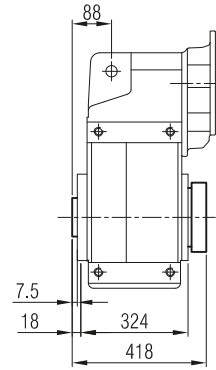

**YPFM / YPF  
YPPFM / YPPF ... -FL -SL**

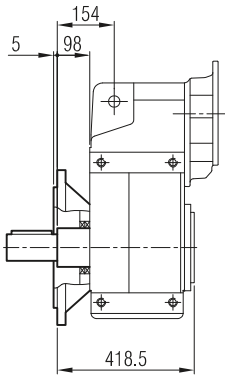

**... -FL**

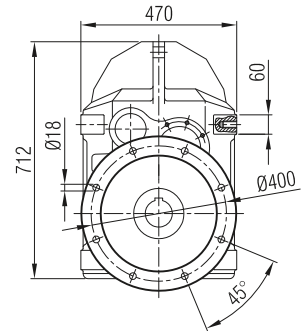
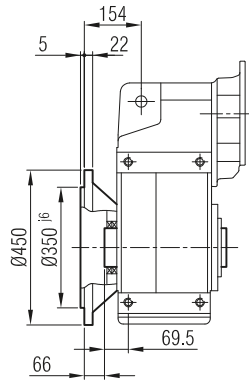

**-TL**

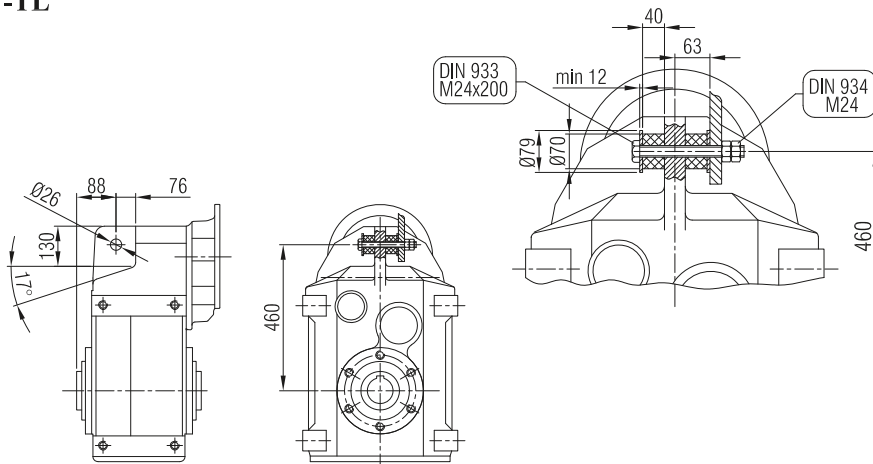

**Klemens Pozisyonları**  
Terminal Box Positions  
Klemenskasten Positionen

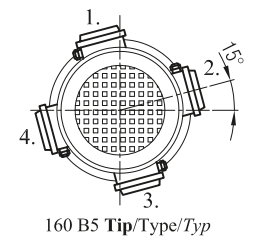
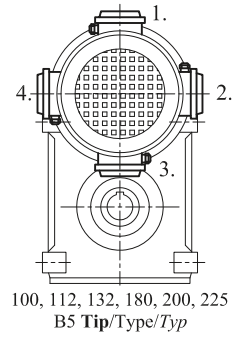



**YPM 123 İR 72**  
**YPM 123 İR 73**

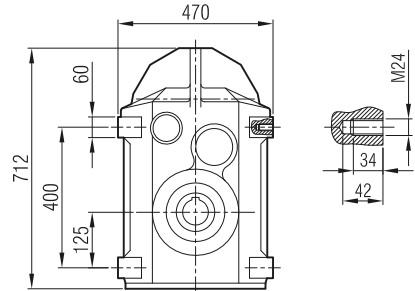
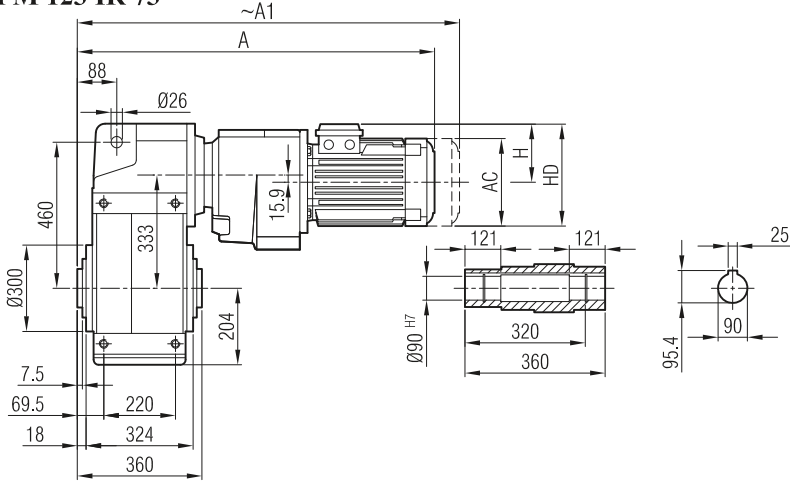

	71	80	90 S	90 L	100	112
A	747	777	807	832	873	896
A <sub>1</sub>	798	846	873	898	951	979
H	111	118	126	126	134	145
HD	182	198	216	216	234	257
AC	138	156	176	176	194	218

**YP 122 İR 72 / YP 122 İR 73**  
**YP 123 İR 72 / YP 123 İR 73**

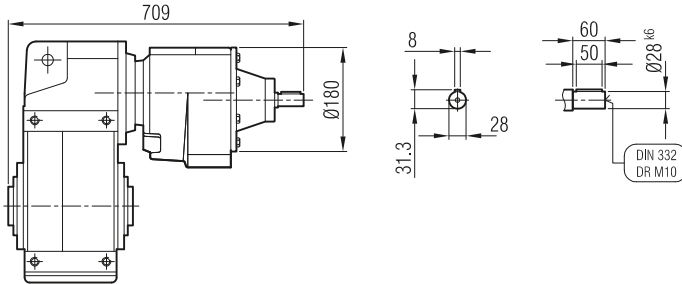

**"A<sub>1</sub>" Ölçüsü Frenli Motorlar içindir.**  
Dimension "A<sub>1</sub>" is for motors with brake.  
Le dimensions "A<sub>1</sub>" correspondent aux moteurs équipés de freins.

**YPPM 123 İR 72**  
**YPPM 123 İR 73**

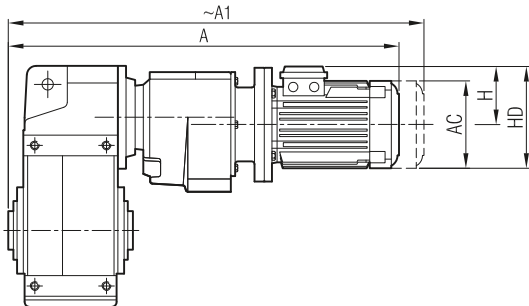

	71/B5	80/B5	90 S/B5	90 L/B5	100/B5	112/B5
A	823	856	871	896	933	953
A <sub>1</sub>	874	925	937	962	1011	1036
H	111	118	126	126	134	145
HD	182	198	216	216	234	257
AC	138	156	176	176	194	218

**"A<sub>1</sub>" Ölçüsü Frenli Motorlar içindir.**  
Dimension "A<sub>1</sub>" is for motors with brake.  
Le dimensions "A<sub>1</sub>" correspondent aux moteurs équipés de freins.

**YPP 123 İR 72**  
**YPP 123 İR 73**

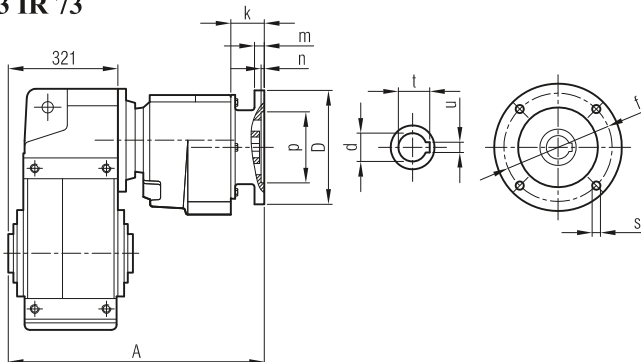

	A	Øp	Øf	ØD	s	k	m	n	Ød	t	u
71/B5	590	110	130	160	M8	55	10	4	14	16.3	5
80/B5	602	130	165	200	M10	67	12	5	19	21.8	6
90/B5	602	130	165	200	M10	67	12	5	24	27.3	8
100/B5	607	180	215	250	M12	71.5	14	5	28	31.3	8
112/B5	607	180	215	250	M12	71.5	14	5	28	31.3	8



**YPM / YP  
YPPM / YPP**

**... -SL**

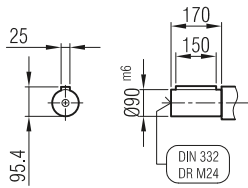
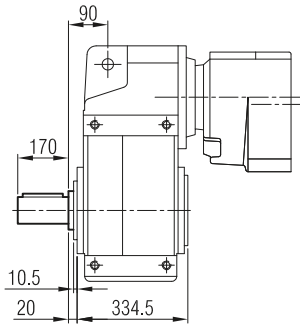

**... -H**

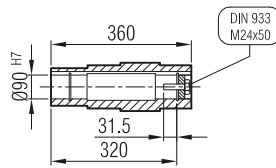
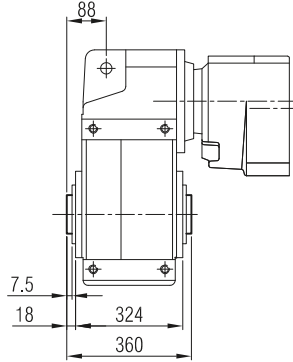

**... -SDL**

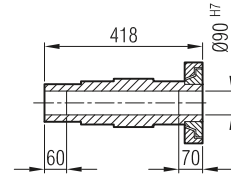
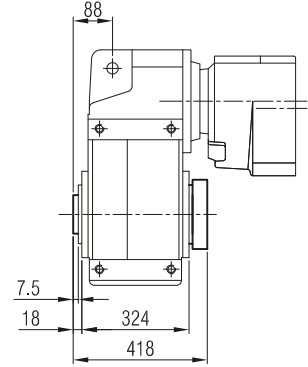

**YPFM / YPF  
YPPFM / YPPF**

**... -FL -SL**

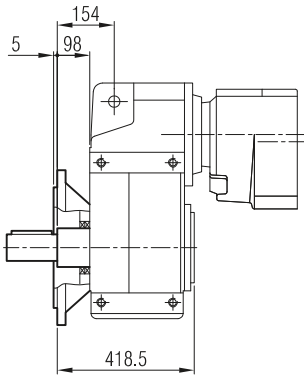

**... -FL**

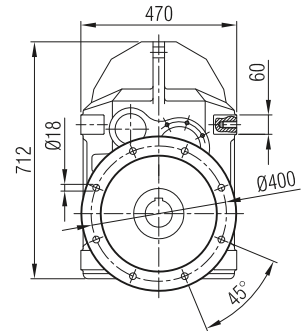
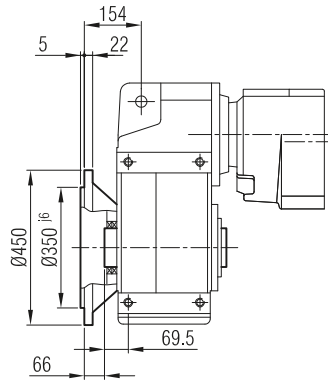

**-TL**

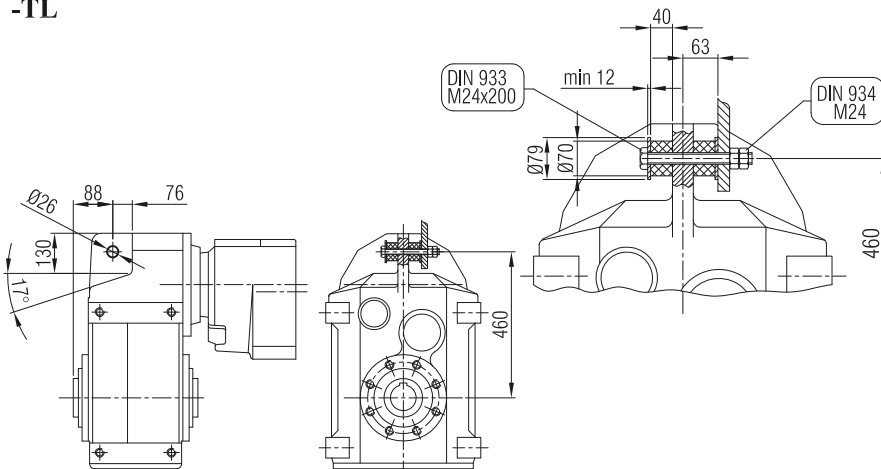

**Klemens Pozisyonları**  
Terminal Box Positions  
Klemenskasten Positionen

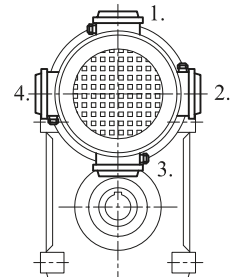

100, 112, 132, 180, 200, 225  
B5 Tip/Type/Typ

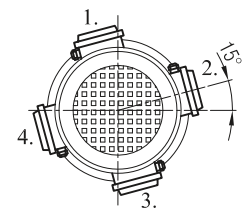

160 B5 Tip/Type/Typ



**YPM 142**  
**YPM 143**

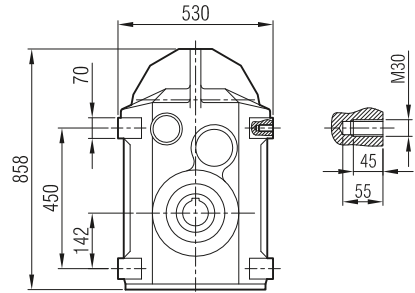
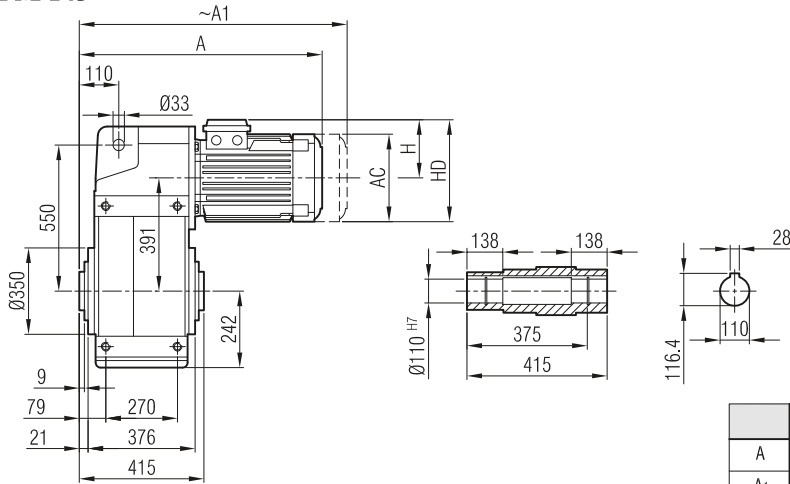

	132 S	132 M	160 M	160 L	180 M	180 L	200	225 S	225 M	250 M	280 S	280 M
A	707	745	850	894	907	945	996	1029	1054	1132	1193	1193
A <sub>1</sub>	807	845	965	1009	1027	1065	1116	1149	1174	1252	1313	1393
H	168	168	220	220	241	241	277	285	285	322	350	350
HD	300	300	380	380	421	421	477	510	510	572	630	630
AC	257	257	310	310	348	348	390	434	434	480	544	544

**YP 142**  
**YP 143**

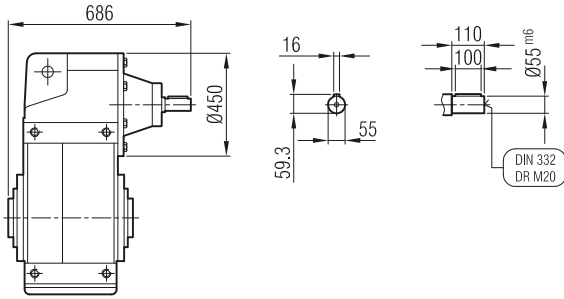

"A<sub>1</sub>" Ölçüsü Frenli Motorlar içindir.  
Dimension "A<sub>1</sub>" is for motors with brake.  
Le dimensions "A<sub>1</sub>" correspondent aux moteurs équipés de freins.

**YPPM 142**  
**YPPM 143**

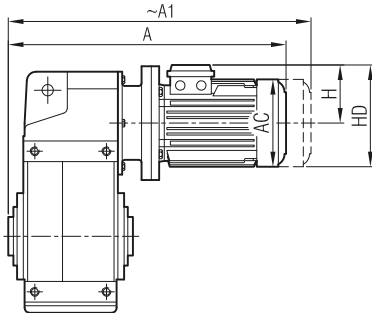

	132 S/B5	132 M/B5	160 M/B5	160 L/B5	180 M/B5	180 L/B5	200/B5	225 S/B5	225 M/B5	250/B5	280 S/B5	280 M/B5
A	816	854	951	995	1008	1046	1166	1193	1218	1294	1356	1356
A <sub>1</sub>	916	954	1066	1110	1128	1166	1286	1313	1338	1414	1476	1556
H	168	168	220	220	241	241	277	285	285	322	350	350
HD	300	300	380	380	421	421	477	510	510	572	630	630
AC	257	257	310	310	348	348	390	434	434	480	544	544

"A<sub>1</sub>" Ölçüsü Frenli Motorlar içindir.  
Dimension "A<sub>1</sub>" is for motors with brake.  
Le dimensions "A<sub>1</sub>" correspondent aux moteurs équipés de freins.

**YPP 142**  
**YPP 143**

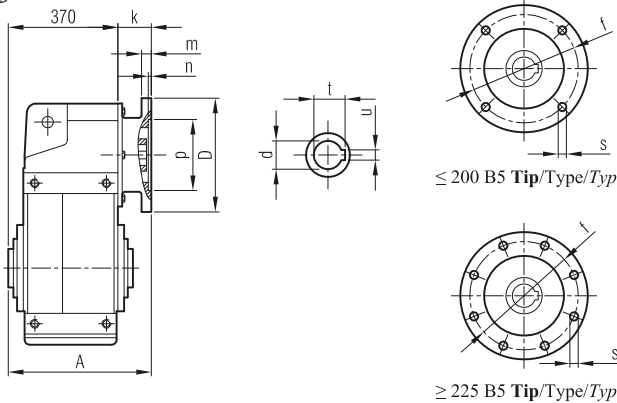

	A	Øp	Øf	ØD	s	k	m	n	Ød	t	u
132/B5	436	230	265	300	M12	61	17	6	38	41.3	10
160/B5	461	250	300	350	M14	91	18	6.5	42	45.3	12
180/B5	461	250	300	350	M14	91	18	6.5	48	51.8	14
200/B5	529	300	350	400	M16	159	20	6.5	55	59.3	16
225/B5	538	350	400	450	M16	168	22	6.5	60	64.4	18
250/B5	538	450	500	550	M16	168	22	6.5	65	69.4	18
280/B5	538	450	500	550	M16	168	22	6.5	75	75.9	20



**YPM / YP  
YPPM / YPP**

**... -SL**

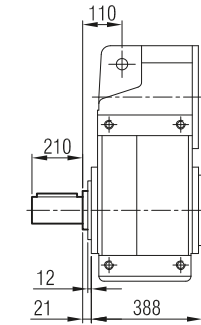

**... -H**

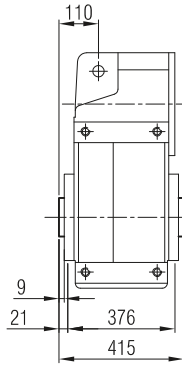

**... -SDL**

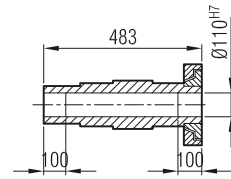
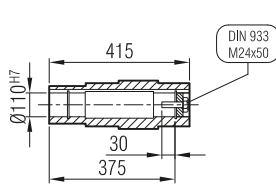
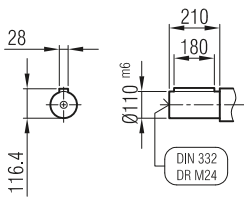
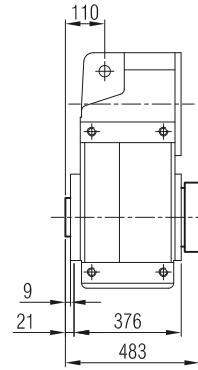

**YPFM / YPF  
YPFPM / YPF**

**... -FL -SL**

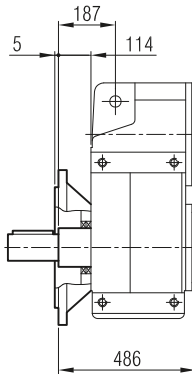

**... -FL**

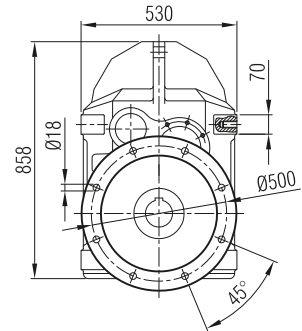
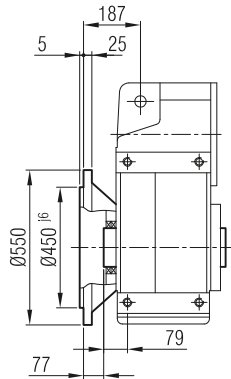

**-TL**

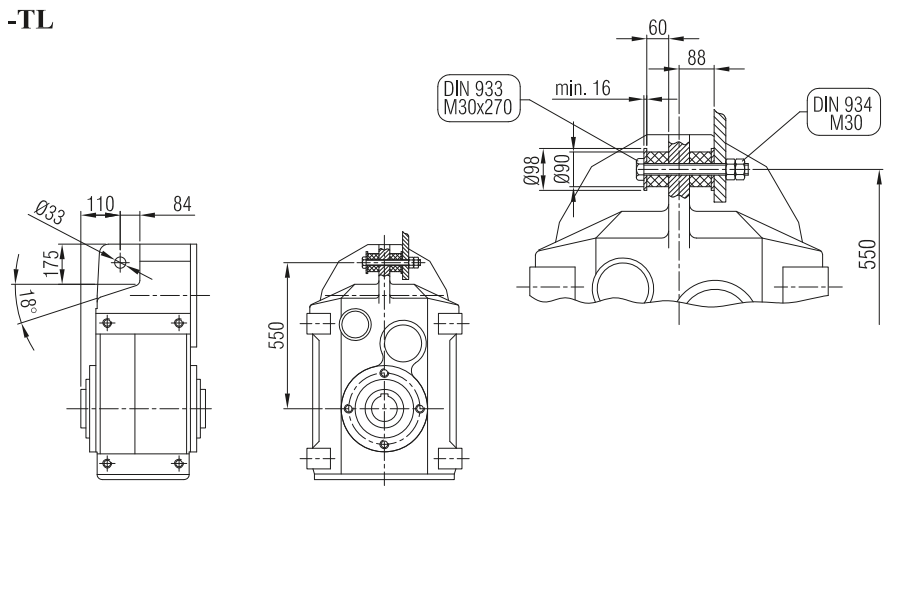

**Klemens Pozisyonları**  
Terminal Box Positions  
Klemenskasten Positionen

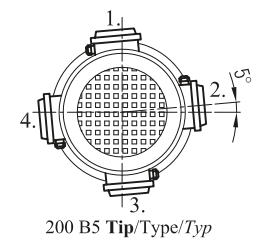
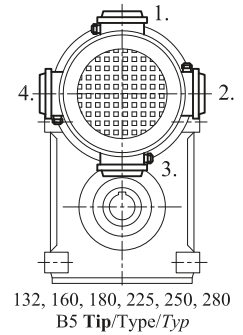



**YPM 144**

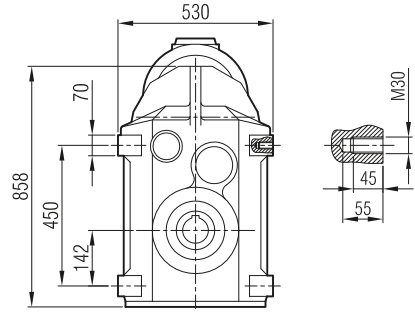
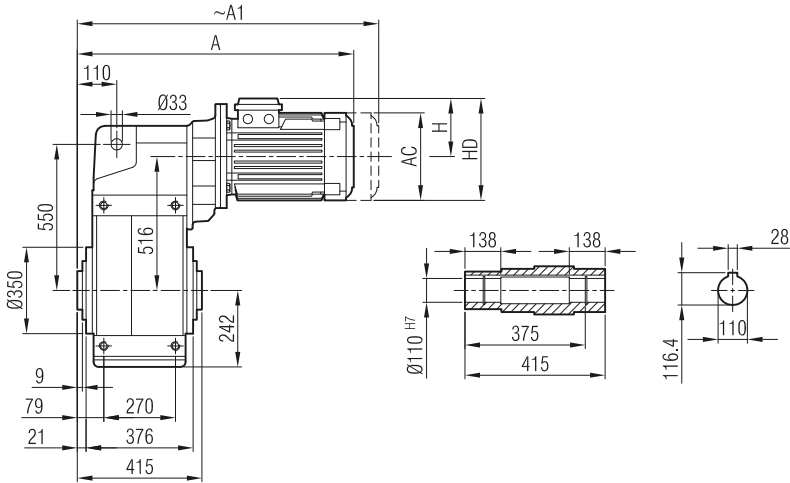

	100	112	132 S	132 M	160 M	160 L
A	801	821	862	900		
A <sub>1</sub>	879	904	962	1000		
H	134	145	168	168		
HD	234	257	300	300		
AC	194	218	257	257		

**YP 144**

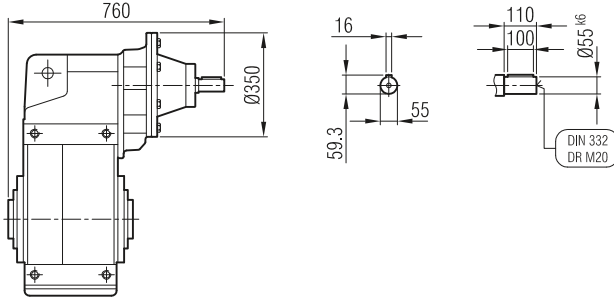

**"A<sub>1</sub>" Ölçüsü Frenli Motorlar içindir.**  
Dimension "A<sub>1</sub>" is for motors with brake.  
*Le dimensions "A<sub>1</sub>" correspond aux moteurs équipés de freins.*

**YPPM 144**

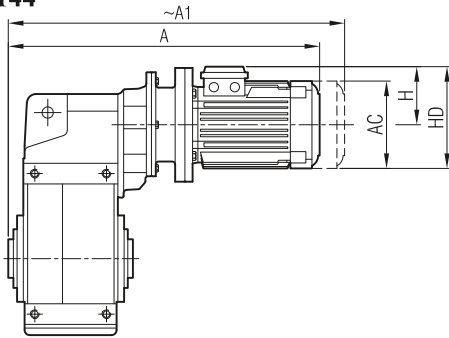

	100/B5	112/B5	132 S/B5	132 M/B5
A	863	883	954	992
A <sub>1</sub>	941	966	1054	1092
H	134	145	168	168
HD	234	257	300	300
AC	194	218	257	257

**"A<sub>1</sub>" Ölçüsü Frenli Motorlar içindir.**  
Dimension "A<sub>1</sub>" is for motors with brake.  
*Le dimensions "A<sub>1</sub>" correspond aux moteurs équipés de freins.*

**YPP 144**

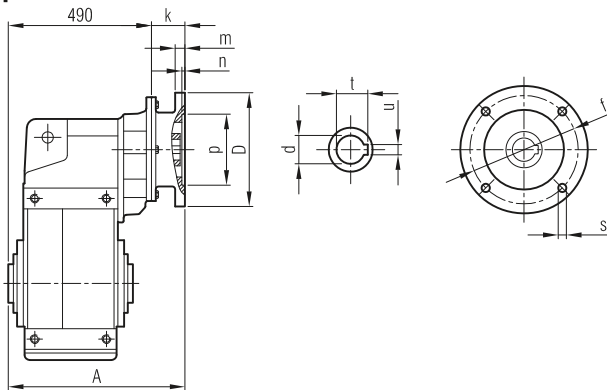

	A	Øp	Øf	ØD	s	k	m	n	Ød	t	u
100/B5	547	180	215	250	M12	57	15	5	28	31.3	8
112/B5	547	180	215	250	M12	57	15	5	28	31.3	8
132/B5	574	230	265	300	M14	84	17	6	38	41.3	10





**YPM / YP**  
**YPPM / YPP**

**... -SL**

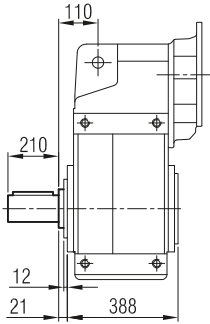

**... -H**

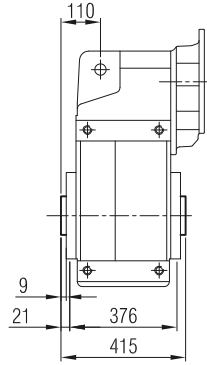

**... -SDL**

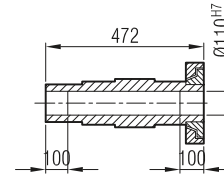
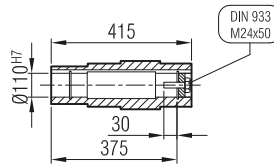
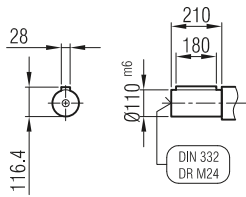
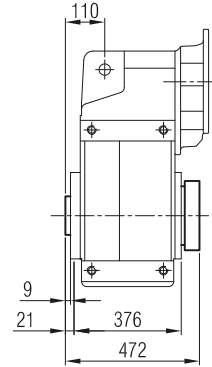

**YPFM / YPF**  
**YFPFM / YFPF**

**... -FL -SL**

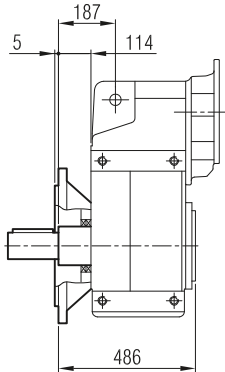

**... -FL**

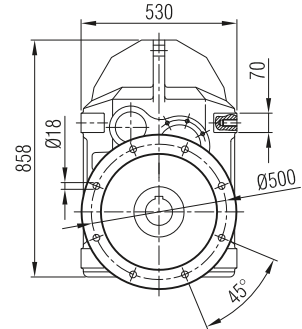
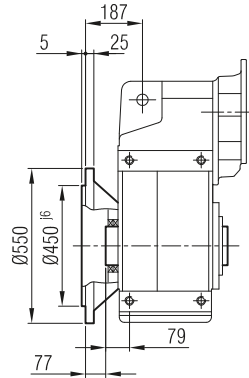

**-TL**

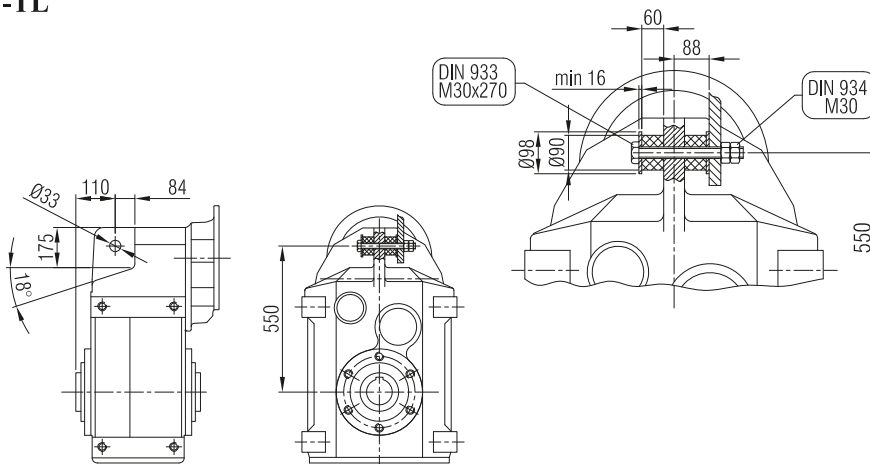

**Klemens Pozisyonları**  
Terminal Box Positions  
Klemenskasten Positionen

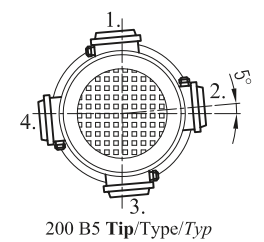
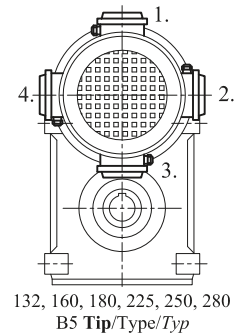



**YPM 143 İR 72**  
**YPM 143 İR 73**

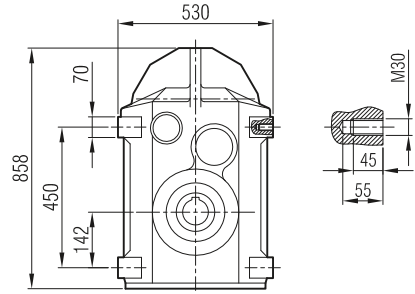
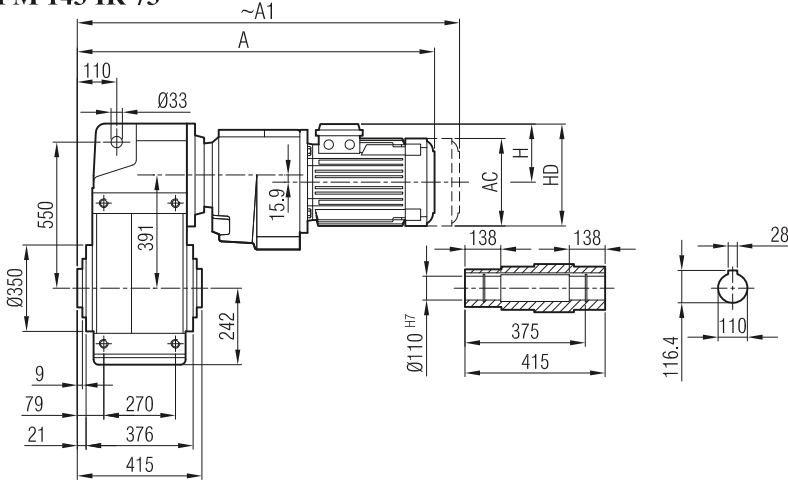

	71	80	90 S	90 L	100	112	132 S
A	795	825	855	880	921	944	1006
A <sub>1</sub>	846	894	921	946	999	1027	1106
H	111	118	126	126	134	145	168
HD	182	198	216	216	234	257	300
AC	138	156	176	176	194	218	257

**YP 142 İR 72 / YP 142 İR 73**  
**YP 143 İR 72 / YP 143 İR 73**

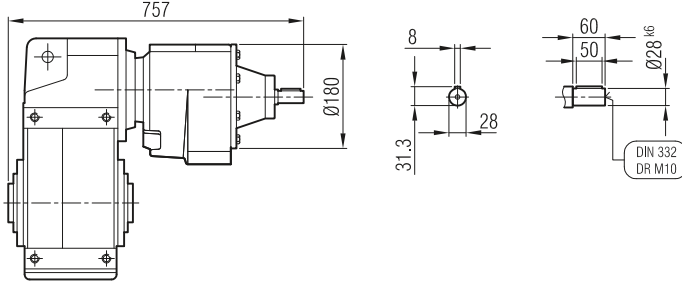

**"A<sub>1</sub>" Ölçüsü Frenli Motorlar içindir.**  
Dimension "A<sub>1</sub>" is for motors with brake.  
Le dimensions "A<sub>1</sub>" correspondent aux moteurs équipés de freins.

**YPPM 143 İR 72**  
**YPPM 143 İR 73**

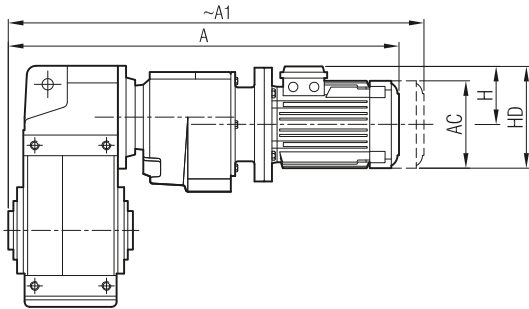

	71/B5	80/B5	90 S/B5	90 L/B5	100/B5	112/B5	132 S/B5
A	871	904	919	944	981	1001	1069
A <sub>1</sub>	922	973	985	1010	1059	1084	1169
H	111	118	126	126	134	145	168
HD	182	198	216	216	234	257	300
AC	138	156	176	176	194	218	257

**"A<sub>1</sub>" Ölçüsü Frenli Motorlar içindir.**  
Dimension "A<sub>1</sub>" is for motors with brake.  
Le dimensions "A<sub>1</sub>" correspondent aux moteurs équipés de freins.

**YPP 143 İR 72**  
**YPP 143 İR 73**

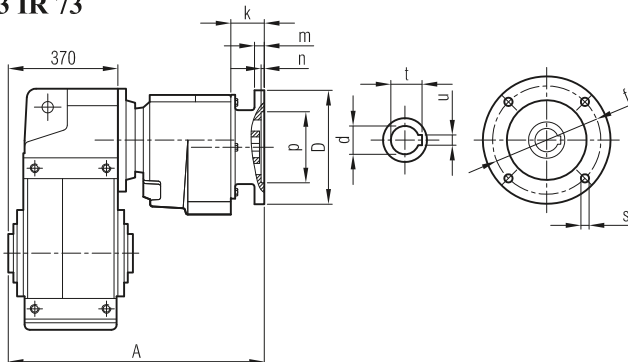

	A	Øp	Øf	ØD	s	k	m	n	Ød	t	u
71/B5	648	110	130	160	M8	55	10	4	14	16.3	5
80/B5	660	130	165	200	M10	67	12	5	19	21.8	6
90/B5	660	130	165	200	M10	67	12	5	24	27.3	8
100/B5	665	180	215	250	M12	71.5	14	5	28	31.3	8
112/B5	665	180	215	250	M12	71.5	14	5	28	31.3	8
132/B5	689	230	265	300	M12	95	17	5	38	41.3	10



**YPM / YP  
YPPM / YPP**

**... -SL**

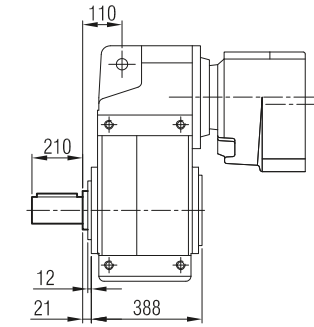

**... -H**

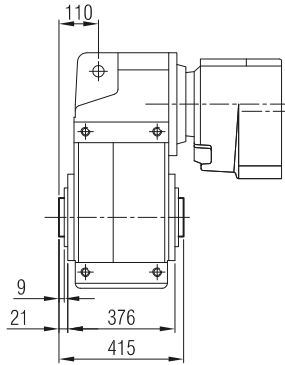

**... -SDL**

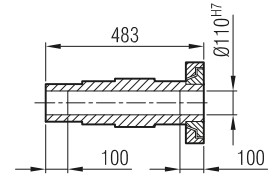
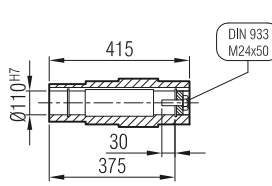
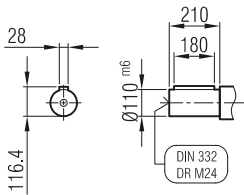
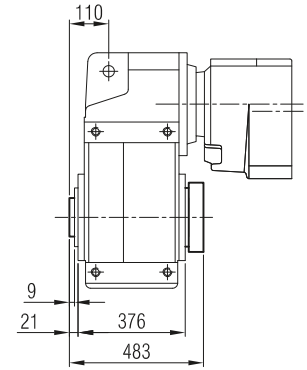

**YPFM / YPF  
YFPFM / YFPF**

**... -FL -SL**

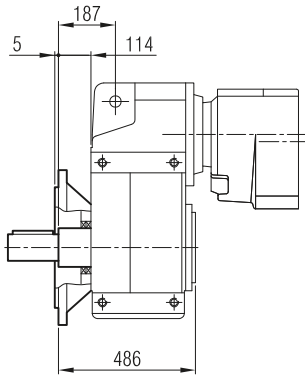

**... -FL**

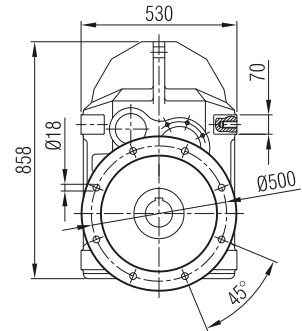
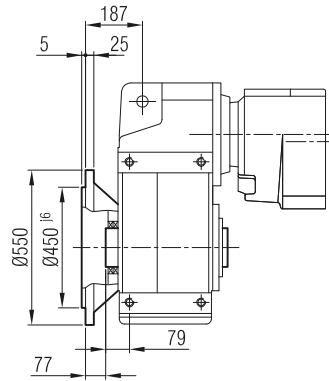

**-TL**

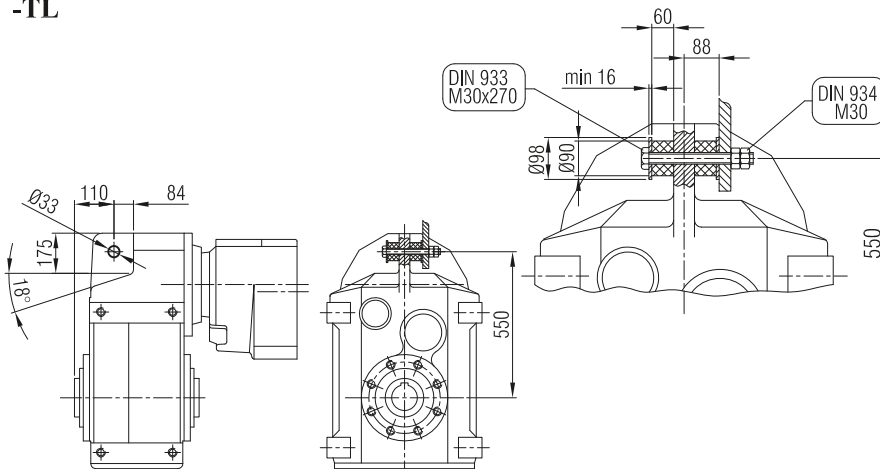

**Klemens Pozisyonları**  
Terminal Box Positions  
Klemenskasten Positionen

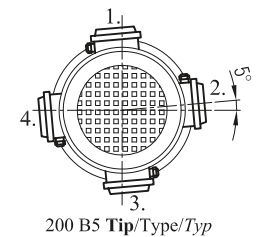
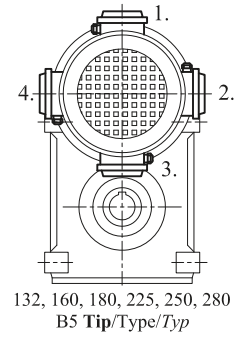



**YPM 143 İR 82**

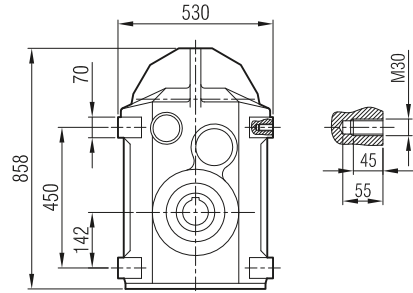
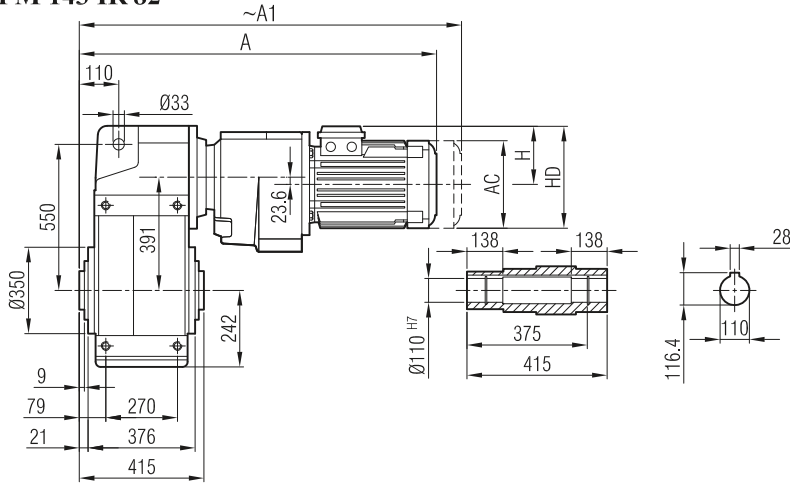

	112	132 S	132 M	160 M	160 L
A	874	902	927	967	989
A <sub>1</sub>	943	968	993	1045	1072
H	145	168	168	220	220
HD	257	300	300	380	380
AC	218	257	257	310	310

**YP 143 İR 82**

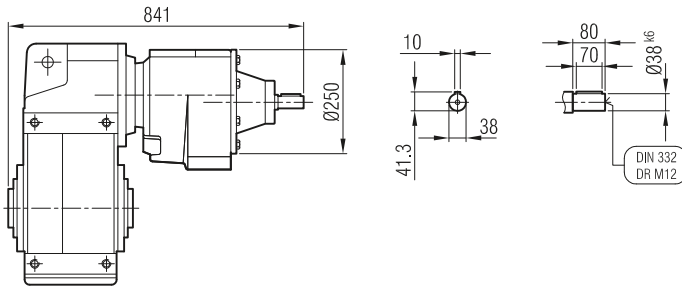

**"A<sub>1</sub>" Ölçüsü Frenli Motorlar içindir.**  
Dimension "A<sub>1</sub>" is for motors with brake.  
Le dimensions "A<sub>1</sub>" correspond aux moteurs équipés de freins.

**YPPM 143 İR 82**

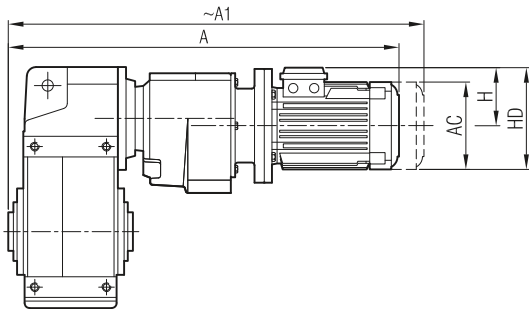

	112/B5	132 S/B5	132 M/B5	160 M/B5	160 L/B5
A	962	977	1002	1042	1062
A <sub>1</sub>	1031	1043	1068	1120	1145
H	145	168	168	220	220
HD	257	300	300	380	380
AC	218	257	257	310	310

**"A<sub>1</sub>" Ölçüsü Frenli Motorlar içindir.**  
Dimension "A<sub>1</sub>" is for motors with brake.  
Le dimensions "A<sub>1</sub>" correspond aux moteurs équipés de freins.

**YPP 143 İR 82**

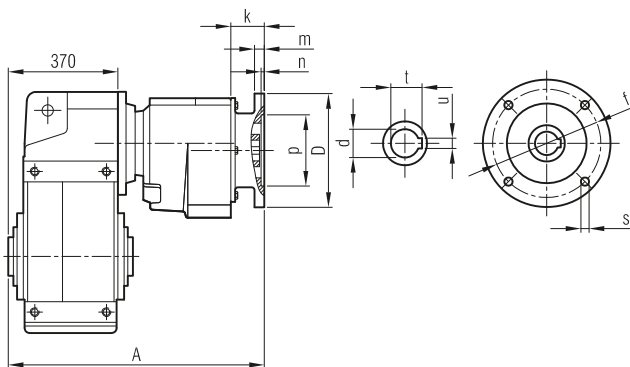

	A	Øp	Øf	ØD	s	k	m	n	Ød	t	u
112/B5	726	180	215	250	M12	74	14	5	28	31.3	8
132/B5	747	230	265	300	M12	95	17	6	38	41.3	10
160/B5	763	250	300	350	M14	111	18	6.5	42	45.3	12



**YPM / YP  
YPPM / YPP**

**... -SL**

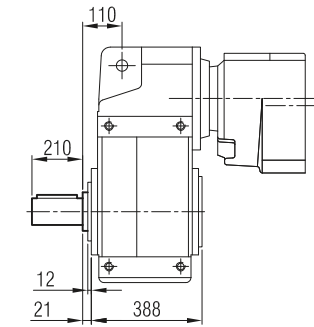

**... -H**

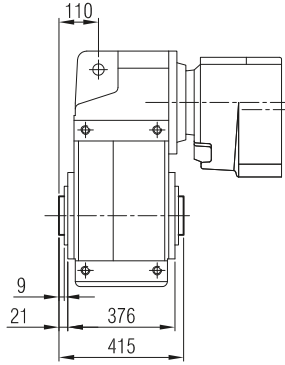

**... -SDL**

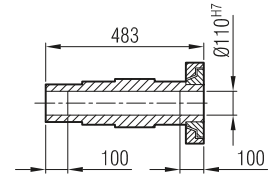
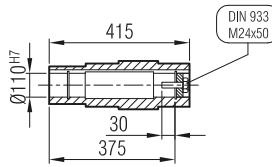
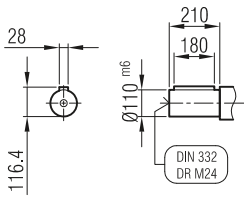
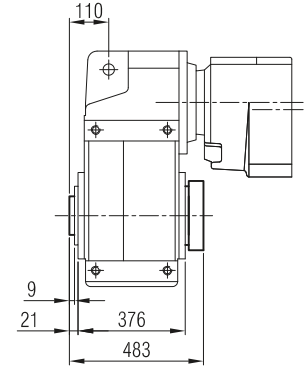

**YPFM / YPF  
YFPFM / YFPF**

**... -FL -SL**

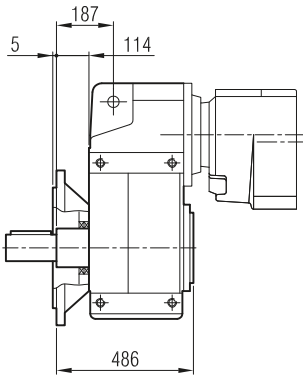

**... -FL**

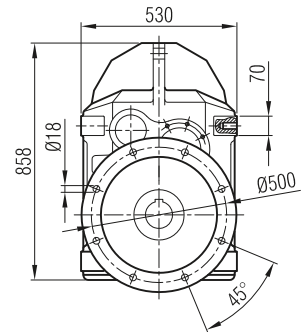
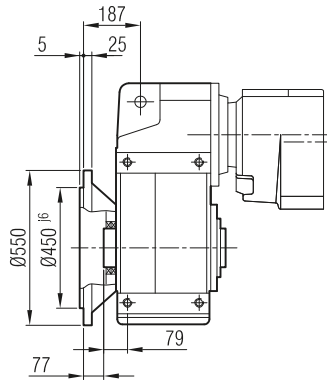

**-TL**

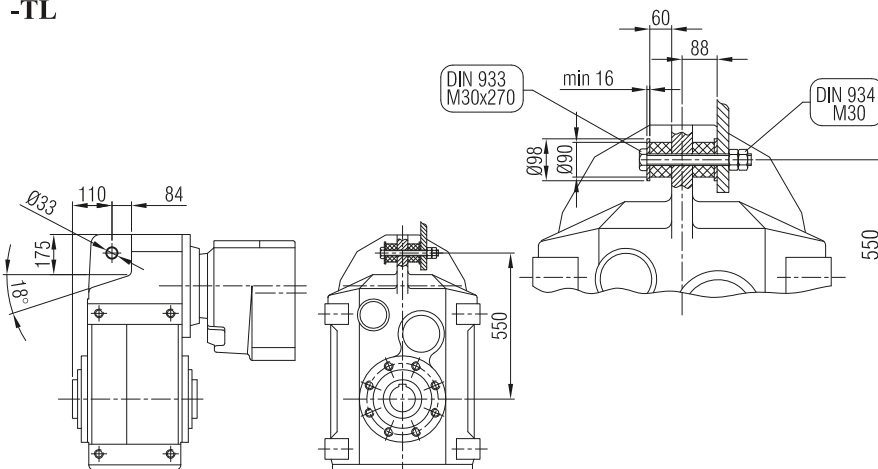

**Klemens Pozisyonları  
Terminal Box Positions  
Klemenskasten Positionen**

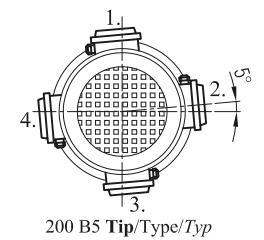
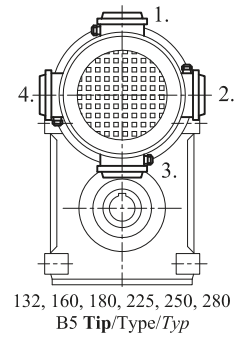



**YPM 152**  
**YPM 153**

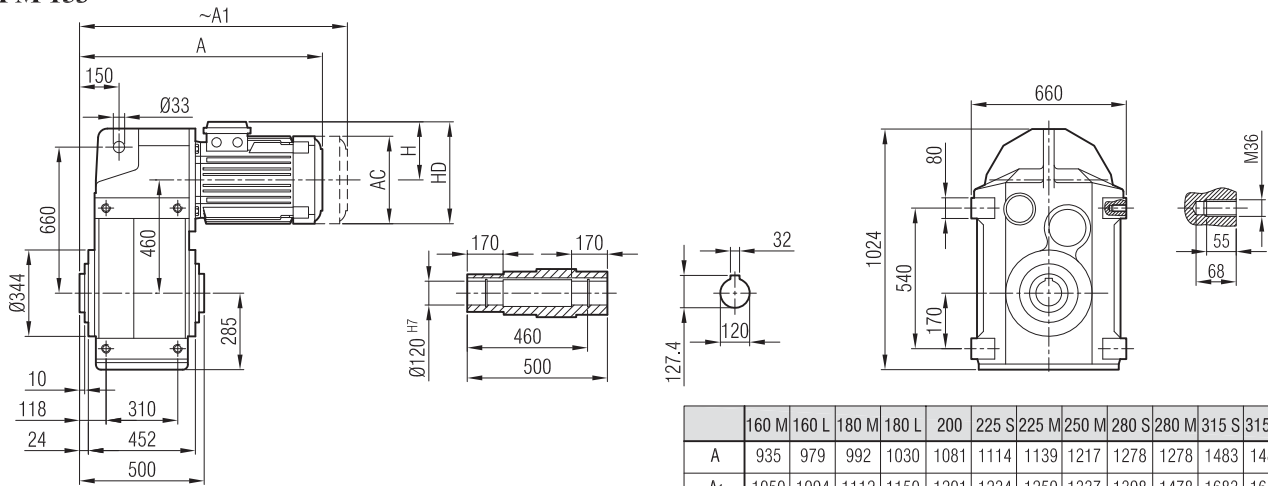

	160 M	160 L	180 M	180 L	200	225 S	225 M	250 M	280 S	280 M	315 S	315 M	315 L
A	935	979	992	1030	1081	1114	1139	1217	1278	1278	1483	1483	1553
A <sub>1</sub>	1050	1094	1112	1150	1201	1234	1259	1337	1398	1478	1683	1683	1753
H	220	220	241	241	277	285	285	322	350	350	510	510	510
HD	380	380	421	421	477	510	510	572	630	630	825	825	825
AC	310	310	348	348	390	434	434	480	544	544	614	614	614

**YP 152**  
**YP 153**

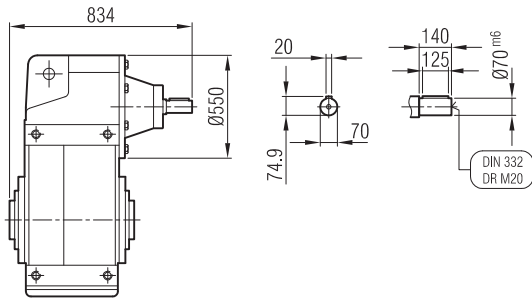

**"A<sub>1</sub>" Ölçüsü Frenli Motorlar içindir.**  
Dimension "A<sub>1</sub>" is for motors with brake.  
Le dimensions "A<sub>1</sub>" correspondent aux moteurs équipés de freins.

**YPPM 152**  
**YPPM 153**

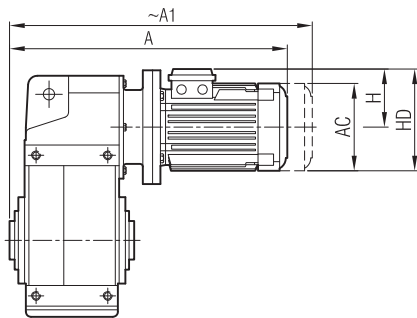

	160 M/B5	160 L/B5	180 M/B5	180 L/B5	200/B5	225 S/B5	225 M/B5	250/B5
A	1036	1080	1093	1131	1251	1278	1303	1379
A <sub>1</sub>	1111	1155	1173	1211	1331	1358	1383	1459
H	220	220	241	241	277	285	285	322
HD	380	380	421	421	477	510	510	572
AC	310	310	348	348	390	434	434	480
	280 S/B5	280 M/B5	315 S/B5	315 M/B5	315 L/B5			
A	1441	1441	1673	1673	1743			
A <sub>1</sub>	1521	1601	1833	1833	2060			
H	350	350	510	510	510			
HD	630	630	825	825	825			
AC	544	544	614	614	614			

**"A<sub>1</sub>" Ölçüsü Frenli Motorlar içindir.**  
Dimension "A<sub>1</sub>" is for motors with brake.  
Le dimensions "A<sub>1</sub>" correspondent aux moteurs équipés de freins.

**YPP 152**  
**YPP 153**

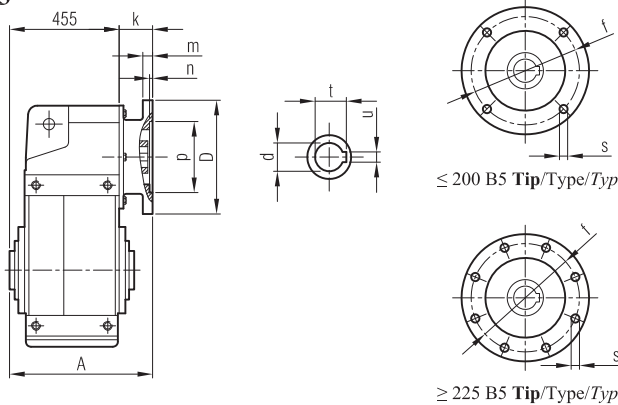

	A	Øp	Øf	ØD	s	k	m	n	Ød	t	u
160/B5	546	250	300	350	M14	91	18	6.5	42	45.3	12
180/B5	546	250	300	350	M14	91	18	6.5	48	51.8	14
200/B5	614	300	350	400	M16	159	20	6.5	55	59.3	16
225/B5	623	350	400	450	M16	168	22	6.5	60	64.4	18
250/B5	623	450	500	550	M16	168	22	6.5	65	69.4	18
280/B5	623	450	500	550	M16	168	22	6.5	75	75.9	20
315/B5	693	550	600	660	M24	238	24	7.5	85	90.4	22



**YPM / YP  
YPPM / YPP**

**... -SL**

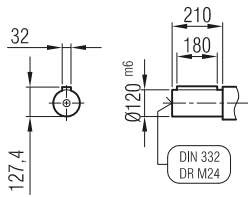
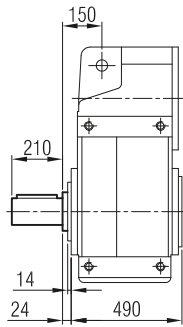

**... -H**

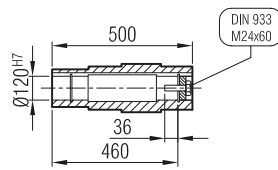
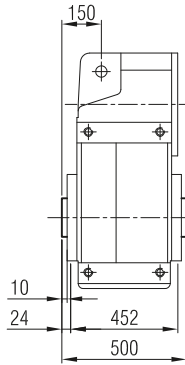

**... -SDL**

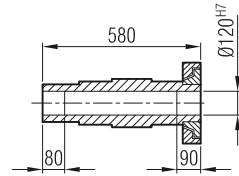
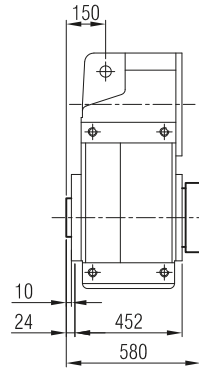

**YPFM / YPF  
YPFPM / YFPF**

**... -FL -SL**

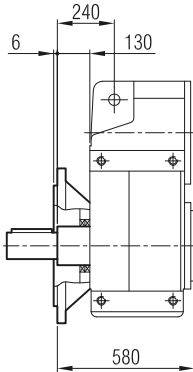

**... -FL**

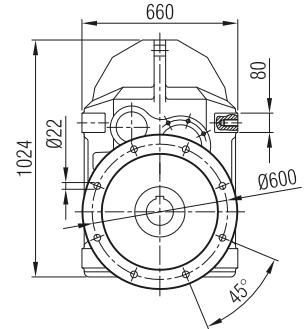
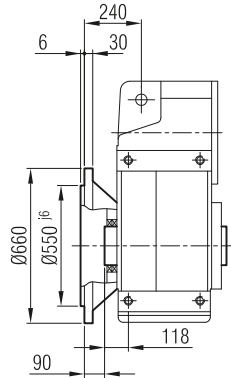

**-TL**

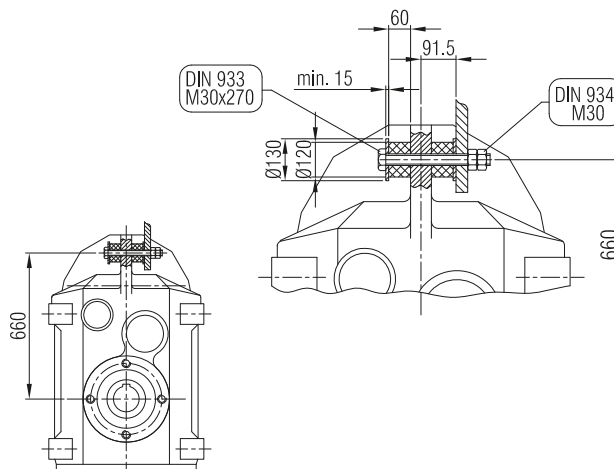
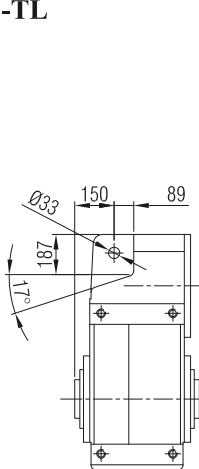

**Klemens Pozisyonları  
Terminal Box Positions  
Klemenskasten Positionen**

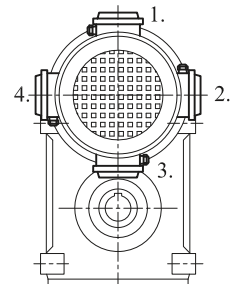



**YPM 154**

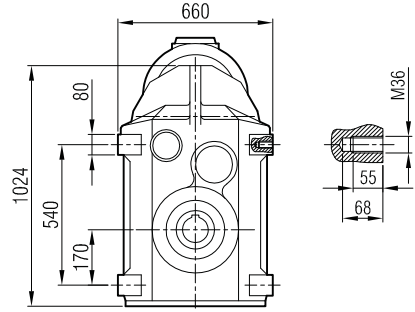
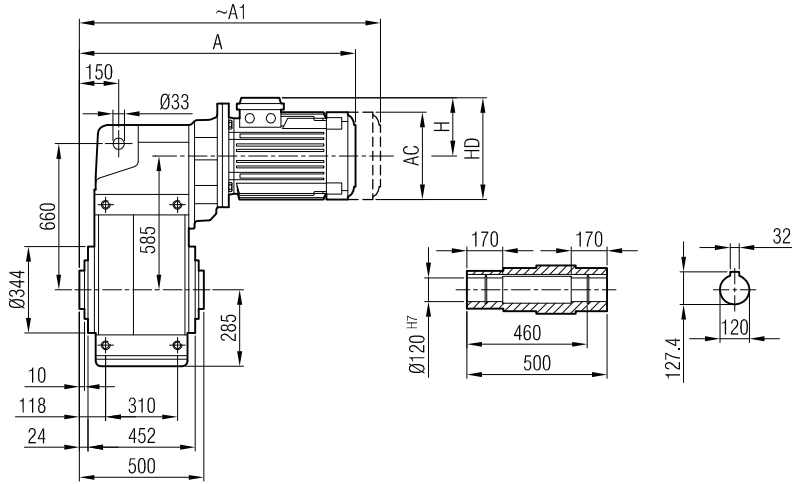

	100	112	132 S	132 M	160 M	160 L
A	851	871	912	950		
A <sub>1</sub>	929	954	1012	1050		
H	134	145	168	168		
HD	234	257	300	300		
AC	194	218	257	257		

**YP 154**

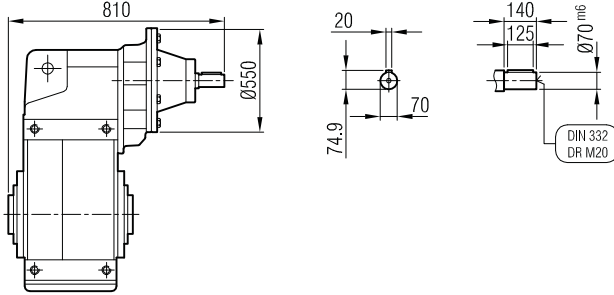

**"A<sub>1</sub>" Ölçüsü Frenli Motorlar içindir.**  
Dimension "A<sub>1</sub>" is for motors with brake.  
*Le dimensions "A<sub>1</sub>" correspondent aux moteurs équipés de freins.*

**YPPM 154**

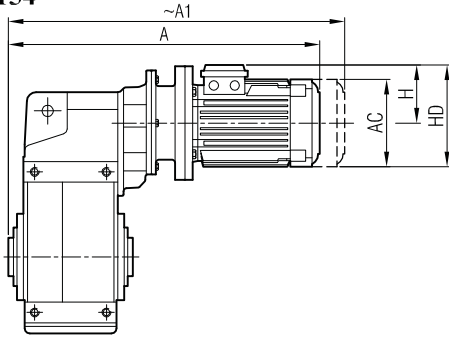

	100/B5	112/B5	132 S/B5	132 M/B5
A	913	933	1004	1042
A <sub>1</sub>	991	1016	1104	1142
H	134	145	168	168
HD	234	257	300	300
AC	194	218	257	257

**"A<sub>1</sub>" Ölçüsü Frenli Motorlar içindir.**  
Dimension "A<sub>1</sub>" is for motors with brake.  
*Le dimensions "A<sub>1</sub>" correspondent aux moteurs équipés de freins.*

**YPP 154**

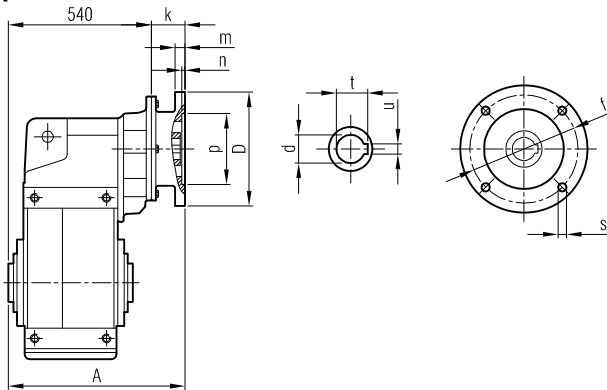

	A	Øp	Øf	ØD	s	k	m	n	Ød	t	u
100/B5	597	180	215	250	M12	57	15	5	28	31.3	8
112/B5	597	180	215	250	M12	57	15	5	28	31.3	8
132/B5	624	230	265	300	M14	84	17	6	38	41.3	10





**YPM / YP  
YPPM / YPP** ... -SL

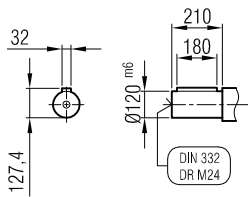
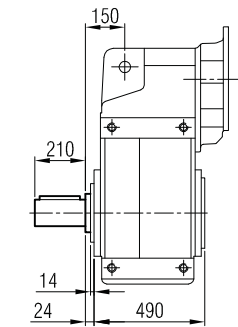

... -H

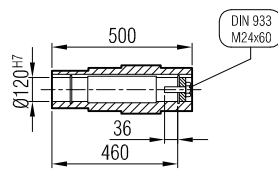
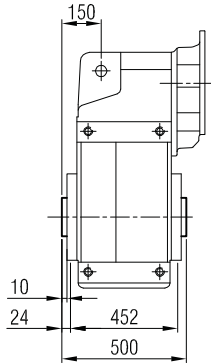

... -SDL

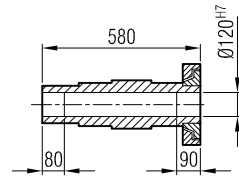
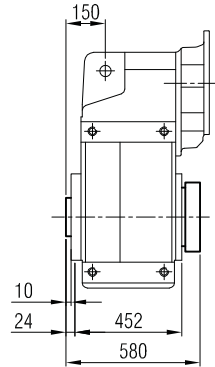

**YPFM / YPF  
YPFPM / YFPF** ... -FL -SL

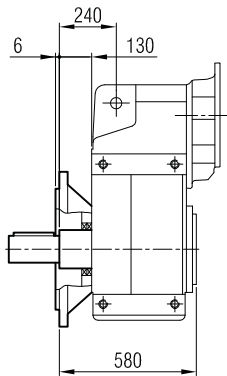

... -FL

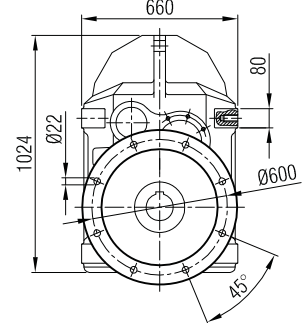
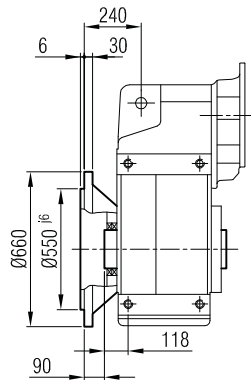

**-TL**

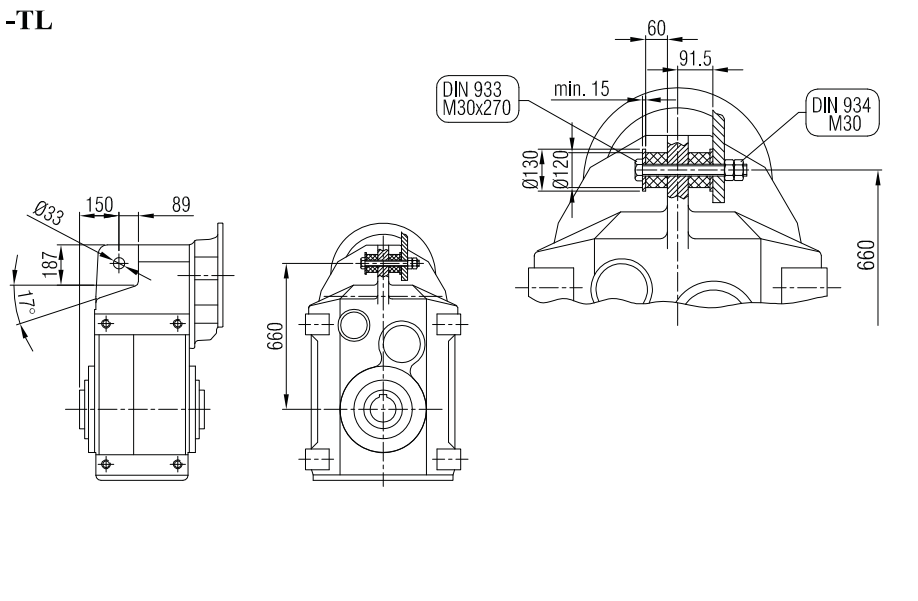

**Klemens Pozisyonları**  
Terminal Box Positions  
Klemenskasten Positionen

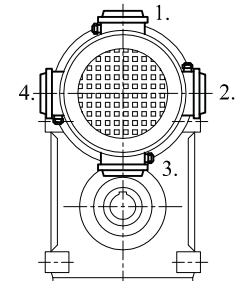



**YPM 152 İR 83**  
**YPM 153 İR 83**

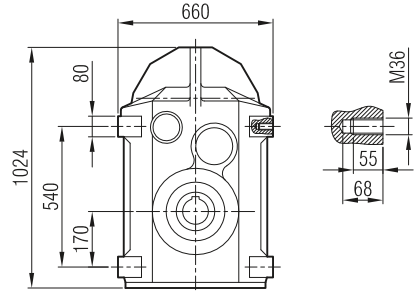
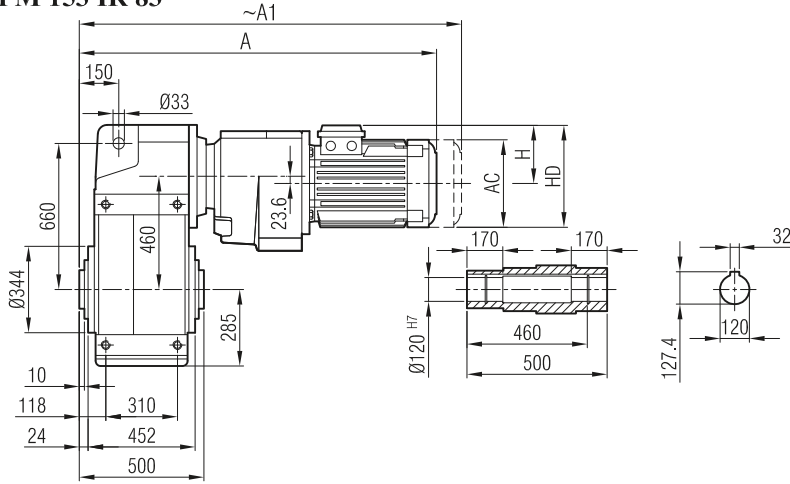

	80	90 S	90 L	100	112
A	919	947	972	1012	1034
A <sub>1</sub>	988	1013	1038	1090	1117
H	118	126	126	134	145
HD	198	216	216	234	257
AC	156	176	176	194	218

**YP 152 İR 82 / YP 152 İR 83**  
**YP 153 İR 82 / YP 153 İR 83**

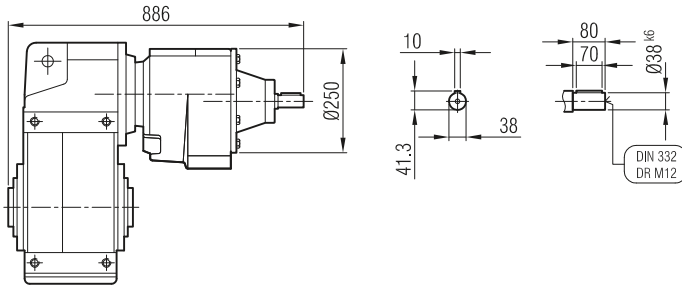

**"A<sub>1</sub>" Ölçüsü Frenli Motorlar içindir.**  
Dimension "A<sub>1</sub>" is for motors with brake.  
Le dimensions "A<sub>1</sub>" correspondent aux moteurs équipés de freins.

**YPPM 152 İR 83**  
**YPPM 153 İR 83**

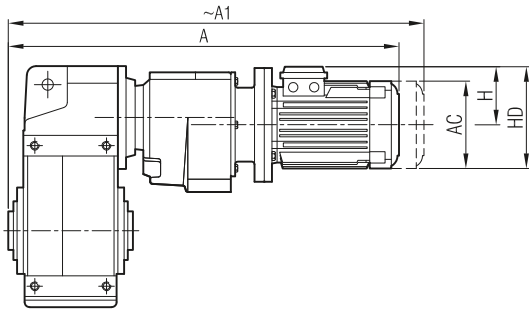

	80/B5	90 S/B5	90 L/B5	100/B5	112/B5
A	1007	1022	1047	1087	1107
A <sub>1</sub>	1076	1088	1113	1165	1190
H	118	126	126	134	145
HD	198	216	216	234	257
AC	156	176	176	194	218

**"A<sub>1</sub>" Ölçüsü Frenli Motorlar içindir.**  
Dimension "A<sub>1</sub>" is for motors with brake.  
Le dimensions "A<sub>1</sub>" correspondent aux moteurs équipés de freins.

**YPP 152 İR 83**  
**YPP 153 İR 83**

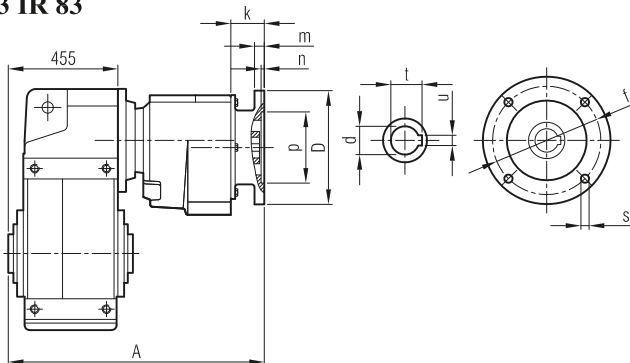

	A	Øp	Øf	ØD	s	k	m	n	Ød	t	u
80/B5	763	130	165	200	M10	67	12	5	19	21.8	6
90/B5	763	130	165	200	M10	67	12	5	24	27.3	8
100/B5	771	180	215	250	M12	71.5	14	5	28	31.3	8
112/B5	771	180	215	250	M12	71.5	14	5	28	31.3	8



**YPM / YP  
YPPM / YPP**

**... -SL**

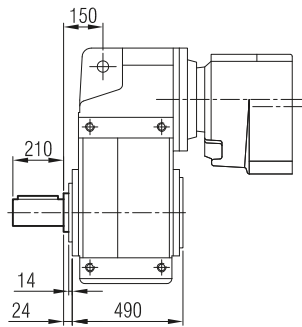

**... -H**

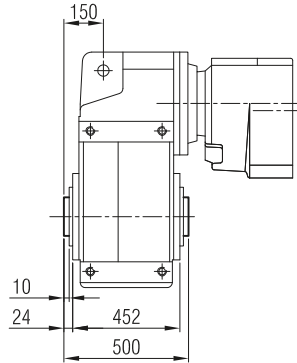

**... -SDL**

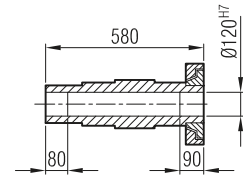
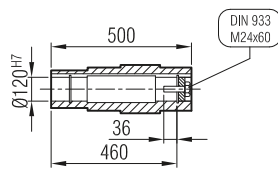
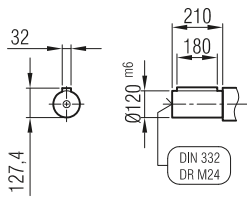
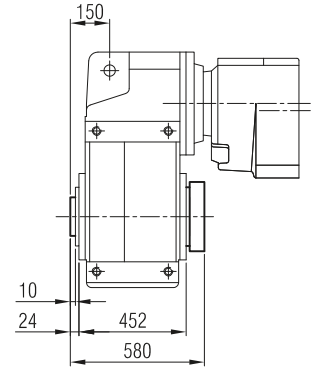

**YPFM / YPF  
YPFPM / YFPF**

**... -FL -SL**

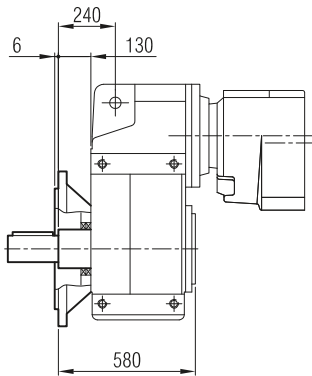

**... -FL**

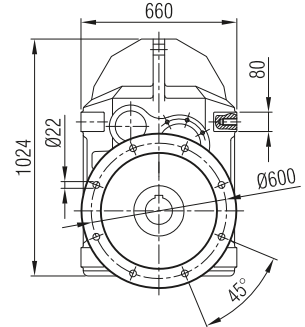
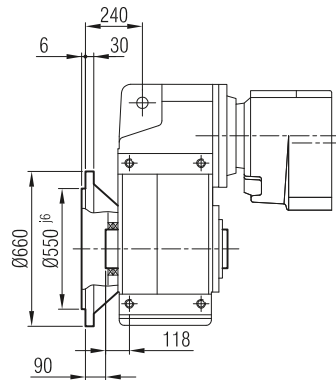

**-TL**

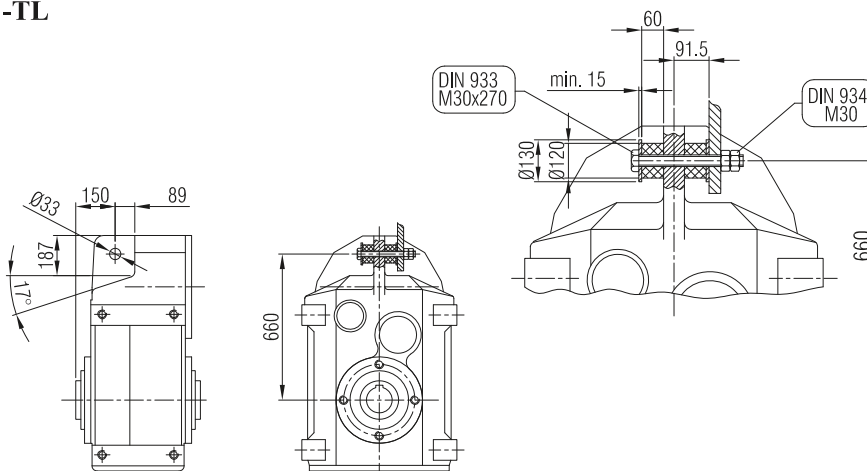

**Klemens Pozisyonları**  
Terminal Box Positions  
Klemenskasten Positionen

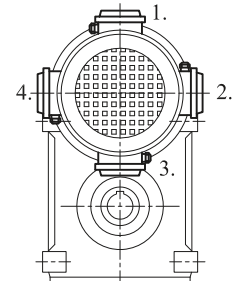



**YPM 153 İR 92**  
**YPM 153 İR 93**

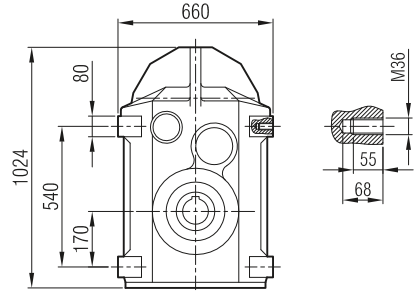
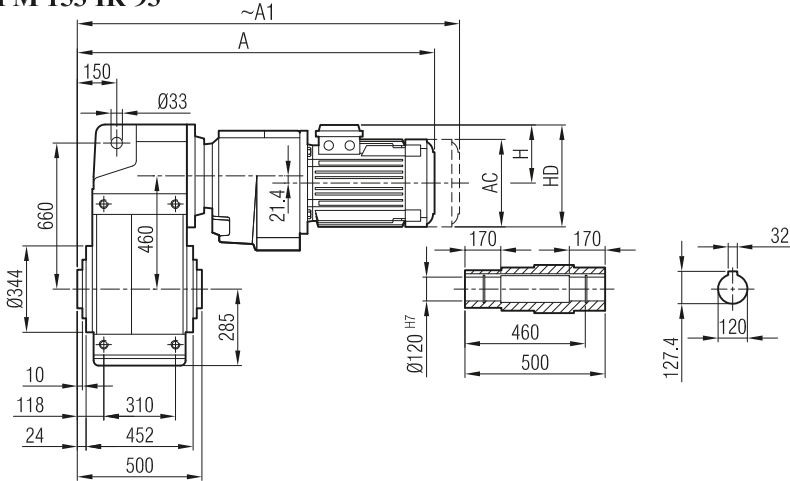

	100	112	132 S	132 M	160 M	160 L
A	1052	1075	1127	1165	1255	1299
A <sub>1</sub>	1130	1158	1227	1265	1370	1414
H	134	145	168	168	220	220
HD	234	257	300	300	380	380
AC	194	218	257	257	310	310

**YP 153 İR 92**  
**YP 153 İR 93**

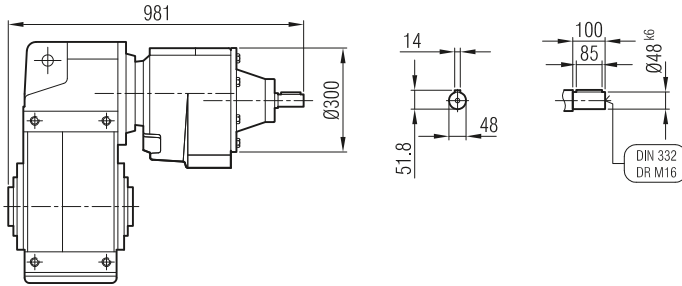

**"A<sub>1</sub>" Ölçüsü Frenli Motorlar içindir.**  
Dimension "A<sub>1</sub>" is for motors with brake.  
*Le dimensions "A<sub>1</sub>" correspondent aux moteurs équipés de freins.*

**YPPM 153 İR 92**  
**YPPM 153 İR 93**

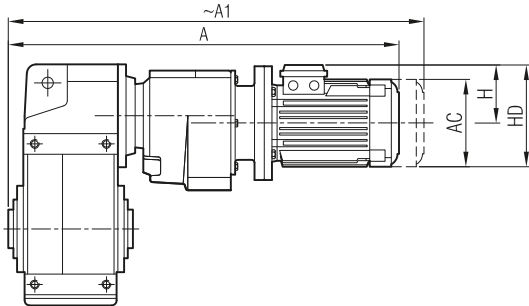

	90 S/B5	90 L/B5	100/B5	112/B5	132 S/B5	132 M/B5	160 M/B5	160 L/B5
A	1055	1080	1121	1141	1222	1260	1348	1392
A <sub>1</sub>	1121	1146	1199	1224	1322	1360	1463	1507
H	126	126	134	145	168	168	220	220
HD	216	216	234	257	300	300	380	380
AC	176	176	194	218	257	257	310	310

**"A<sub>1</sub>" Ölçüsü Frenli Motorlar içindir.**  
Dimension "A<sub>1</sub>" is for motors with brake.  
*Le dimensions "A<sub>1</sub>" correspond aux moteurs équipés de freins.*

**YPP 153 İR 92**  
**YPP 153 İR 93**

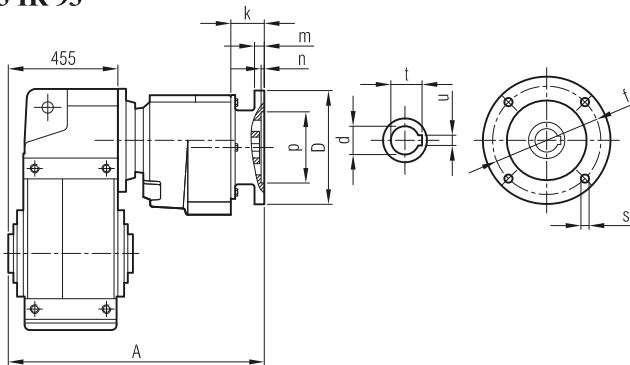

	A	Øp	Øf	ØD	s	k	m	n	Ød	t	u
90/B5	796	130	165	200	M10	49	12	5	24	27.3	8
100/B5	805	180	215	250	M12	58	14	5	28	31.3	8
112/B5	805	180	215	250	M12	58	14	5	28	31.3	8
132/B5	842	230	265	300	M12	95	17	6	38	41.3	10
160/B5	858	250	300	350	M14	111	18	6.5	42	45.3	12



**YPM / YP  
YPPM / YPP**

**... -SL**

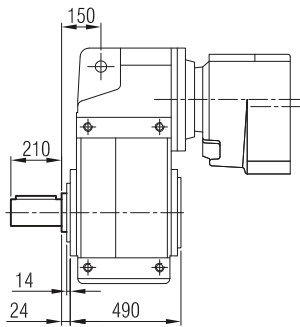

**... -H**

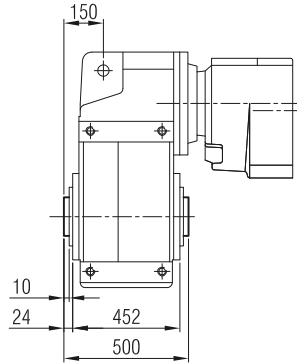

**... -SDL**

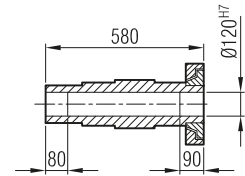
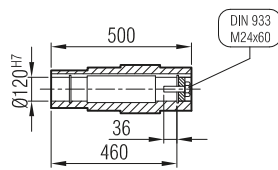
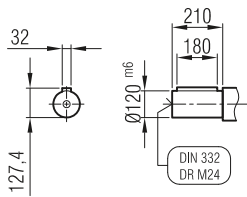
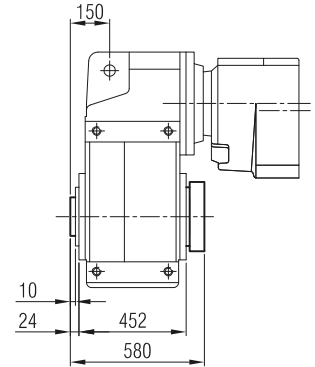

**YPFM / YPF  
YPFPM / YFPF**

**... -FL -SL**

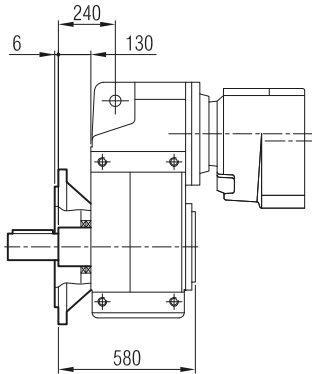

**... -FL**

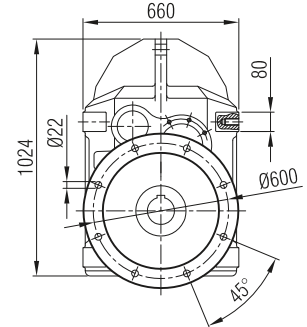
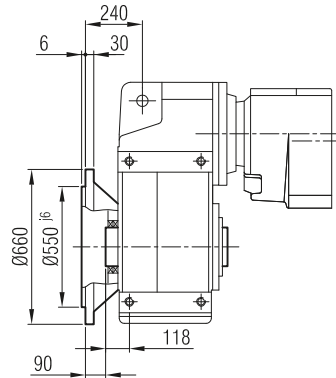

**-TL**

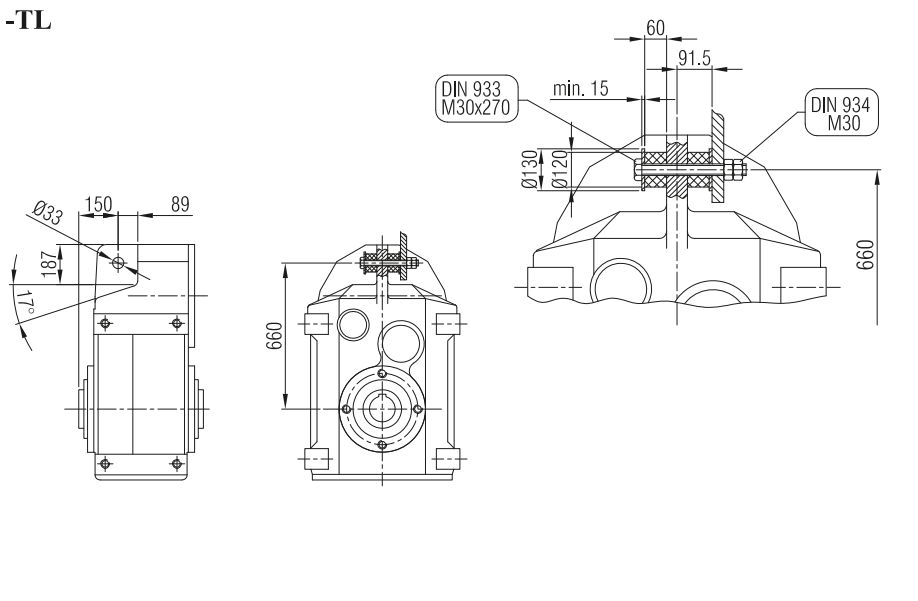

**Klemens Pozisyonları**  
Terminal Box Positions  
Klemenskasten Positionen

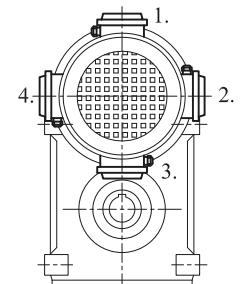

**Paralel milli ekstruder redüktörler**

Parallel shaft gear units with extruder / Réducteurs à arbres parallèles pour extrudeuse

Kod	Tanımlama	Type designation	Spécifications des types
YPE...	Giriş milli - ekstruder kovanlı	Input shaft - foot mounted -	Avec moteur - a pattes
YPEM...	Motorlu - ekstruder kovanlı	With motor - foot mounted -	Arbre d'entre - a pattes
YPEP...	IEC giriş flanşlı - ekstruder kovanlı	IEC B14 input flange - foot mounted -	IEC B14 Avec bride d'entrée - a pattes
YPEPM...	IEC giriş flanşlı motorlu - ekstruder kovanlı	IEC B14 input flange - flange mounted -	IEC B14 Avec bride d'entrée - bride de sortie

**Çıkış Opsiyonları**

Output Option / Options de sortie

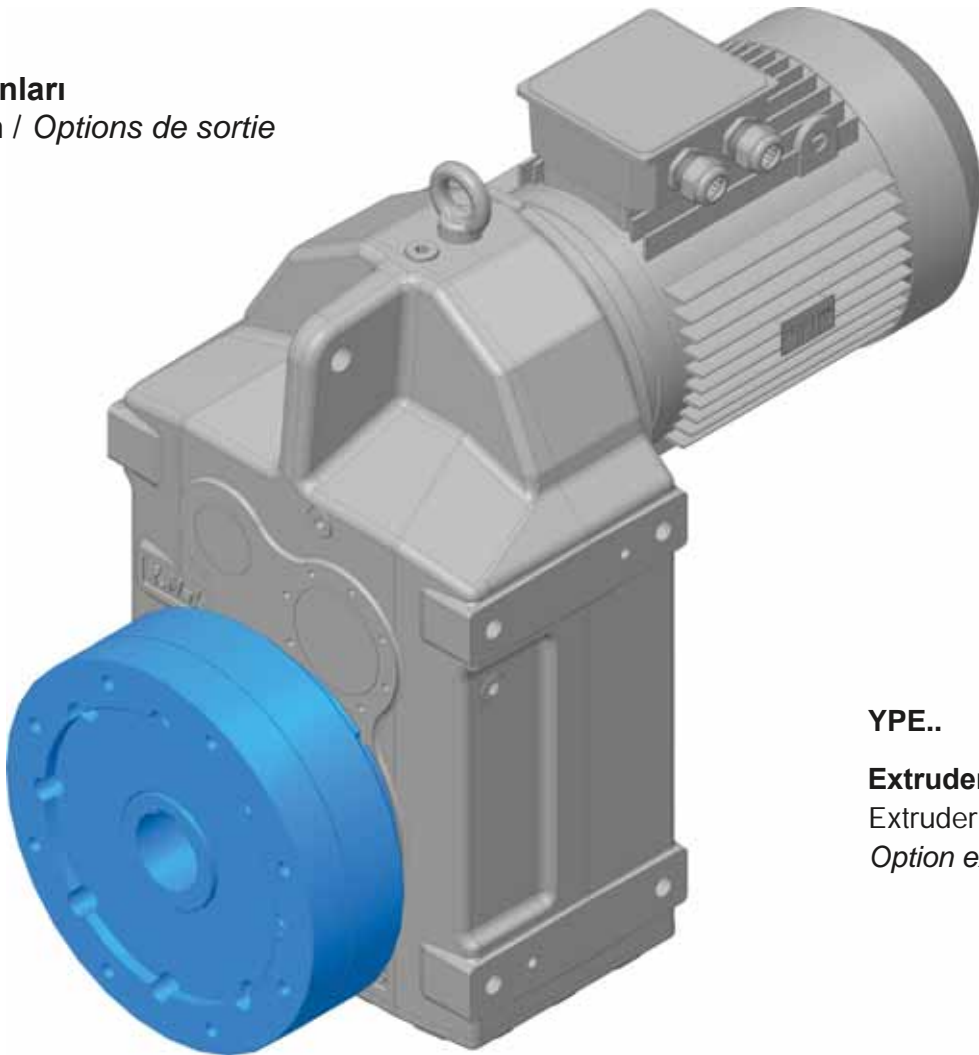
**YPE..****Extruder kovanlı**  
Extruder shaft  
Option extrudeuse



**YPEM**

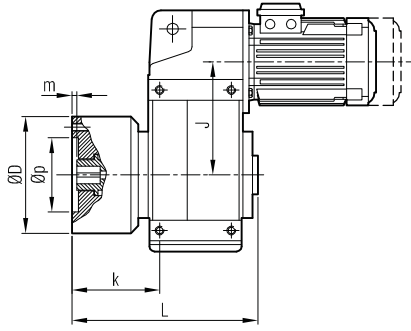

**YPEPM**

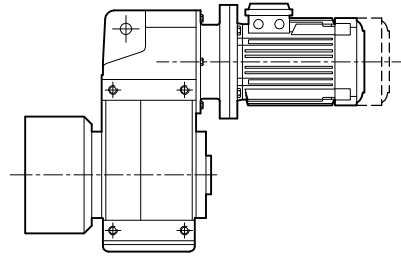

**YPE**

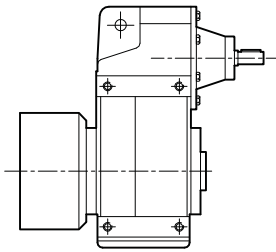

**YPEP**

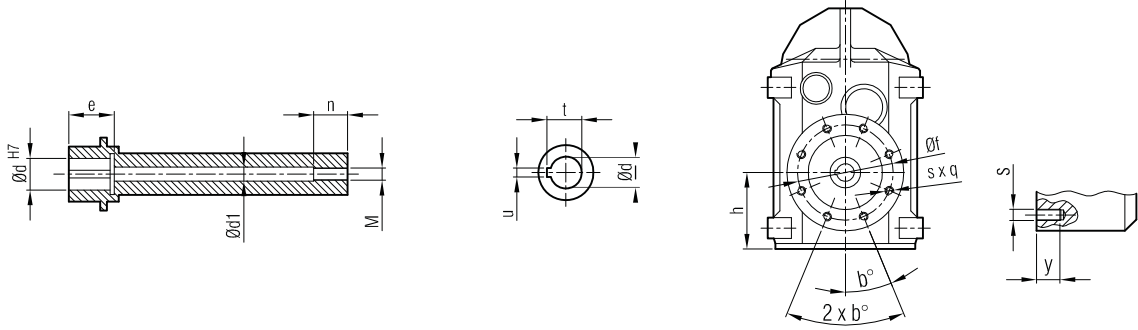
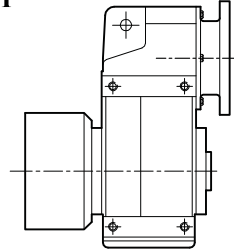

**q: Adet / Quantity / quantité**

	Øp	Øf	ØD	m	s	y	q	b°	Ød	Ød1	e	u	t	M	n	k	L	J	h
YPE... 53-52	95	115	140	8	M8	39	4	45°	24	12	56	8	27.3	M10	20	99	194.5	155	79
YPE... 63-62	110	130	160	8	M8	39	4	45°	28	14	63	8	31.3	M12	24	119	238	131	88
YPE... 73-72	130	165	200	8	M10	31	8	22.5°	35	20	58	10	38.3	M18	36	131.5	266	159	110
YPE... 83-82	130	165	200	10	M12	37	8	22.5°	40	20	58	12	43.3	M18	36	147	320	196	129
YPE... 93-92	180	215	250	10	M14	40	8	22.5°	50	26	72	14	53.8	M24	48	138	342	241	149
YPE... 103-102	230	265	300	10	M14	50	8	22.5°	60	26	93	18	64.4	M24	48	169	426	294	178
YPE... 123-122	300	350	400	10	M16	52	8	22.5°	80	26	115	22	85.4	M24	48	198.5	489	333	204
YPE... 143-142	250	300	350	10	M20	44	8	22.5°	100	32	125	28	106.4	M30	60	247	583	391	242
YPE... 153-152	350	400	450	10	M24	57	10	18°	110	32	130	28	116.4	M30	60	258	640	460	285

**Redüktör gövde ölçüleri için standart ölçü sayfasına bakınız.**

For gearbox housing dimensions please refer to the standart dimension pages.

La taille standard pour le boîtier de réducteur, reportez-vous à la taille de la page.

## YP Serisi Yedek Para Listeleri

---

General Parts List  
*Liste des pices dtaches*



**Notlar**  
Notes



**TİP / TYPE / TYP**

**YPM - YPPM - YP - YPP**

**YPFM - YPPFM - YPF - YPPF**

} 52-62-72-82-92-102-122-142-152

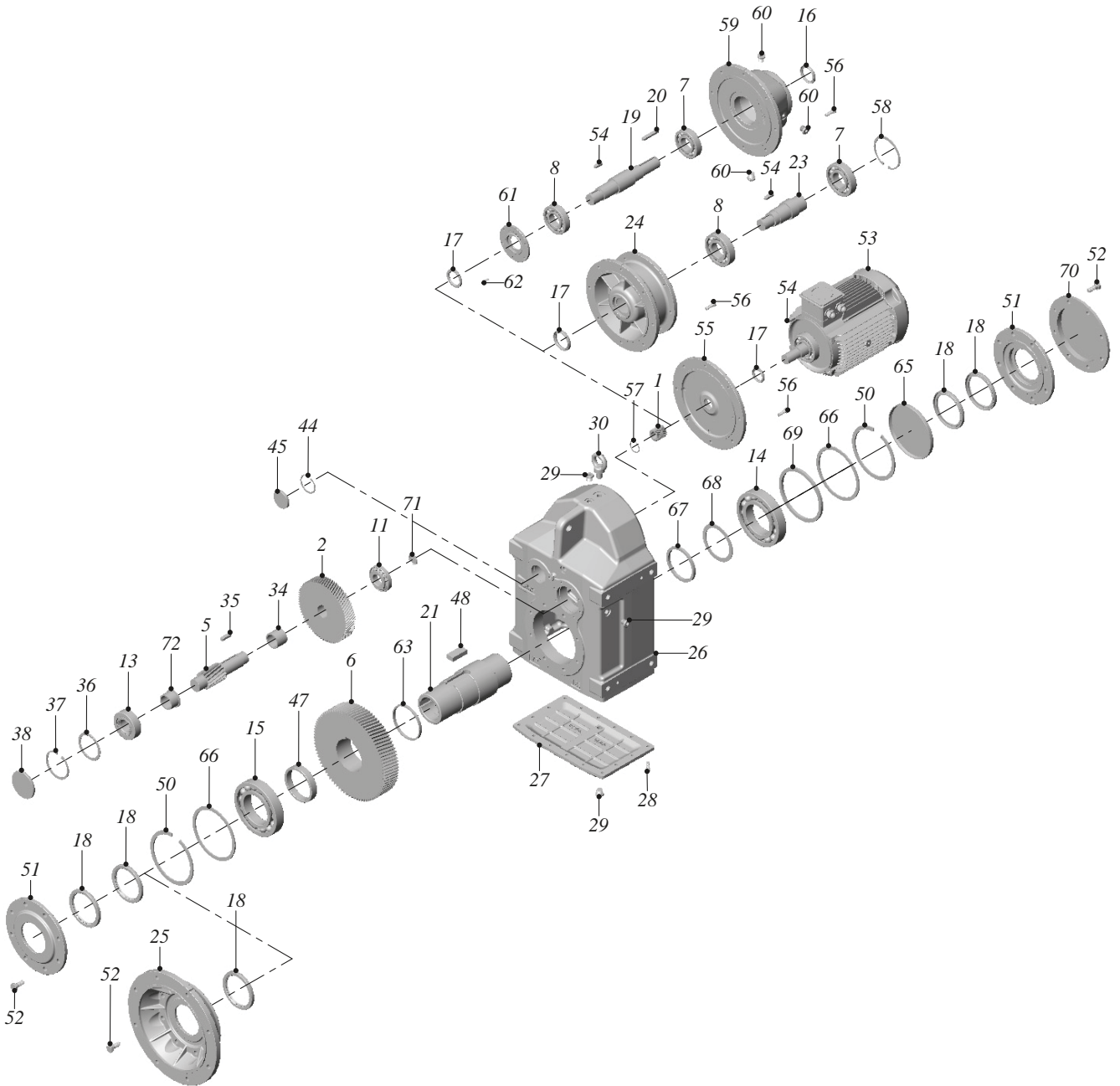

**TİP / TYPE****YPM / YPPM / YP / YPP****YPFM / YPFPM / YPF / YFPF**

} 52-62-72-82-92-102-122

1 - Dişli Z1	1 - Gear Z1	1 - Pignon Z1
2 - Dişli Z2	2 - Gear Z2	2 - Pignon Z2
5 - Milli Dişli Z3	5 - Gear Z3	5 - Pignon Z3
6 - Dişli Z4	6 - Gear Z4	6 - Pignon Z4
11 - Rulman	11 - Bearing	11 - Roulement
13 - Rulman	13 - Bearing	13 - Roulement
14 - Rulman	14 - Bearing	14 - Roulement
15 - Rulman	15 - Bearing	15 - Roulement
16 - Keçe	16 - Seal	16 - Joint
17 - Keçe	17 - Seal	17 - Joint
18 - Keçe	18 - Seal	18 - Joint
19 - Giriş Mili	19 - Input Shaft	19 - Arbre d'entrée
20 - Kama	20 - Key	20 - Clavette
21 - Kovan	21 - Hollow Shaft	21 - Arbre creux
23 - Ara Bağlantı Mili	23 - Connection Shaft	23 - Arbre connecteur
24 - Pam Flanş (IEC)	24 - IEC Flange	24 - Bride IEC
25 - Flanş	25 - Flange	25 - Bride
26 - Gövde	26 - Gear Case	26 - Carter
27 - Kapak	27 - Cover	27 - Couvercle
28 - Cıvata	28 - Bolt	28 - Vis
29 - Yağ Tapası	29 - Oil Plug	29 - Bouchon d'huile
30 - Taşıma Kancası	30 - Lifting Eye Bolt	30 - Anneau de levage
34 - Burç	34 - Spacer	34 - Anneau d'espacement
35 - Kama	35 - Key	35 - Clavette
36 - Pul	36 - Washer	36 - Joint
37 - Segman	37 - Circlip	37 - Circlip
38 - Tapa	38 - Locking Cover	38 - Bouchon
44 - Segman	44 - Circlip	44 - Circlip
45 - Tapa	45 - Locking Cover	45 - Bouchon
47 - Burç	47 - Spacer	47 - Anneau d'espacement
48 - Kama	48 - Key	48 - Clavette
50 - Segman	50 - Circlip	50 - Circlip
51 - Keçe Kapağı	51 - Seal Cover	51 - Joint
52 - Cıvata	52 - Bolt	52 - Vis
53 - Motor	53 - Electric Motor	53 - Moteur électrique
54 - Kama	54 - Key	54 - Clavette
55 - Motor Bağlantı Kapağı	55 - Motor Mounting Adapter	55 - Bride moteur
56 - Cıvata	56 - Bolt	56 - Vis
57 - Segman	57 - Circlip	57 - Circlip
58 - Segman	58 - Circlip	58 - Circlip
59 - Motorsuz Kapak	59 - Input cover	59 - Bride d'entrée
60 - Yağ Tapası	60 - Oil Plug	60 - Bouchon d'huile
61 - Keçe Kapağı	61 - Seal Cover	61 - Joint
62 - Cıvata	62 - Bolt	62 - Vis
63 - Burç	63 - Spacer	63 - Anneau d'espacement
65 - Tapa	65 - Locking Cover	65 - Bouchon
66 - Pul	66 - Washer	66 - Joint
67 - Burç	67 - Spacer	67 - Anneau d'espacement
68 - Pul	68 - Washer	68 - Joint
69 - Burç	69 - Spacer	69 - Anneau d'espacement
70 - Toz Kapağı	70 - Hood Cover	70 - Couvercle
71 - Tapa	71 - Locking Cover	71 - Bouchon
72 - Burç	72 - Spacer	72 - Anneau d'espacement

**TİP / TYPE / TYP****YPM - YPPM - YP - YPP****YPFM - YPPFM - YPF - YPPF**

} 53-63-73-83-93-103-123-143-153

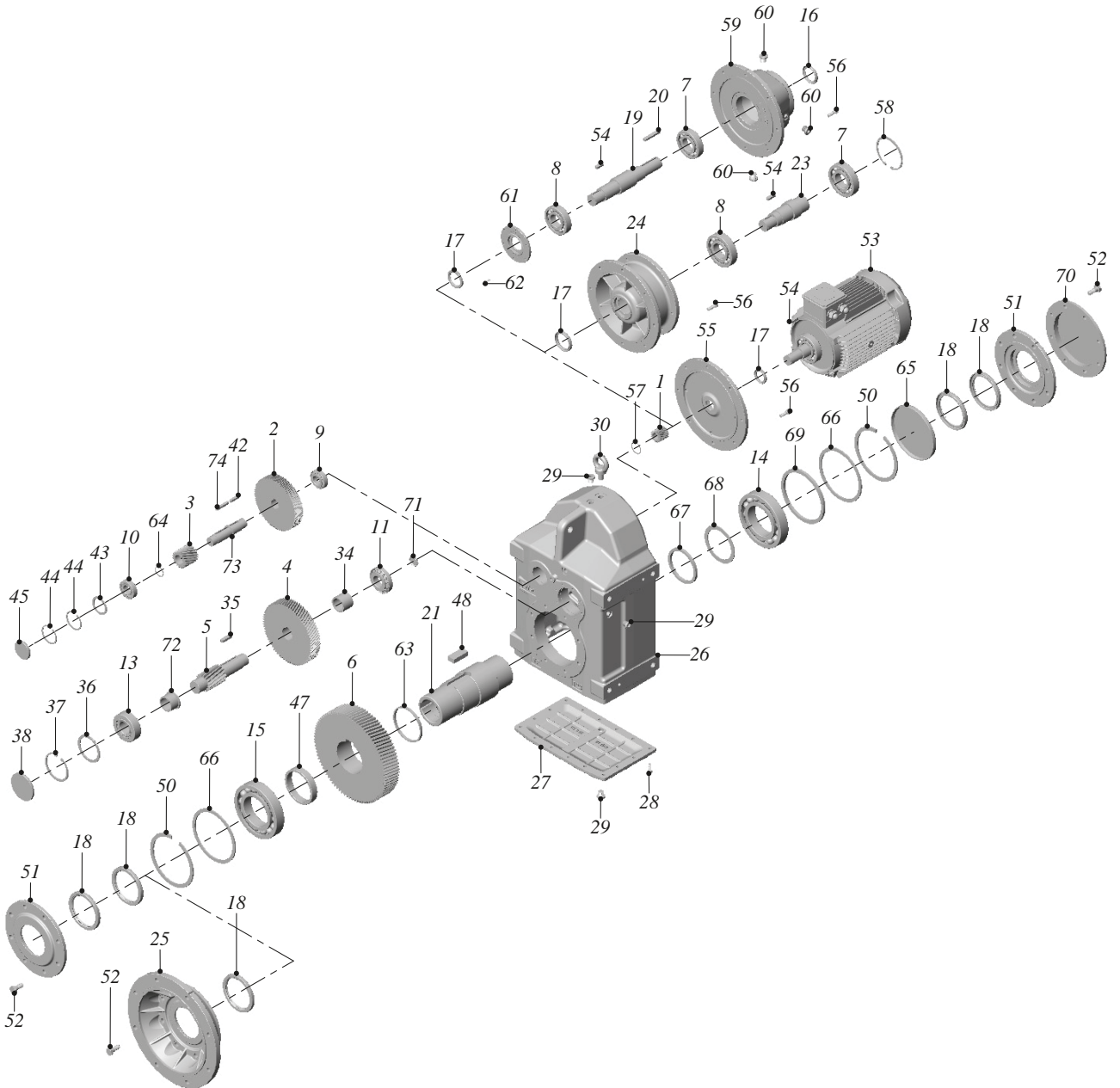

**TİP / TYPE****YPM / YPPM / YP / YPP****YPFM / YPFPM / YPF / YPFM**

} 53-63-73-83-93-103-123

1 - Dişli Z1	1 - Gear Z1	1 - Pignon Z1
2 - Dişli Z2	2 - Gear Z2	2 - Pignon Z2
3 - Milli Dişli Z3	3 - Gear Z3	3 - Pignon Z3
4 - Dişli Z4	4 - Gear Z4	4 - Pignon Z4
5 - Milli Dişli Z5	5 - Gear Z5	5 - Pignon Z5
6 - Dişli Z6	6 - Gear Z6	6 - Pignon Z6
7 - Rulman	7 - Bearing	7 - Roulement
8 - Rulman	8 - Bearing	8 - Roulement
9 - Rulman	9 - Bearing	9 - Roulement
10 - Rulman	10 - Bearing	10 - Roulement
11 - Rulman	11 - Bearing	11 - Roulement
13 - Rulman	13 - Bearing	13 - Roulement
14 - Rulman	14 - Bearing	14 - Roulement
15 - Rulman	15 - Bearing	15 - Roulement
16 - Keçe	16 - Seal	16 - Joint
17 - Keçe	17 - Seal	17 - Joint
18 - Keçe	18 - Seal	18 - Joint
19 - Giriş Mili	19 - Input Shaft	19 - Arbre d'entrée
20 - Kama	20 - Key	20 - Clavette
21 - Kovan	21 - Hollow Shaft	21 - Arbre creux
23 - Ara Bağlantı Mili	23 - Connection Shaft	23 - Arbre connecteur
24 - Pam Flanş (IEC)	24 - IEC Flange	24 - Bride IEC
25 - Flanş	25 - Flange	25 - Bride
26 - Gövde	26 - Gear Case	26 - Carter
27 - Kapak	27 - Cover	27 - Couvercle
28 - Cıvata	28 - Bolt	28 - Vis
29 - Yağ Tapası	29 - Oil Plug	29 - Bouchon d'huile
30 - Taşıma Kancası	30 - Lifting Eye Bolt	30 - Anneau de levage
34 - Burç	34 - Spacer	34 - Anneau d'espacement
35 - Kama	35 - Key	35 - Clavette
36 - Pul	36 - Washer	36 - Joint
37 - Segman	37 - Circlip	37 - Circlip
38 - Tapa	38 - Locking Cover	38 - Bouchon
42 - Kama	42 - Key	42 - Clavette
43 - Pul	43 - Washer	43 - Joint
44 - Segman	44 - Circlip	44 - Circlip
45 - Tapa	45 - Locking Cover	45 - Bouchon
47 - Burç	47 - Spacer	47 - Anneau d'espacement
48 - Kama	48 - Key	48 - Clavette
50 - Segman	50 - Circlip	50 - Circlip
51 - Keçe Kapağı	51 - Seal Cover	51 - Joint
52 - Cıvata	52 - Bolt	52 - Vis
53 - Motor	53 - Electric Motor	53 - Moteur électrique
54 - Kama	54 - Key	54 - Clavette
55 - Motor Bağlantı Kapağı	55 - Motor Mounting Adapter	55 - Bride moteur
56 - Cıvata	56 - Bolt	56 - Vis
57 - Segman	57 - Circlip	57 - Circlip
58 - Segman	58 - Circlip	58 - Circlip
59 - Motorsuz Kapak	59 - Input cover	59 - Bride d'entrée
60 - Yağ Tapası	60 - Oil Plug	60 - Bouchon d'huile
61 - Keçe Kapağı	61 - Seal Cover	61 - Joint
62 - Cıvata	62 - Bolt	62 - Vis
63 - Burç	63 - Spacer	63 - Anneau d'espacement
64 - Segman	64 - Circlip	64 - Circlip
65 - Tapa	65 - Locking Cover	65 - Bouchon
66 - Pul	66 - Washer	66 - Joint
67 - Burç	67 - Spacer	67 - Anneau d'espacement
68 - Pul	68 - Washer	68 - Joint
69 - Burç	69 - Spacer	69 - Anneau d'espacement
70 - Toz Kapağı	70 - Hood Cover	70 - Couvercle
71 - Tapa	71 - Locking Cover	71 - Bouchon
72 - Burç	72 - Spacer	72 - Anneau d'espacement
73 - Dişli Mili	73 - Gear Shaft	73 - Arbre a pignons
74 - Kama	74 - Key	74 - Clavette



**TİP / TYPE**

**YPM - YPPM - YP - YPP**

**YPFM - YPPFM - YPF - YPPF**

} 54-64-74-84-94-104-124-144-154

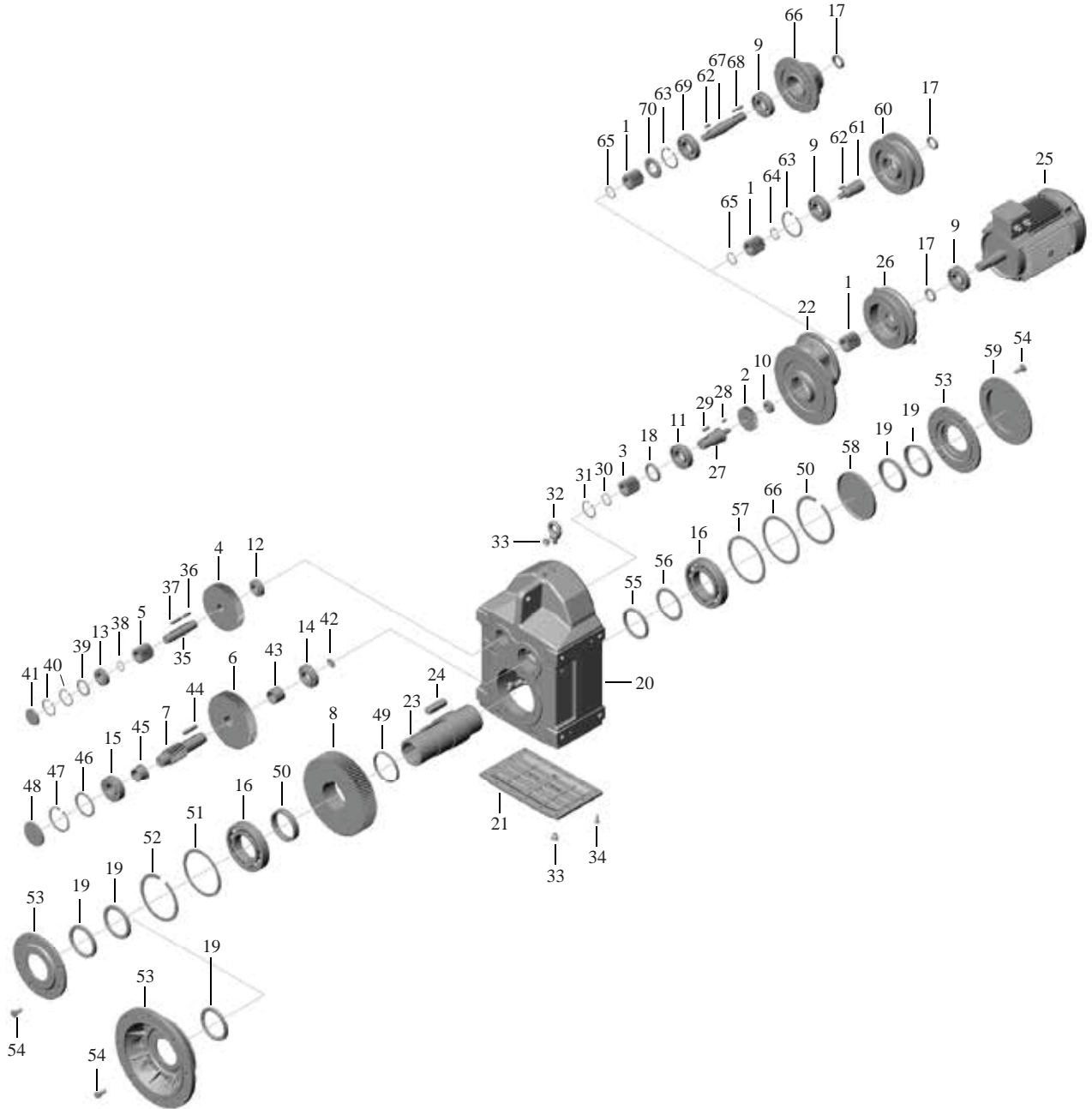

**TİP / TYPE****YPM / YPPM / YP / YPP****YPFM / YPFPM / YPF / YPFM**

} 74-84-94-104-124-144-154

1 - Dişli Z1	1 - Gear Z1	1 - Pignon Z1
2 - Dişli Z2	2 - Gear Z2	2 - Pignon Z2
3 - Dişli Z3	3 - Gear Z3	3 - Pignon Z3
4 - Dişli Z4	4 - Gear Z4	4 - Pignon Z4
5 - Milli Dişli Z5	5 - Gear Z5	5 - Pignon Z5
6 - Dişli Z6	6 - Gear Z6	6 - Pignon Z6
7 - Milli Dişli Z7	7 - Gear Z7	7 - Pignon Z7
8 - Dişli Z8	8 - Gear Z8	8 - Pignon Z8
9 - Rulman	9 - Bearing	9 - Roulement
10 - Rulman	10 - Bearing	10 - Roulement
11 - Rulman	11 - Bearing	11 - Roulement
12 - Rulman	12 - Bearing	12 - Roulement
13 - Rulman	13 - Bearing	13 - Roulement
14 - Rulman	14 - Bearing	14 - Roulement
15 - Rulman	15 - Bearing	15 - Roulement
16 - Rulman	16 - Bearing	16 - Roulement
17 - Keçe	17 - Seal	17 - Joint
18 - Keçe	18 - Seal	18 - Joint
19 - Keçe	19 - Seal	19 - Joint
20 - Gövde	20 - Gear Case	20 - Carter
21 - Kapak	21 - Cover	21 - Couvercle
22 - V Gövde	22 - Gear Case V	22 - Carter V
23 - Kovan	23 - Hollow Shalt	23 - Arbre creux
24 - Kama	24 - Key	24 - Clavette
25 - Motor	25 - Electric Motor	25 - Moteur électrique
26 - Motor Bağlantı Kapağı	26 - Motor Mounting Adapter	26 - Bride moteur
27 - Ara Bağlantı Mili	27 - Connection Shaft	27 - Arbre connecteur
28 - Kama	28 - Key	28 - Clavette
29 - Kama	29 - Key	29 - Clavette
30 - Segman	30 - Circlip	30 - Circlip
31 - Segman	31 - Circlip	31 - Circlip
32 - Taşıma Kancası	32 - Lifting Eye Bolt	32 - Anneau de levage
33 - Yağ Tapası	33 - Oil Plug	33 - Bouchon d'huile
34 - Cıvata	34 - Bolt	34 - Vis
35 - Dişli Mili	35 - Gear Shaft	35 - Arbre a pignons
36 - Kama	36 - Key	36 - Clavette
37 - Kama	37 - Key	37 - Clavette
38 - Segman	38 - Circlip	38 - Circlip
39 - Pul	39 - Washer	39 - Joint
40 - Segman	40 - Circlip	40 - Circlip
41 - Tapa	41 - Locking Cover	41 - Bouchon
42 - Tapa	42 - Locking Cover	42 - Bouchon
43 - Burç	43 - Spacer	43 - Anneau d'espacement
44 - Kama	44 - Key	44 - Clavette
45 - Burç	45 - Spacer	45 - Anneau d'espacement
46 - Pul	46 - Washer	46 - Joint
47 - Segman	47 - Circlip	47 - Circlip
48 - Tapa	48 - Locking Cover	48 - Bouchon
49 - Burç	49 - Spacer	49 - Anneau d'espacement
50 - Burç	50 - Spacer	50 - Anneau d'espacement
51 - Pul	51 - Washer	51 - Joint
52 - Segman	52 - Circlip	52 - Circlip
53 - Keçe Kapağı / Flanş	53 - Seal Cover / Flange	53 - Joint / Bride
54 - Cıvata	54 - Bolt	54 - Vis
55 - Burç	55 - Spacer	55 - Anneau d'espacement
56 - Pul	56 - Washer	56 - Joint
57 - Pul	57 - Washer	57 - Joint
58 - Tapa	58 - Locking Cover	58 - Bouchon
59 - Toz Kapağı	59 - Hood Cover	59 - Couvercle
60 - Pam Flanş (IEC)	60 - IEC Flange	60 - Bride IEC
61 - Ara Bağlantı Mili	61 - Connection Shaft	61 - Arbre connecteur
62 - Kama	62 - Key	62 - Clavette
63 - Segman	63 - Circlip	63 - Circlip
64 - Segman	64 - Circlip	64 - Circlip
65 - Segman	65 - Circlip	65 - Circlip
66 - Motorsuz Kapak	66 - Input cover	66 - Bride d'entrée
67 - Giriş Mili	67 - Input shaft	67 - Arbre d'entrée
68 - Kama	68 - Key	68 - Clavette
69 - Rulman	69 - Bearing	69 - Roulement
70 - Keçe	70 - Seal	70 - Joint

**Notlar**  
Notes



**Notlar**  
Notes



REDÜKTÖR & VARYATÖR SAN. VE TİC. A.Ş.

**Fabrika - Merkez Satış**

Şeyhli Sanayi Caddesi No:1 Pendik / İSTANBUL - TÜRKİYE  
Tel. +90 216 378 03 26 (Pbx) - Fax. +90 216 378 06 86

**Satış Ofisi**

Demirkapı Mah. Keresteciler Sit. Rıza Uzun Sk. No:5 Topçular / İSTANBUL - TÜRKİYE  
Tel. +90 212 567 87 32/33 - Fax. +90 212 612 61 17

imak@imakreduktor.com

[www.imakreduktor.com](http://www.imakreduktor.com)